

# NAVIGATION SYSTEM FOR INDOOR MOBILE ROBOTS BASED ON RFID TAGS

Toshifumi Tsukiyama and Atsushi Suzuki

*School of Information Environment, Tokyo Denki University, Inzai, Chiba, Japan*

**Keywords:** Mobile Robot, Navigation, RFID Tag, IC Memory, Landmark, Topological Map.

**Abstract:** A new navigation method is described for an indoor mobile robot. The robot system is composed of a Radio Frequency Identification (RFID) tag sensor and a commercial three-wheel mobile platform with ultrasonic rangefinders. The RFID tags are used as landmarks for navigation and the topological relation map which shows the connection of scattered tags through the environment is used as course instructions to a goal. The robot automatically follows paths using the ultrasonic rangefinders until a tag is found and then refers the next movement to the topological map for a decision. Our proposed technique would be useful for real-world robotic applications such as intelligent navigation for motorized wheelchairs.

## 1 INTRODUCTION

This paper describes a navigation system for mobile robots which are assumed to move autonomously to a given goal in man-made environments such as hallways in a building. A key function of the navigation system is to choose a direction to a goal at a particular place such the intersection of two hallways in a building. The navigation system requires a mechanism for recognizing such particular places in the building and locating them on a world map that gives course directions to a goal.

Two common approaches to robot navigation are metric-based and landmark-based navigation (Murphy, 2000). Metric-based navigation relies on metric maps of the environment, resulting in navigation plans such as move forward five meters, turn right ninety degrees and move forward another eight meters. For position-sensing schemes, this approach relies on dead-reckoning based on information about the motion of the robot derived from the wheel encoders, or absolute position estimation using the global positioning system (GPS) (Hofmann-Wellenof, 2003). These metric data are, however, likely to be corrupted by sensor noise and this navigation method is vulnerable to inaccuracies in position estimates.

To avoid reliance on error-prone metric data, an alternative approach is landmark-based navigation. Landmark-based navigation relies on topological maps whose nodes correspond to landmarks (locally distinctive places) such as corridor junctions or doors. Map edges indicate how the landmarks connect and how the robot should navigate between them. A typical landmark-based navigation plan might be to move forward to the junction, turn into the corridor on the right, move to its end, and stop. This may involve a complete absence of metric data and then the method does not depend on geometric accuracy (Kawamura, 2002). It has apparent analogies with human spatial perception, so it is easy to make a map of the environment. In addition, topological representations avoid the potentially massive storage costs associated with metric representations.

One problem to be solved in this method is to decide what are suitable for landmarks in the environment. Landmarks should be a distinctive one and easy to recognize without special costs. In a building intersections, corners and doors are very important places for navigation and they could be a landmark. However, they are often repetitively similar and suffer from problem of occasionally sensors not being able to distinguish between similar landmarks, such as different doors of the same size. This can lead to

both inefficiency and mistakes. Although such landmarks with an artificial sign could be reliable and useful, painted marks on walls would require special image processing to extract them from the scene. This would entail a complicated and costly process.

Therefore, we propose a method using Radio Frequency Identification (RFID) tags as a sign. The RFID tags are a passive, non-contact, read-only memory system based on electromagnetic wave and can store a unique number for identification of the location. The tags allow the acquisition of location information at remarkable speeds without any distance information and the accurate control of robot positions for sensing landmarks. Micro-processors with a wireless modem may be possible to give location information as a landmark (Fujii, 1997). Although they have the ability to handle data processing, they need an on-board power supply like a battery. Landmarks should be embedded in the environment and offer a virtually unlimited operational lifetime. The passive RFID tags operate without a separate external power source and obtain operating power generated from the reader. The tags are consequently much lighter, thinner and less expensive than the active devices with a microprocessor. The RFID tags can give enough location information to achieve the robustness and efficiency of navigation.

## 2 RFID TAGS AS LANDMARKS

Figure 1 shows an RFID tags and the antenna box of the RFID tag sensor system on a mobile robot. The RFID tag (shielded in a 12 cm square plastic plate) is an IC memory (115 Bytes) with a built-in antenna, which is pasted on walls at particular places in a building. Each IC memory has a unique ID number which can provide information on its location within the building. Figure 2 illustrates the way to get ID number in a tag through the RFID tag sensor system on the robot. The RFID tag sensor consists of an RF transceiver and an antenna. The RF transceiver illuminates an RFID tag with a short pulse of electromagnetic waves (2.45 GHz, 0.3 w). The tag receives the RF transmission, rectifies the signal to obtain DC power, reads its memory to get the ID number, and modulates the antenna backscatter in response to the interrogation. The RF transceiver obtains the ID number and reports it to the navigation system running on a Linux computer through an RS-232c serial port. Figure 3 illustrates the sensitivity map of the RFID tag sensor system. Since the induction area of a tag is 40 cm wide and 100 cm depth from the antenna the robot does not need precise positioning mechanisms

to locate and access the tags. The robot just passes by tags without the accurate control of position for sensing their numbers.



Figure 1: RFID tag pasted on a wall (white panel on right) and the antenna of a RFID tag sensor mounted on a mobile robot.

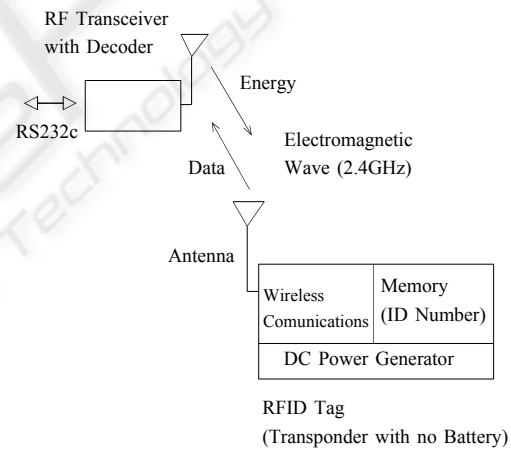

Figure 2: Architecture of the RFID tag sensor system.

## 3 MAP FOR NAVIGATION

Figure 4(a) shows an example of a floor plan in a building. The letters a, b, c, d, e, f, g, and h in the floor plan denote the intersections of two hallways, the junctions or near the door, which can be a particular place for a mobile robot. At these places the robot has to choose an action to reach a given goal; left-turn, right-turn, straight ahead, U-turn or stop if the place is the destination. The robot repeats one of these actions at every particular place. The particular places can be considered a sub-goal. Global tasks (i.e.

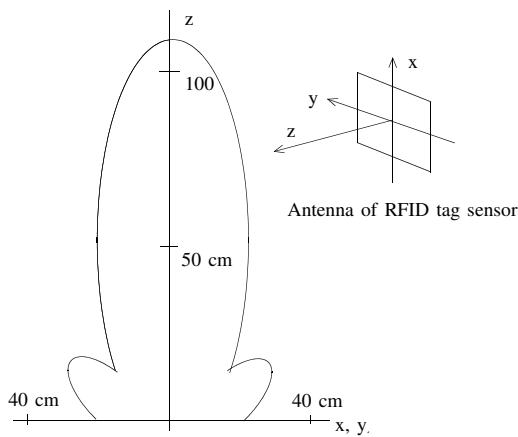

Figure 3: Sensitivity range of the RFID tag sensor system.

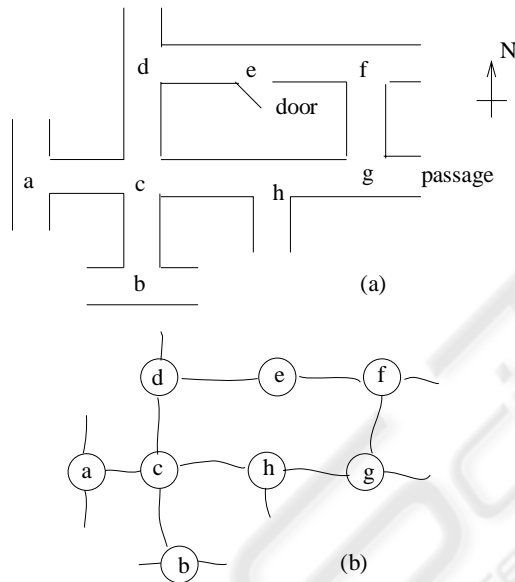
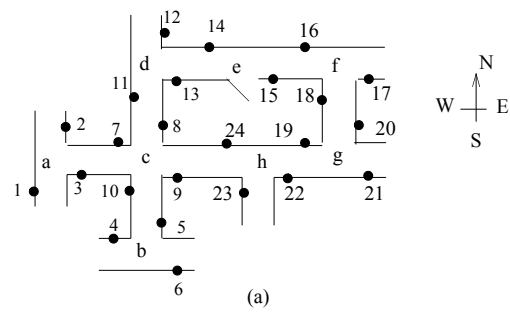

Figure 4: Example of a floor plan (a) and its topological map (b).

going to a distant goal) require a world map for deciding a sequence of sub-goals to a given goal. Figure 4(b) describes the topological relation of these particular places in the building. The nodes of the graph with a letter correspond to the particular places such as an intersection in the floor plan, respectively. An edge between two nodes denotes that a hallway exists and a robot can pass along it to the next particular place. Using graph search techniques you can generate a sequence of particular places to lead the robot to a given goal, if a starting node is given on the graph. The topological relation of particular places through hallways can be used as a world map.

To distinguish particular places in the building we



Node c			Node d		
Direction	Node	Tag ID	Direction	Node	Tag ID
N	d	8	N	?	12
E	h	9	E	e	13
S	b	10	S	c	11
W	a	7	W	--	--

(b)

Figure 5: Configuration of RFID tags for the floor plan (a) and examples of the data structure of a node (b).

use the RFID tags. The tags are pasted on the left side walls near the intersections of two hallways, the junctions or doors. Actually, it is very difficult to paste a tag precisely in a fixed position in a hallway or to measure its position. The role of tags is to give just information that the robot is coming upon an intersection and what the name of the intersection is. Figure 5(a) illustrates the configuration of the tags in the floor plan. The dots near particular places show the positions of RFID tags and the numbers are an ID number which the navigation system uses to identify upcoming intersections in the robot path. The scattered tags through hallways are used as a cue to decide the next action. In our scenario the robot moves along the left side of hallways finding tags and then the navigation system recognizes the robot's location on a world map based on the tag's ID number and decides the next movement of the robot toward a given goal.

In path planning the navigation system must decide a travel direction to the next sub-goal at an intersection. To do this the order of the adjacent edges which join at a node should be explicitly described in the world map. In other words this means to describe on the map which hallway is on the left or right side with respect to one hallway. One possible way is to draw up a list of hallways in the data structure of each node, maintaining the clockwise order of the hallways. However, this is likely to confuse the order when you trace the topological map from an entire floor plan. In our scenario robots pass through hallways in a building. They are usually intersected like

a cross. Therefore, we use compass points such as North (N), South (S), East(E), West (W) for a rule of the notation of directions. When you make a world map, first, you should assign the North direction on the floor plan for the reference bearing.

The data structure of a node include the list of adjacent nodes with a compass point and tag ID numbers which a robot will find coming to a particular place. Figure 5(b) illustrates examples of the data structure of a node of the graph. The mark “-” in the node d denotes there is no hallway in this direction, because the node d is a junction. The mark “?” means that a hallway exists but the name of an adjacent node is unknown at the moment. If a robot finds a tag with the ID number 9 in a hallway, for example, the navigation system searches all the node data of the graph for the tag number and then finds it is in the data structure of the node c. Consequently, the navigation system recognizes the robot is coming into the intersection c from the East side. Suppose that the next sub-goal is the junction d, the navigation system searches the node c for the next node direction. It finds that the node d is adjacent to the node c and the direction is the North. The robot is coming from the East side, turns to the right at the intersection and going out to the North side. Finally it will find another tag with the ID number 11. This process is repeated until the robot finds the goal.

We have developed an interactive system for making the database of map information from a floor plan. The system was built up on a Linux computer with the graphical tool kit GTK+ and the graphical user interface (GUI) is shown in Figure 6. The small window in the upper right corner displays the menus for editing. The main window is used to draw the topological connection of intersections and junctions the robot can pass through. First, the user assigns the North direction on the floor plan for the reference bearing. The mouse button is clicked on the screen and the mouse is dragged in one of the four directions (North, South, East or West), then two nodes with an edge is displayed and the data structures for the nodes as shown in Figure 5(b) are created in the system. After this the mouse button is clicked on one of the nodes and the mouse is dragged to extend the graph. Next, the user changes the editing mode to compile the data structure of a node and clicks each node on the screen. Then another small window (in the lower left corner) appears to input the RFID tag numbers which are set near the node. This process is repeated for every particular place on the floor plan. Finally, the user selects the menu to save the database in a file, which the robot can use for path planning.

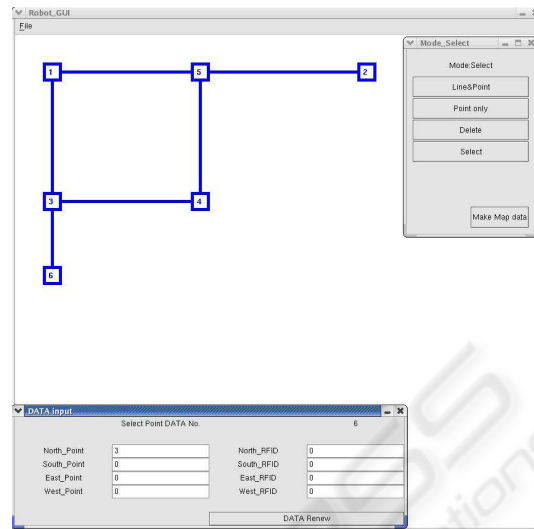

Figure 6: Interface for tracing a map.

## 4 ROBOT SYSTEM

Figure 7 illustrates the architecture of the navigation system. The system mainly consists of a navigation planning module, a graphical user interface (GUI) for tracing maps and a database of map information. The GUI as shown in Figure 6 enables us to make the database of map information from a floor plan. The database is a set of the data structure of nodes shown in Figure 5(b), which shows the relation of the particular places of the floor plan and assigned RFID tag numbers to each particular place. The navigation planning module decide a route to a given goal from sensed RFID tag numbers and the map information.

The navigation system was implemented on a host computer running on Linux and the mobile robot shown in Figure 1. The host computer manages the functions of the navigation planning module shown in Figure 7. The computer has two wireless RS-232c serial ports. It is responsible for handling the data from the RFID tag sensor through a wireless serial port and sending commands to the motor control module on the micro-controller of the mobile robot through another wireless serial port. The robot consists of a mobile platform and an RFID tag sensor. The mobile platform (approx. 35 cm square) is equipped with an on-board micro-controller, a two-wheel drive system with one rear free wheel, an odometer with optical encoders, seven ultrasonic rangefinders and an RS-232c serial port. The rangefinder units are mounted at the front of the robot as shown in Figure 8(a) for forward and lateral sensing and the sensitivity range is up to 5 meters. The micro-controller manages the motion control module for running the drive system and col-



lecting position and speed information from the drive encoders, including firing the sonar sensors and retrieving echo signals.

In our method the precise positions of RFID tags in a hallway is not known. Also, the robot is not aware of the length of hallways. The robot just follows the left side walls of the hallway until it finds a tag. It is essential that an mobile robot be able to realign itself relative to a wall and then proceed if it becomes disoriented. Man-made environments such as hallways are usually constructed with a horizontal plane (a floor area) and vertical planes (walls, pillars and doors). The boundary line formed by the floor and a wall becomes a long straight line which can be seen at any point in the scene. Since the RFID tags are pasted on vertical planes, the walls, the boundary lines can be used as a guide for navigation. The geometry of sensing the distance to a wall and measuring the orientation of the robot with respect to the wall is shown in Figure 8(b). The robot is equipped with seven rangefinders as shown in Figure 8(a). The lateral rangefinder views the left side wall at two points and measure the distance ( $d1, d2$ ) to the wall. The orientation of the robot with respect to the wall is calculated from the difference of the distances and the moving distance  $L$ .

Figure 9 shows the flow of motion control for the robot. The rangefinders are invoked every few meters of movement and generate the angle formed by a wall and the robot's direction and the perpendicular distance to the wall from the robot. The navigation planning module uses these data to change the orientation of the robot parallel to the wall and drives it along the wall maintaining the distance between the robot and the wall. The rangefinders also check for sudden obstacles for emergency stops. If a tag is detected while the robot is moving the navigation planning module recognizes the robot's location on the topological map from the ID number and then decides the next direction: the robot turns to the left, turns to the right, goes ahead or turns back. When changing the direction at an intersection the movement is controlled mainly by the rangefinders. The robot moves forward measuring the distance to both side walls with the rangefinders and find the center of the intersection from the measured distance. At the center the distance becomes huge because of no walls. Then, the robot turn to the indicated direction. After the robot passes an intersection the rangefinders are invoked again and the robot follows another hallway until it finds a tag.

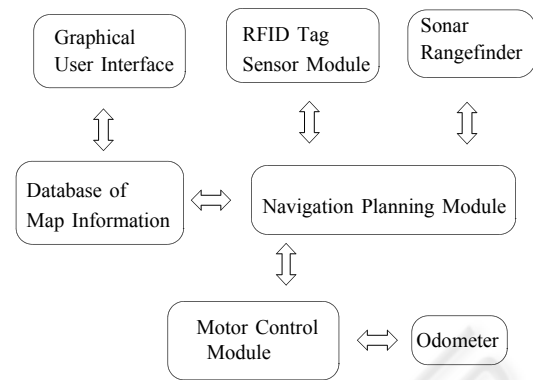

Figure 7: Architecture of the navigation system.

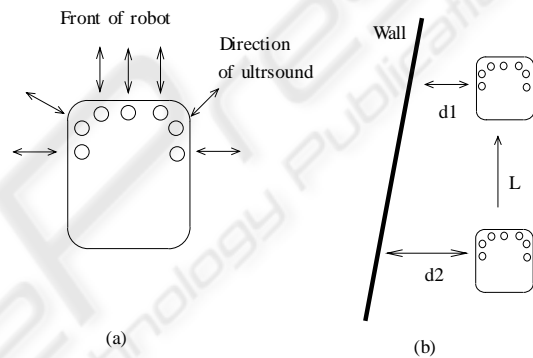

Figure 8: Sonar positions (a) and measuring the orientation of the mobile robot(b).

## 5 EXPERIMENTAL RESULTS

A typical test run of the mobile robot based on the navigation method is shown in the series of photographs in Figure 10. The sequence shows the robot starts near an RFID tag, orients itself in a junction and then traveling until it finds another RFID tag. This movement is similar to one along the route from the tag number 23 to 19 in Figure 5(a). The width of the passage was 1.6 m and the traveling distance along the passage was about 8 m. As shown in Figure 10(a) a tag was fixed on the low pole near the exit to a passage. Figure 10 (b) shows that the robot passed by the tag and the tag's ID number was detected by the RFID tag sensor. The navigation planning module decided next movement based on the tag's ID number. In this test run the robot was scheduled to turn to the right.

The robot moved for a while under the control of the odometer of the robot and then checked if the right side of the robot is a free space (i.e. no walls) using the ultrasonic rangefinders. This process was repeated until an enough space was found on the right side (see

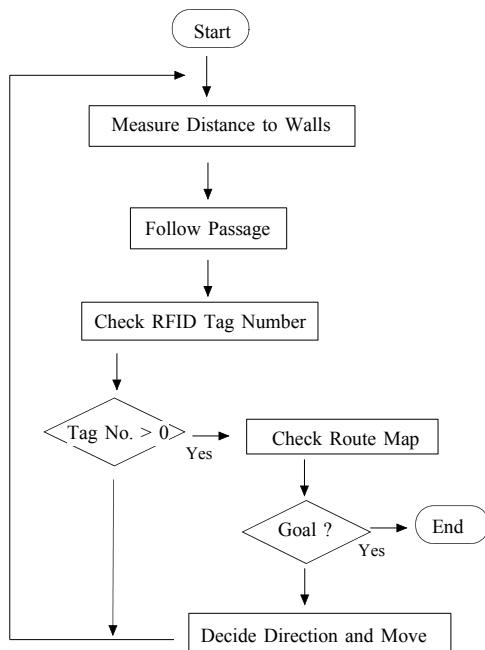

Figure 9: Flow of the navigation method.

Figure 10(c) and (d)). After that the robot turned to the right as shown in Figure 10(e) and (f). The robot moved along the passage (see Figure 10(g), (h) and (i)) and after every 1 m of movement, the rangefinder module was invoked. From the geometrical information the navigation planning module decided the rotation angle of the robot to reorient the robot parallel to the wall, and the distance needed to draw the robot near to the wall. To sense the RFID tags reliably the robot must move along the wall at a distance of less than 1 m. In this experiment the distance was 0.8 m. The sensor guidance with iterative sensing and motion continues until an RFID tag is found. In Figure 10(j) the robot suddenly faced the wall obliquely due to slip or something. The navigation plan module attempted to reorient the robot parallel to the wall (Figure 10(k)). After that, another RFID tag was detected and the robot stopped.

## 6 CONCLUSIONS

Mobile robots are a very imprecise mechanism. Navigation systems for mobile robots should have a mechanism to accomplish tasks with an adequate degree of precision. We thus proposed a topological navigation system using RFID tags and a sonar rangefinder system. The rangefinder was used to reorient the robot

parallel to a wall keeping the distance to it. We also introduced a topological connection map of the RFID tags, which can be built without precise 3-D representation of the environment. Robots just follow the tags under instructions of the topological map. The equipment setup is very simple and the navigation system is easily combined with the robot's computer systems. This is both practical and acceptable for the application of mobile robots to the real world.

A graphical user interface for making the world map conveniently is indispensable for the application of the navigation method. We have built an interactive system running on the Linux. This is an on-going project.

## REFERENCES

- Murphy, R. R. (2000). Introduction to AI Robotics. MIT Press.
- Hofmann-Wellenhof, B and et al. (2003). Navigation - principles of positioning and guidance. Springer.
- Fujii, T. and et al.(1997). Intelligent Data Carrier System for Cooperative Behaviors Emerge among Collective Robots. Proc. of IEEE International Conference on Systems, Man, and Cybernetics, Vol. 1, pp. 299-304.
- Kawamura, k and et. al.(2002). Toward Perception-Based Navigation Using EgoSphere. Proc. of SPIE, Vol. 4573, pp. 137-147.

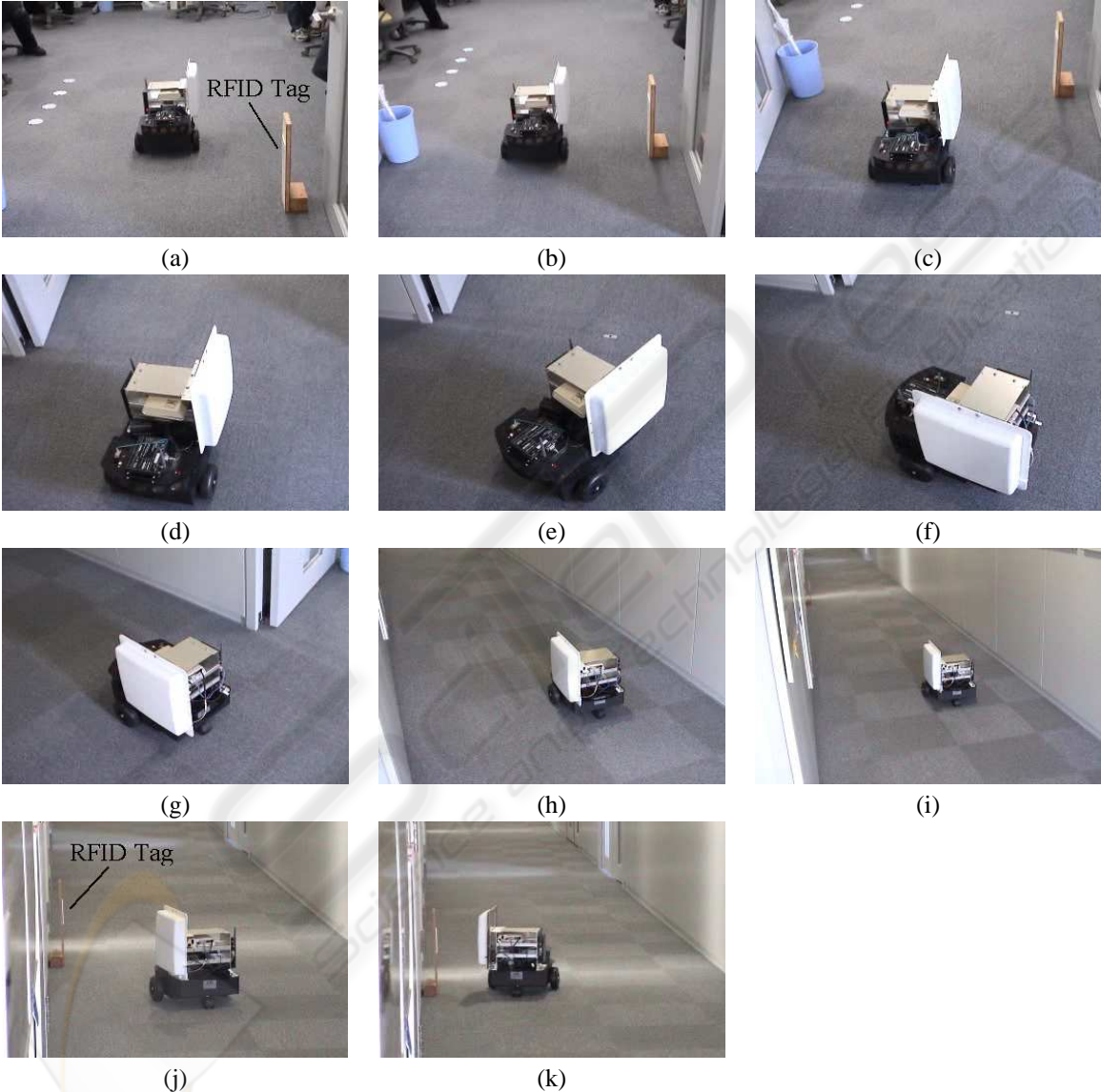

Figure 10: Test run of the mobile robot.