

INTRODUCING A MOBILE SYSTEM FOR THE EARLY DETECTION OF CARDIAC DISORDERS AS A PRECAUTION FROM A CARDIOLOGISTS' VIEW

Evaluation of a Survey

Onur von Burg, Marco Savini, Henrik Stormer and Andreas Meier
University of Fribourg, Boulevard de Prolles 90, 1700 Fribourg, Switzerland

Keywords: Cardiology m-health e-health mobile survey heart.

Abstract: This paper illustrates the results of a survey of practicing cardiologists that were asked about various aspects of a simplified telecardiology scenario using mobile devices. Such devices are becoming ubiquitous assets in everybody's life. Their application in a healthcare environment aims not only at supporting the patients over traditional consultations but also maximizes the content of their health status information. The results of the survey may help application developers to focus their efforts of applications in a similar setting.

1 EHEALTH AND MHEALTH

(Haas, 2006) defines eHealth as

...the application of Internet and other related technologies in the health care industry to improve access, efficiency, effectiveness, and quality of clinical and business processes used by health care organizations, practitioners, patients, and consumers to improve the health status of patients.

mHealth extends this notion by considering mobile actors (patients, health professionals, ...) and their environment. (Istepanian et al., 2006) simply define it as "emerging mobile communication and network technology for health care". Certain areas of eHealth like monitoring over distance can be greatly improved when considering ubiquitous mobile devices. (del Pozo et al., 2006) defines that potential needs should meet certain criteria so that:

- eHealth services should be provided at any time and any place, depicting the need for efficient, ubiquitous and secure institutional care.
- Efficient coordination tools should be provided to all health professionals dealing with each single patient, in order to allow the implementation of patient centered care.

The recent advances in mobile technology like higher bandwidths or powerful smartphones with ad-

vanced features allow the creation of new medical applications that support both patients and doctors.

A number of researchers have worked on the idea of assigning mobile devices to patients. It is possible to distinguish between the following three domains:

1. Mobile devices are used to help the patient by providing information.
2. Mobile devices are used to transmit physiological parameters.
3. Mobile devices are used to alert patients or medical professionals when certain physiological parameters become critical.

The dialogue-based monitoring system in (Komninou and Stamou, 2006) aims at supporting elderly people in their preferred environment and can therefore be assigned to the first domain.

The MOEBIUS project (Mobile extranet-based integrated user services) that integrates doctors and patients by submitting different physiological parameters (Fischer et al., 2006) can be considered as an application of the second domain. Similarly, (Leimeister et al., 2005) describes the usage of mobile devices in order to assist young cancer patients and concludes that the usage of such a system has a number of advantages: higher compliance of appointments with alerting functionality, higher data quality, less work for the doctor to prepare the documentation as well as less errors in the documentation. The use of context

von Burg O., Savini M., Stormer H. and Meier A. (2008).

INTRODUCING A MOBILE SYSTEM FOR THE EARLY DETECTION OF CARDIAC DISORDERS AS A PRECAUTION FROM A CARDIOLOGISTS'

VIEW - Evaluation of a Survey.

In *Proceedings of the First International Conference on Health Informatics*, pages 44-50

Copyright © SciTePress

in a mobile healthcare scenario using the information groups Who, Where, When, Why and What has been described in (Savini et al., 2007).

An example of the third domain collecting real-time electrocardiogram signals including basic arrhythmia detection with automatic alerting to a call center is illustrated in (Liszka et al., 2004). Their system architecture uses readily available commercial off-the-shelf components.

1.1 Cardiology

1.1.1 Overview

Cardiovascular reasons represent the largest cause of death in Switzerland with 37% of all deaths in 2004 (Junker, 2007). It is followed by cancer related deaths with 26%. While the percentage of cardiovascular related deaths of the 65 years and older increases to 41.7%, it still contributes with 20% of all deaths within the younger age group of the 45 to 64 year olds. Similar data exists in the EU with approximately 40% of all deaths related to cardiovascular diseases (Eurostat, 2002, Chapter 8).

1.1.2 Cardiac Disorders

In (Guidant, 2007) the following general types of heart diseases are identified:

Problems with the Heart's Electrical System. If the tissue that produces and sends electrical impulses to the heart muscle is damaged, abnormal heart beatings can occur in different variants: Bradycardia (unusually slow or unsteady rhythm), Tachycardia (more than 100 beats per minute), Atrial fibrillation (the upper chambers of the heart beat between 300 and 600 times per minute) and Sudden Cardiac Death (heart stops to beat and pump suddenly and unexpected).

Problems with the Heart's Arteries. These problems represent the most common heart disease in western countries. Fatty plaque builds up in the arteries and less blood flows through the heart muscle. This is illustrated in figure 1.

Problems with Arteries Outside the Heart. This disease type also identifies the building up of fatty plaque, but outside the heart, so less blood flows through the body. If the blocked artery is supplying the brain with blood, the patient may experience a stroke in the worst case.

A thorough introduction into cardiology is given in (Crawford et al., 2003).



Figure 1: Coronary heart disease (Know Heart Diseases, 2007).

1.1.3 ECG

An electrocardiogram can be defined as a non-invasive test to reflect underlying heart conditions by measuring the electrical activity of the heart and producing an output in the form of a continuous strip graph. Early analysis and exploration of the heart's electrical system and its measuring techniques were examined by Willem Einthoven in the early 1900's (Biel et al., 2001).

The basic approach is to put electrodes on the body. The following three types of ECGs can be identified:

Resting. Taken within a couple of seconds.

Activity. Taken under physical activity.

Long-term. Usually taken during a 24 hour period.

The number of leads indicates the quality of the measurement. 12 leads ensure that all parts of the heart are recorded. It is generally accepted that ECG measurements with 3 leads ensure credibility (Burger and Osswald, 2003).

Various research has already been conducted regarding the transmission of ECG data. (Nollo et al., 2000) describes the national project "Territorial Telecardiology" which focuses on providing experts with ECG data from medical ambulatory locations and patients homes. The average time of response is 1.5 days. The project demonstrated the feasibility and utility of a telecardiology network that offers improved access and quality in rural areas.

The design of a wearable device for ECG monitoring has been presented in (Led et al., 2004). The paper describes the usage of Bluetooth technology to transfer the ECG data to a mobile base unit.

Compression of ECG data is a topic that is very important in a homecare scenario, due to the limited bandwidth available over mobile networks and the high amount of data which is generated. An overview of various methods and research for the compression of biosignals is given in (Hadjileontiadis, 2006).

Table 1: Return rates.

Region		Infrastructure		Size of Location		
German	French	Hospital	Practice	> 100'000	> 30'000	< 30'000
35.7%	35.6%	61.5%	33.1%	29.2%	26.3%	45.4%

2 SURVEY RESULTS

The main motivation for the survey was to understand how cardiologists think about a telemonitoring system as an instrument for the detection of heart-related disorders. The main goal hereby was to research various components of how such a system should be built and what focus it should have in order to receive a high acceptance with the people that will eventually have to introduce such a system to the patients.

2.1 Approach

The printed questionnaires were sent on the 13th of March 2007 to 277 (out of totally 533) practicing cardiologists in Switzerland. French and German questionnaires were used to address the corresponding linguistic regions in Switzerland. The Italian region was not considered in this survey. 100 questionnaires were returned without any special follow ups, resulting in a total return rate of 36.1%. Table 1 illustrates the various return rates relative to various variables.

2.2 Structure of the Questionnaire

In order to design the questionnaire, some aspects from (Berekhoven et al., 2006) were applied:

- Interesting subject matter.
- Questionnaire as short as possible.
- Composition as interesting as possible.
- Questions as logical and easy as possible (optical as well).

Prior to the creation of the questionnaire an interview was held with a practicing cardiologist who has some background in the field of telecardiology. The result was a total of 12 questions that can be grouped into two categories:

- Questions regarding ICT usage in cardiology in general.
- Specific mobile telecardiology application related questions.

A simplified process of a possible mobile telecardiology use case was illustrated on the first page of the questionnaire in order to give the respondents an idea about the intention of the survey.

The box-and-whisker diagrams used throughout this paper in order to illustrate the responses use a filled circle as median of the response and the position of the dot within the box gives an indication about the skew of the data. The dotted lines define the whiskers which can be seen as the smallest or biggest non-outlier observations. Eventual outliers are drawn as empty circles.

2.3 ICT in Cardiology

Two questions address the use of ICT within cardiology. In one question, the cardiologists were asked about their opinion on how they judge the desire of their patients to have innovative applications for treatment and diagnosis. 28.3% of the cardiologists think that their patients have a fairly strong desire for innovative applications. The correlations of these results with the demographic variables shows that the geographical region or the size of the location of the cardiologists does not influence the results. However, there is a correlation to the type of infrastructure the cardiologists operate in, indicating that cardiologists working in hospitals evaluate the desire of patients for new medical applications slightly higher than cardiologists in practices (see figure 2).

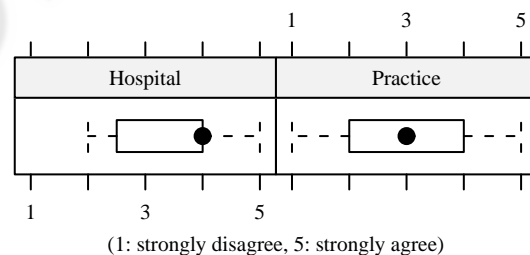

Figure 2: ICT usage for patients in cardiology.

The second question regarding ICT addresses the perspective of the cardiologists and asked if ICT is used sufficiently in cardiology. The mean is very similar to the former question. Compared to the infrastructure the cardiologists operate in, there is no difference between practices and hospitals, unlike to the former question. The results for both questions are illustrated in figure 3.

In summary, the following statements can be made in regard to ICT usage in cardiology:

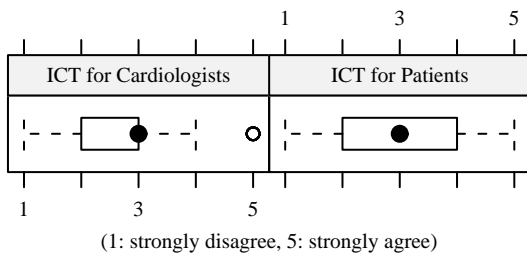

Figure 3: ICT usage in cardiology.

- Patients have a certain desire for innovative applications in cardiology.
- Hospitalized patients have a higher desire for additional ICT in cardiology than patients in practices.
- Cardiologists feel that today's ICT usage in cardiology is fairly sufficient.

2.4 Motivation and Components in Telecardiology

Questions regarding the components in a telecardiology setting can be broken down into three main categories: The *Patient* category analyzes the abilities and the reasons of patients to use such a system. The questions in the category *Patient-end System Components* emphasize on various scenarios and number of leads that are necessary to measure an ECG. Furthermore, it investigates if the viewing of the ECG on a mobile base unit makes sense. The final category *Cardiologist-end System Components* ad

2.4.1 Patient Ability

The cardiologists were asked to evaluate the ability of their patients within certain age groups to record and send their ECG data in a given scenario. The results shown in figure 4 are not surprising. Cardiologists judge that about half of their 60 to 70 years old patients are able to record and send ECG data. The confidence is considerably higher for their younger patients.

2.4.2 Reasons for Patients

Possible reasons for using such a telecardiology system were investigated in a separate question. The total results, independent of the infrastructure or geographical region, are summarized in table 2.

Not surprisingly, the number one motivation is giving better access to patients living in rural areas. Cardiologists living in hospitals consider this even

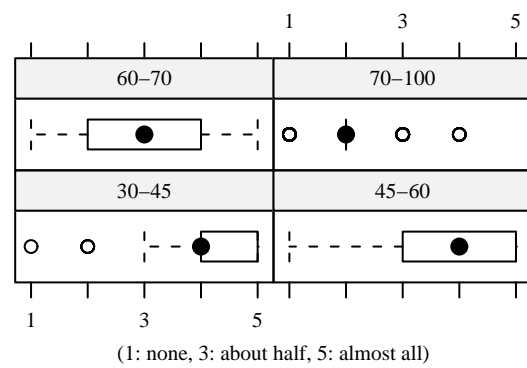

Figure 4: Patient ability per age group.

Table 2: Possible reasons for patients.

Reason	Agree
Cardiac patients who live in rural areas	58.6%
High quantity of elderly patients with limited mobility	42.4%
Higher service in quality and treatment	39.4%
Growth of mobile users with easiness to send ECG data	36.4%
Time gain for patients	32.3%
Reduction of costs	18.2%

more important (75%) than their colleagues in practices (55%). The next four reasons are all rated with about the same importance. Interestingly, although cardiologists assess elderly patients as less able to use such a mobile application (see figure 4), their limited mobility is ranked as number two reason. Furthermore, the possible time gain for patients using such a solution is judged positively by 50% of all cardiologists in hospitals as an important reason, whereas only 29% of practices see it like that.

2.4.3 System Components for Patients

This section of the questionnaire addresses various component settings and scenarios on the patient side for a mobile telecardiology application.

The first question considers various usage scenarios for patients and asked the cardiologists to evaluate their view which is illustrated in figure 5.

Only one of the proposed scenarios, the permanent transmission of ECG data for high risk patients, received a relatively high response. Regarding the periodic transmission of ECG data as a precaution, the cardiologists in big cities valued it slightly higher (mean 2.06) than their colleagues in towns (mean 1.79); this could be explained with the fact that cardiologists in big cities tend to treat more patients for routine check-ups.

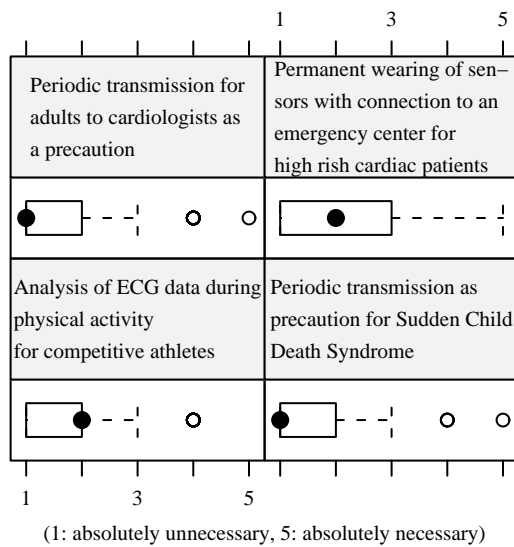

Figure 5: Usage scenarios.

The second question addresses the number of ECG leads necessary for a mobile application in order to reliably record the ECG of a patient. The distribution in figure 6 clearly illustrates two preferences: 3 leads and 12 leads.

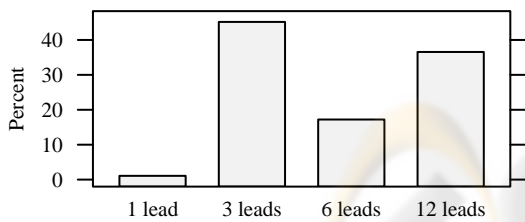

Figure 6: Number of leads preference.

The evaluation of the effectiveness of diagnostics using a mobile application for the three main types of cardiac diseases is addressed in the third question and its results illustrated in figure 7.

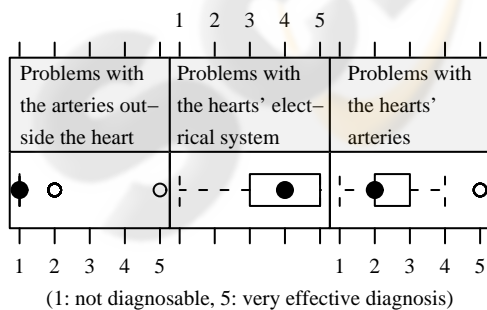

Figure 7: Evaluation of disease types.

Problems with the arteries outside the heart do not represent situations that can be diagnosed using ECG sensor leads. In relation to the number of leads, patients that have problems with the hearts' arteries typically will use 12 leads and such applications will have to consider the larger data sets required. For patients that use such a mobile application as precaution for the heart's electrical system, a 3 lead ECG sensor appears to be more realistic.

The final question regarding the system components on the client side investigates the need of the patient to view his own ECG data on the mobile base unit. The results in figure 8 show that cardiologists do not consider such a functionality very desirable for their patients. This might be due to the fact that ECG diagrams can be quite complex to read and should thus only be analyzed by experienced professionals.

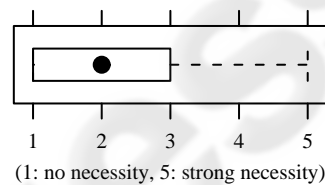

Figure 8: Patient desire to view ECG on MBU.

2.4.4 Components in Telecardiology for Cardiologists

The final part of this section considers the various components of a mobile telecardiology solution for the cardiologists themselves. It consists of two questions: The first question addresses the ICT knowledge of the cardiologists based on possible components or technologies that could be used for such a solution and is illustrated in figure 9.

Internet applications, mobile communication, information system and PDAs rank highest in the list and except for technical terms many possible components and technologies seem to be known reasonably well. Cardiologists in practices tend to have similar or slightly higher knowledge in regard to Internet Applications, as figure 10 illustrates. The same is true for mobile technologies and other fields.

This explains also the results of the next question: The cardiologists were asked about their preferences how they would like to receive the ECG data of the patients for the various scenarios already interrogated in figure 7. A summary of the preferences is ranked in table 3.

However, the results in figure 11 make it obvious that the preferred end system heavily relies on the kind of disease type that is handled with the solution.

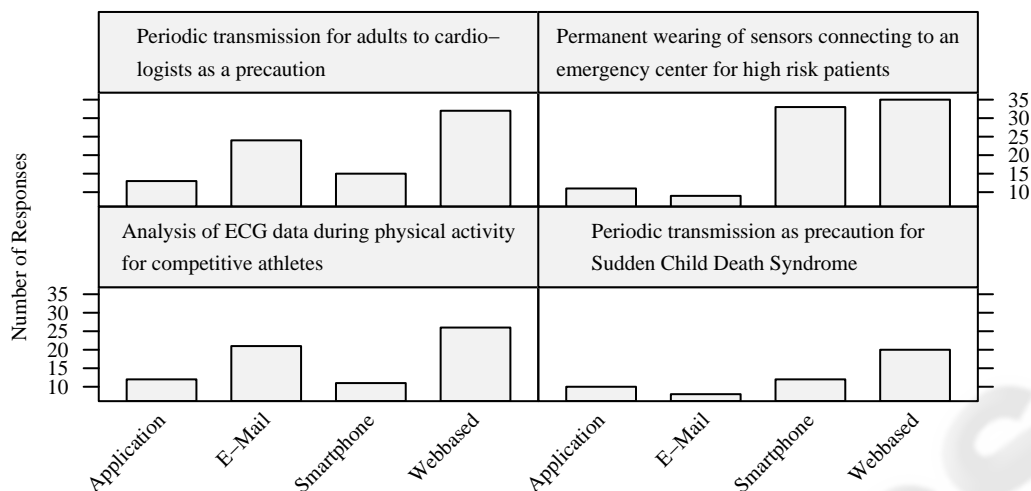
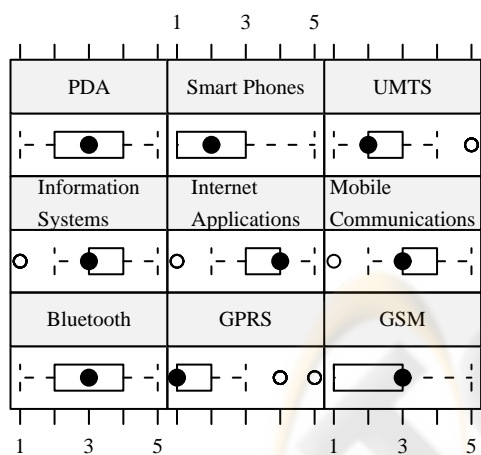
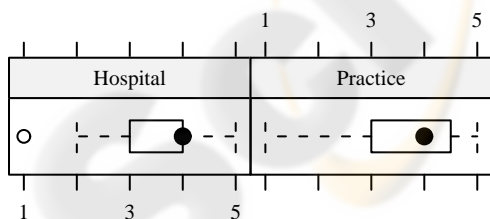

Figure 11: Preferred end systems per disease type.



(1: never heard of, 3: user knowledge, 5: extensive knowledge)

Figure 9: ICT knowledge of cardiologists.



(1: never heard of, 3: user knowledge, 5: extensive knowledge)

Figure 10: Knowledge about internet applications.

Web-based solutions seem to be a good choice in most cases. However, smart phones get a very high rating when the application handles high risk patients

Table 3: Ranked summary of preferred end systems.

System	Preference
Web-based solution	38.7%
Smart Phone	24.3%
E-Mail with attachment	21.2%
Dedicated application	15.8%

in an emergency. In such a situation, an e-mail that may take from minutes up to hours to arrive to the cardiologist, is not acceptable, even if the emergency is handled by a dedicated center. However, e-mails seems to be perfectly acceptable if the matter is about observing a patient over a longer period of time as a precaution.

3 CONCLUSIONS AND OUTLOOK

The work in this paper focuses on the actual needs of a mobile telecardiology application with the results obtained from the survey. The conducted survey allows several conclusions for the implementation of a mobile application in cardiology:

- Except for the oldest age group (70-100), cardiologists agree that their patients are able to use such a system.
- Cardiologists do not seem enthusiastic about the proposed usage scenarios. However, a combination of factors, such as high risk patients in rural

areas, may strongly contribute to a higher acceptance.

- Addressing problems with the hearts' electrical system seems to be a widely accepted disease type for such a mobile application.
- There does not seem to be a strong desire for the patients to view their own ECG.
- The ICT knowledge of cardiologists and their preferences imply that, except for emergency situations, an internet application would be a good choice for their end system.

Security issues have explicitly been factored out of the questionnaire in order not to overwhelm the cardiologists with technical details. However, such issues are a pivotal part of every health related application and contribute highly to the acceptance and credibility of a system.

3.1 Outlook

In this paper we illustrated the perspective of cardiologists regarding a mobile telecardiology application scenario for patients. We would like to extend our research in the following areas:

- A survey on the patients may give insights about what elements to consider on the client side. It would be interesting to analyze the technological knowledge split by age group and the willingness of patients to use such a system when offered some well-defined benefits.
- The usage of standard equipment greatly contributes to a seamless rollout to the public. We would like to investigate how existing technologies can be integrated in order to provide a solution that aids the patients and cardiologists and that is also cost-effective.
- Qualitative interviews with cardiologists might give us a better idea about possible usage scenarios.

REFERENCES

- Berekhoven, L., Eckert, W., and Ellenrieder, P. (2006). *Marktforschung – Methodische Grundlagen und praktische Anwendung*. Gabler Press.
- Biel, L., Pettersson, O., Philipson, L., and Wide, P. (2001). ECG Analysis – A new approach in Human Identification. *IEEE Transactions on Instrumentation and Measurement*, 50:808–812.
- Burger, P. and Osswald, S. (2003). Das EKG in der Telemedizin. *Swiss Medical Forum*, 3:661–643.
- Crawford, M. H., DiMarco, J. P., and Paulus, W. J., editors (2003). *Cardiology*. Mosby, 2 edition.
- del Pozo, F., de Toledo, P., Jimenez, S., Hernando, M. E., and Gomez, E. J. (2006). Chronic Patient's Management: The COPD example. In *M-Health – Emerging Mobile Health Systems*, pages 575–585. Springer.
- Eurostat (2002). *Health statistics – Atlas on mortality in the European Union*. European Commission.
- Fischer, H.-R., Reichlin, S., Gutzwiller, J.-P., Dyson, A., and Beglinger, C. (2006). Telemedicine as a new possibility to improve health care delivery. In *M-Health – Emerging Mobile Health Systems*, pages 203–218. Springer.
- Guidant (2007). Heart Disease and Cardiovascular Disease Therapies. <http://www.guidant.com>. accessed on 5th June 2007.
- Haas, P. (2006). eHealth verändert das Gesundheitswesen – Grundlagen, Anwendungen, Konsequenzen. *HMD Praxis der Wirtschaftsinformatik*, 251:6–19.
- Hadjileontiadis, L. J. (2006). Biosignals and Compression Standards. In *M-Health – Emerging Mobile Health Systems*, pages 277–292. Springer.
- Istepanian, R. S., Laxminarayan, S., and Pattichis, C. S. (2006). Ubiquitous m-health systems and the convergence towards 4G mobile technologies. In *M-Health – Emerging Mobile Health Systems*, pages 3–14. Springer.
- Junker, C. (2007). *Todesursachenstatistik – Ursachen der Sterblichkeit 2003 und 2004*. Bundesamt für Statistik.
- Know Heart Diseases (2007). Know Heart Diseases. <http://www.know-heart-diseases.com>. accessed on 5th June 2007.
- Kominos, A. and Stamou, S. (2006). HealthPal: An Intelligent Personal Medical Assistant for Supporting the Self-Monitoring of Healthcare in the Ageing Society. In *Proceedings of UbiHealth 2006*.
- Led, S., Fernandez, J., and Serrano, L. (2004). Design of a Wearable Device for ECG Continuous Monitoring Using Wireless Technology. In *Proceedings of the IEEE EMBS*, pages 3318–3321.
- Leimeister, J. M., Krcmar, H., Horsch, A., and Kuhn, K. (2005). Mobile IT-Systeme im Gesundheitswesen, mobile Systeme für Patienten. *HMD – Praxis der Wirtschaftsinformatik*, 244:74–85.
- Liszka, K. J., Mackin, M. A., Lichter, M. J., York, D., Pillai, D., and Rosenbaum, D. S. (2004). Keeping a Beat on the Heart. *IEEE Pervasive Computing*, 3(4):42–49.
- Nollo, G., Nones, M., Malossi, C., Conforti, F., and Batoletti, B. (2000). Standard communication protocol for ECG exchange in tele-cardiology network for rural areas: three years project experience. *Computers in Cardiology*, 27:663–666.
- Savini, M., Stormer, H., and Meier, A. (2007). Integrating Context Information in a Mobile Environment using the eSana Framework. In *Proceedings of the ECEH'07*, pages 131–142.