

# EFFICIENT EVALUATION OF THE INFLUENCE OF ELECTRIC PULSE CHARACTERISTICS ON THE DYNAMICS OF CELL TRANS-MEMBRANE VOLTAGE

N. Citro, L. Egiziano, P. Lamberti and V. Tucci

*Dept. of Electrical and Information Engineering, University of Salerno, Via ponte don Melillo, Fisciano (SA), Italy*

**Keywords:** Electroporation, Trans-Membrane Voltage, Design Of Experiments, Response Surface Method, Hodgkin-Huxley model.

**Abstract:** This paper aims at presenting a systematic approach for evaluating the effects induced on the dynamics of the Trans-Membrane Voltage of a biological cell by the characteristics of the non-ideal (trapezoidal) applied electric pulses. The proposed methodology is based on a combined use of the Design of Experiments (DoE) and Response Surface Methodology that allows to put in evidence the self and mutual effects produced by the characteristic parameters of the pulse (slew rate, the total duration of the impulse and its amplitude) on the time evolution of the Trans-Membrane Voltage (TMV). In particular, the effects on the max instantaneous value of the TMV are analysed: its qualitative behaviour vs. the considered parameters, the combination of parameters leading to the highest amplitude and the most influencing parameter are identified with an efficient search based on an optimal set of numerical trials. The analysis concerning the dependence of the max value of TMV on the pulse parameters is performed by considering either a basic Hodgkin-Huxley (HH) circuit or a modified one taking also into account the electroporation phenomenon.

## 1 INTRODUCTION

An externally applied electrical field pulse determines fast structural modifications of the plasma membrane of biological cells. This phenomenon, known as electro-permeabilization or electroporation has been proposed as an efficient tool to interact with biological materials in several applications. An irreversible electroporation has been used in biology for the decontamination of water and in food processing for the nonthermal killing of harmful microorganisms (Joshi et al., 2004). On the other side, a transient membrane permeabilization has been proposed in medicine for gene therapy, cancer chemotherapy, drug delivery, etc. (Sukharev, et al., 1992, Weaver 2000). In fact, the application of a pulsed electric field has been shown to improve the uptake of drug with respect to conventional methods (Hofmann, et al. 1999). The most remarkable phenomena associated to electroporation are linked to the formation of pores in the lipid bilayer membrane and the growth of their dimensions. The opening of these gateways allows the transport of ions and water-soluble species

through the membrane (Beebe et al., 2001, Neumann et al., 1989).

In order to study how the characteristics of the externally applied electric field pulses influence the cell dynamics, either field or circuit-based models approaches have been used (Miller and Henriquez, 1988, Heida et al., 2002). The field-based models, although allowing very detailed determinations of the relevant quantities, require great efforts in modelling the different cellular subsystem and in performing the computations by suitable numerical schemes (FEM, BEM, etc.) in time domain. The circuit-based models are less accurate but more flexible and easy to manage. Moreover, a straight association of the electrical quantities to the biological transport phenomena can be achieved. The lumped parameters circuits employed to represent a small patch of the biological cell can be derived from the so called Hodgkin-Huxley (HH) model after their seminal work concerning the conduction and excitation of nerve membranes (Hodgkin and Huxley, 1952). In this model the membrane is represented by a capacitance, the ionic channels as linear or nonlinear conductances and the voltage generators are linked to the so called Nernst

equilibrium potential, determined by the ratio of the specific ionic concentrations inside and outside the cell. An improved model, where a voltage controlled current generator takes into account the electroporation phenomenon, has been recently proposed (Citro and Tucci, 2006).

The circuit approach is adopted in a large number of papers in order to perform an easy and efficient analysis of the modifications of the cell response to either the variations of the circuit parameters (Citro et al, 2005), or those associated to the input voltage and current characteristics (Bilska, DeBruin, Krassowska, 2000). However, in most cases the identification of the parameters ranges, in which the variability of the response is studied, seems to be carried out with rather naïve criteria.

For this reason, in this paper a systematic approach based on the Design of Experiments (DoE) and Response Surface Methodology (RSM) is used in order to evaluate the most influencing parameters on the dynamics of Trans-Membrane Voltage (TMV) of a cell subjected to a non ideal pulse field modelled by means of a trapezoidal voltage pulse  $v(t)$ . The slew rate ( $dv/dt$ ), the total duration of the impulse  $t_{hold}$  and its amplitude  $V_{max}$  are considered as factors of influence. In particular, the effects induced on the maximum value of TMV are studied. The combination of parameters which determines the highest amplitude of TMV and the most influencing parameter (i.e. the max value of the applied pulse) are identified by a suitable choice of tests. The adopted approach, whose efficiency relies in the limited number of proper numerical trials needed, allows also to put in evidence the qualitative behaviour of the TMV vs. the considered parameters. A HH circuit, in which the electroporation phenomenon may be taken into account by a voltage controlled current generator, is considered. The obtained results concerning the TMV dynamics favourably compare with those obtained by other researchers (DeBruin and Krassowska, 1999, Kotnik and Miklavcic, 2006, Vasilkoski et al., 2006). After a brief description of the adopted circuit model in Sect. 2, the application of the DoE is presented in Sect.3. In Sect. 4 the results obtained by RSM are discussed and in Sect. 5 the main conclusions are drawn.

## 2 CIRCUIT MODEL

The analysis is carried out for the modified HH circuit shown in Figure 1 which mimics the behaviour of a cell membrane patch subjected to a

trapezoidal voltage pulse. The circuit takes also into account the behaviour of the biologic solution outside the cell (the parallel  $C_{ext}-g_{ext}$ ) and the internal cytoplasm (the parallel  $C_{cyt}-g_{cyt}$ ).

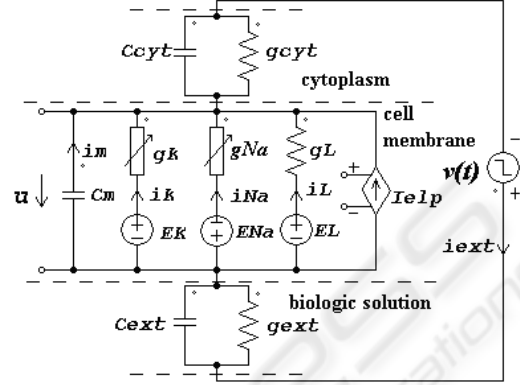

Figure 1: Modified HH circuit.

The details of the model are discussed in (Citro and Tucci, 2006). Here we just summarise the main aspects. The Kirchhoff current law applied to the circuit of Figure 1 gives:

$$C_m \frac{du(t)}{dt} = i_{ext}(t) - [I_{elp}(t) + i_L(t) + i_K(t) + i_{Na}(t)] \quad (1)$$

In fact the total ionic current is given by four contributions. The first three contributions (leaking channel current  $i_L$ , sodium channel current  $i_{Na}$ , potassium channel current  $i_K$ ) are the same of the basic HH circuit and therefore  $g_L$  is a constant value whereas  $g_{Na}$  and  $g_K$  are non linear time dependent conductances such that  $g_{Na} = g_{Na,max} \cdot m^3 \cdot h$  and  $g_K = g_{K,max} \cdot n^4$  where  $m$ ,  $n$  and  $h$  are nonlinear variables describing the activation or inactivation of the channels and given by a first order non linear differential equation (Hodgkin and Huxley, 1952). The fourth is the electroporation current, given by a voltage controlled current source  $I_{elp} = N \cdot i_{elp}$  where  $i_{elp}$  is the current through a single pore and  $N$  is the pore density governed by the Smoluchowsky-equation:

$$\frac{dN(t)}{dt} = \alpha e^{(u(t)/V_{ep})^q} \left( 1 - \frac{N(t)}{N_0} e^{-q(u(t)/V_{ep})^q} \right) \quad (2)$$

where  $u(t)$  is the Trans-Membrane Voltage (TMV),  $N_0$  is the pore density for  $u(t)=0$  and  $\alpha$ ,  $V_{ep}$  and  $q$  are suitable constants (DeBruin and Krassowska, 1999). By using the characteristic equation of the

membrane capacitance it results that the dynamic evolution of the TMV and the different ionic currents can be determined by evaluating at each time step a non linear differential equation system in 5 unknowns  $u, m, n, h, N$ :

$$\mathbf{Y} = [u(t), m(u, t), n(u, t), h(u, t), N(t)]^T$$

$$\begin{cases} \frac{d\mathbf{Y}}{dt} = \mathbf{f}(t, m, n, h, u, N) = \mathbf{f}(t, \mathbf{Y}) \\ \mathbf{Y}|_{t=0} = \mathbf{Y}_0 \end{cases} \quad (3)$$

In Table 1 the values adopted for the different quantities appearing in (1)-(3) are reported.

Table 1: Values of the parameters adopted in the model.

$g_L$	$g_{Na,max}$	$g_{K,max}$	$g_{cyt}$	$g_{ext}$
0.3 mS/cm <sup>2</sup>	120 mS/cm <sup>2</sup>	36 mS/cm <sup>2</sup>	24 S/cm <sup>2</sup>	24 S/cm <sup>2</sup>
$u_0$	$E_L$	$E_{Na}$	$E_K$	$V_{ep}$
0 mV	49.39 mV	55 mV	72 mV	258 mV
$C_{cyt}$ $C_{ext}$	$C_m$	$N_0$	$q$	$\alpha$
14.16 6 nF/cm <sup>2</sup>	1 μF/cm <sup>2</sup>	1.5·10 <sup>5</sup> 1/cm <sup>2</sup>	2.46	100 cm <sup>2</sup> ms <sup>-1</sup>

The numerical system (3) has been solved by using the commercial software FlexPDE.

### 3 DOE METHOD FOR THE BEST SET OF PARAMETERS

Design of Experiments (DoE) is a well known technique adopted in experimental or numerical campaigns. It allows the minimisation of the number of tests intended for the identification of the most relevant factors affecting the behaviour of a system. DoE methods allow to ascertain the relative importance of the different parameters and get indications on their interactions. In our case the characteristics of the trapezoidal electric pulse depicted in Figure 2 applied to the HH circuit represent the degrees of freedom considered in our application of DoE. The values of the parameters are chosen in suitable ranges reported in Table 2 according to those suggested in other works (Joshi et al., 2004, Kotnik and Miklavcic, 2006).

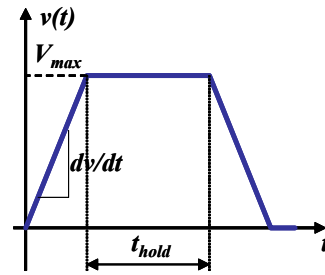

Figure 2: Shape and relevant parameters of the applied electrical pulse.

In order to have an effective but not too heavy scan of the possible range of the parameters space, we choose 9 distinct levels for the slew rate, and 3 for both  $t_{hold}$  and  $V_{max}$ .

Table 2: Parameters considered for the DoE and their levels.

Parameter	encoding	Number of levels	range values
$dv/dt$ [V/ns]	X1	9	[0.25;34.30]
$t_{hold}$ [ns]	X2	3	[11.0;280.0]
$V_{max}$ [V]	X3	3	[10.0; 60.0]

The total number of experiments for a full factorial design would be  $9*3*3=81$  points in the parameters space, i.e. the compact  $D$  defined as  $D = [X1_{min}, X1_{max}] \times \dots \times [X3_{min}, X3_{max}] \subset \mathbb{R}^3$ . Each experiment is a vector  $\underline{X}=(X1,X2,X3) \in D$ . However, since some combinations of parameters are unfeasible (as for example, when  $t_{hold}$  is lower than the sum of rise and fall time), the design matrix results in a reduced set of experiments which in our case is equal to 57. As a response  $Y$ , we consider the maximum value of the TMV with ( $Y_{elp}$ ) or without electroporation ( $Y_{nelp}$ ):

$$Y = \max_t u(t, \underline{X}) \quad (4)$$

The design of experiments plot (dex scatter plot) (NIST/SEMATECH, 2006), also known as main effects plot, reported in Figure 3 allows to put in evidence the most influencing factors and the best choice for the setting parameters. In this Figure the values of the response  $Y_{elp}$  are reported in correspondence of a fixed level of a given parameter, whereas the other two are varied from the min (-) to the max (+) value of the corresponding range.

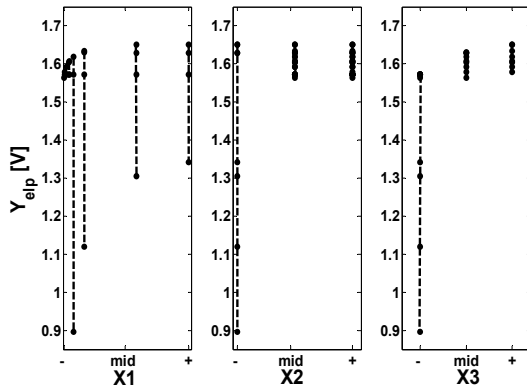
 Figure 3: Three factors - dex scatter plot of  $Y_{elp}$ .

In a dex scatter plot a factor can be considered as principal one if, when scanning its variability range from the min to the max value, it produces a significant change in the response. By analyzing the Figure 3 we can observe that X3 appears to be a principal factor. In fact, we have a great excursion in the response for the min of X3 whereas the responses are concentrated in a small interval for both the mid point value and for the max of X3. Furthermore, the values of the response increase as X3 increases. Also for X2 an effect similar to X3 in terms of excursion in the responses is evident: a great excursion for the min of X2, whereas the responses are concentrated in a small interval for its midpoint and max level. Indeed, the ranges of  $Y_{elp}$  when X2 is fixed at its second or third level are nested, with the third including the second: this implies a lower dependence of the response with respect to that due to X3 and a second order dependence. Instead the amplitude of the response due to changes in the X1 levels does not exhibit sensible variations. A low shift in the maximum value corresponds to a limited first order influence of this factor. Moreover, the factors combination allowing the max value in the response is achieved when  $X1=\max$ ,  $X2=\text{midpoint}$ ,  $X3=\max$ , as evidenced in the following paragraph.

#### 4 APPLICATION OF THE RESPONSE SURFACE METHOD

The Response Surface Method (RSM) allows to get quantitative information on the dependence of the response on the considered factors. In order to perform such an analysis, the results of the numerical simulations are interpolated on a response

surface. In particular, the response surface can be obtained by considering a second order model representing an hyper-surface in a 4-dimensional space:

$$y = \beta_0 + \sum_{i=1}^k \beta_i x_i + \sum_{i=1, j \leq i}^k \beta_{ij} x_i x_j \quad (5)$$

where  $y$  is the desired response (i.e. the maximum value of the simulated TMV),  $k$  is the number of the parameters,  $x_i$  ( $i=1, \dots, k$ ) represents the  $i$ -th factor,  $\beta_i$  and  $\beta_{ij}$ , ( $i, j=1, \dots, k$ ) denote the effect of  $i$ -th factor and the mutual interaction of  $i$ -th and  $j$ -th factor respectively. By using the previous 57 combinations of the parameter levels we obtain the RSM coefficients, summarized in Table 3 .

Table 3: RSM coefficients at a confidence level of 99%.

<b>Factor</b>	<b>1</b>	<b>X1</b>	<b>X2</b>	<b>X3</b>	<b>X1<sup>2</sup></b>
<b>effect</b>	969.820	13.122	4.374	8.890	-0.155
<b>Factor</b>	<b>X2<sup>2</sup></b>	<b>X3<sup>2</sup></b>	<b>X1·X2</b>	<b>X1·X3</b>	<b>X2·X3</b>
<b>effect</b>	-0.008	-0.054	-0.035	0.032	-0.019

In order to graphically show the correlation among the response and the factors, we use the MATLAB<sup>®</sup> function RSTool which allow to interactively plot the response (either in presence or in absence of electroporation) as a function of one parameter at a time while letting the remaining two fixed. In Figure 4 we compare the responses with ( $Y_{elp}$ ) and without ( $Y_{nelp}$ ) the electroporation generator in the circuit of Figure 1.

The results in Figure 4 show that there is a linear dependence of the TMV maximum with respect to X1 and X3, whereas it is of quadratic type for X2. These behaviours are evident for the responses obtained either in absence of the electroporation phenomenon ( $Y_{nelp}$  in the upper part of Figure 4) or in presence of it ( $Y_{elp}$  in the lower part of Figure 4).

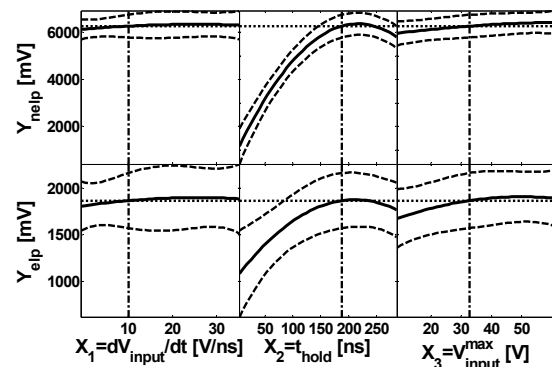

Figure 4: Behaviour of the responses as a function of one parameter at a time while the remaining two are fixed.

Moreover, since the shapes of the curves remain the same in these two cases, it is possible to state that the behaviour is not influenced by the electroporation phenomenon, but it is mainly dictated by the non-linear conductances of the ionic channels, i.e. the common part of the circuit. By looking at the values of the response, it is evident that, according to similar results obtained by other research groups (DeBruin and Krassowska, 1999), the maximum of the TMV is three times greater in the basic HH model than that obtained when electroporation is taken into account. In Figure 5 the resultant maximum of the responses  $Y_{elp}$  is depicted, where we have set  $X1=34.3V/ns$ ,  $X2=120.7ns$ ,  $X3=60V$  corresponding to the Best Parameters Set (BPS= $X1^*, X2^*, X3^*$ ), as previously obtained by the DoE approach. Such a combination gives  $Y_{elp}=1.77V$ . As found also by using DoE, the most influencing factors are  $X3$  and  $X2$  because they give rise to the greater variation of the response.

The effectiveness of the BPS identification procedure based on RSM is checked by evaluating the real TMV peak value in correspondence of the BPS from the circuital model described by the equation system (3). Firstly we note that the time evolutions depicted in Figures 6-7 are characterised by a change of the shape similar to that found by other researchers (Vasilkoski et al., 2006) for similar values of  $t_{hold}$  and  $dv/dt$ . The plots depicted in Figure 6 show the time evolutions of TMV for the BPS (thin continuous line) and for other combinations of the parameters. In particular, the other three curves are obtained for  $X1=X1^*$ ,  $X2$  set to its min value and three different values of  $X3$  (including  $X3^*$ ). We obtain for the BPS the highest actual peak value of TMV equal to 1.65V. Such a value exhibits a small discrepancy of about 7% to the value (1.77V) obtained by means of the RSM. Better accordance may eventually be achieved by adopting a polynomial Response Surface of higher order. We also note that the two solid curves corresponding respectively to BPS (thin line) and that obtained for ( $X1^*, X2_{min}, X3^*$ ) (thick line) overlap in the first part and are characterised by the same peak value, since the applied stress during the rising front, i.e. the main cause influencing the peak, coincides. Moreover, a decrease of  $X3$  determines a sensible decrease in the peak value of TMV.

The effects induced in the response by varying  $X1$  and  $X3$  and keeping constant the pulse duration  $t_{hold}$  to its min value ( $X2_{min}=11ns$ ) can be appreciated by comparing the plots of Figure 6 and 7. In particular, we observe that the same reduction of  $V_{max}$  (from  $X3=60V$  to  $X3=35V$ ) associated to a

reduction of the slew rate (from  $X1=34.3V/ns$  to  $X1=19.9V/ns$ ) does not lead to appreciable differences in the peak value of the TMV, as shown by the two leftmost curves of Figures 6 and 7. On the other side, a reduction in the slew rate ( $X1=5.7V/ns$  in Figure 7) for the lowest level of  $V_{max}$  ( $X3=10V$ ) induces a significant change in either the peak value or the shape of the TMV dynamics.

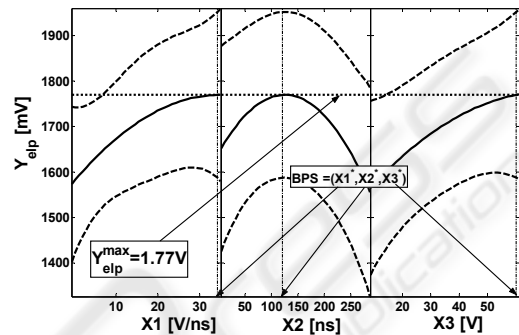

Figure 5: Identification of the BPS for the response  $Y_{elp}$ .

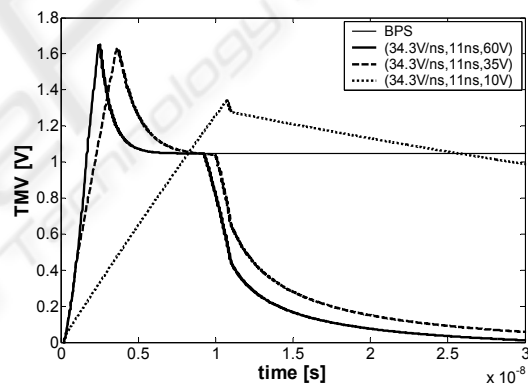

Figure 6: Time evolutions of TMV. BPS=(34.3V/ns, 120.7ns, 60V). The parameters values corresponding to the other curves are reported in the insert.

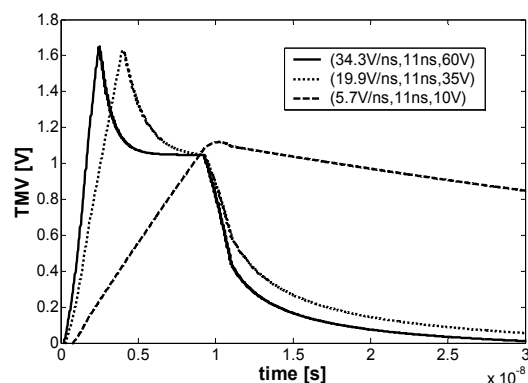

Figure 7: Time evolutions of TMV. The parameters values corresponding to the curves are reported in the insert.

## 5 CONCLUSIONS

A systematic approach based on the combined use of Design of Experiments and Response Surface Methodology has been applied for evaluating the effects induced on the dynamics of the Trans-Membrane Voltage of a biological cell by the characteristics of the applied electric pulses. The proposed methodology is applied to a lumped parameter circuit, subjected to a trapezoidal pulse. The combined use of DoE and RSM allows to reliably identify the parameters set leading to the highest peak value of the TMV. The parameters which show the greatest influence are the max value of the applied pulse and the slew rate whereas the response is almost insensitive to the pulse duration. The proposed approach can be easily extended in order to study the effects of the pulse characteristics on the response of more complex circuit models taking into account also the internal cell structures (nucleus, organelles, etc), such as those describing the cell behaviour to ultrashort, high-intensity pulses for intracellular manipulation.

## ACKNOWLEDGEMENTS

This work has been carried out with the financial support of ex MURST 60% funds of the University of Salerno.

## REFERENCES

- Beebe S.J., Buescher E.S, Schoenbach K.H., "Intracellular effect of ultrashort electrical pulses," *Bioelectromagnetics*, vol. 22, pp.440-448, 2001.
- Bilska, A.O., DeBruin, K.A., Krassowska W. 2000, Theoretical modelling of the effects of shock duration, frequency and strength on the degree of electroporation, *Bioelectrochemistry*, 51, 2000, 133-143.
- Citro, N., Tucci, V. 2006. A detailed analysis of the electrical dynamics of the Hogkin-Huxley cellular model including electroporation. *Proc. of the 4th Int. Workshop on Biological Effects of Electromagnetic Fields*. ISBN/ISSN: 960-233-173-9, Vol. 2: 853-860.
- Citro, N., De Vivo, B., Spagnuolo, G., Tucci, V. (2005), "Range Analysis of Biological Cells Subjected to Pulsed Electric Fields", *Conf. on Electrical Insulation and Dielectric Phenomena*, 10.1109/CEIDP.2005.1560732, pp. 511-514.
- DeBruin, K.A., Krassowska W., 1999. Modelling Electroporation in a Single Cell. I. Effects of Field Strength and Rest Potential. *Biophysical Journal*. 77: 1213-1224.
- Heida, T., Wagenaar, J. B. M., Rutten, W. L. C., Marani, E. 2002. Investigating Membrane Breakdown of Neuronal Cells Exposed to Nonuniform Electric Fields by Finite-Element. Modeling and Experiments. *IEEE Trans. On Biomedical Engineering*. 49-10:1195-1203.
- Hodgkin, A.L., Huxley, A.F. 1952. A quantitative description of membrane current and its application to conduction and excitation in nerve. *Journal of Physiology*. 117: 500-544.
- Hofmann, G. A., Dev, S. B. Dimmer, S., Nanda G. S. 1999. Electroporation therapy: a new approach for the treatment of head and neck cancer, *IEEE Trans. On Biomedical Engineering*. Volume: 46, Issue: 6, 752-759.
- Joshi, R.P., Hu, Q., Schoenbach, K.H. 2004. Modeling studies of cell response to ultrashort, high-intensity electric fields-implications for intracellular manipulation. *IEEE Transactions on Plasma Science*. Vol. 32, issue 4, part II: 1677- 1686.
- Joshi, R.P., Hu, Q., Schoenbach, K.H. 2004. Energy-landscape-model analysis for irreversibility and ist pulse-width dependence in cells subjected to a high-intensity ultrashort electric pulse. *Physical Review E* 69, 051901.
- Koyamada, K., Sakai, K., Itoh, T. 2004. Parameter Optimization Technique Using The Response Surface Methodology. *Proc. of the 26th Annual Int. Conf. of the IEEE EMBS San Francisco, CA, USA* Sept. 1-5.
- Kotnik, T., Miklavcic, D. 2006. Theoretical Evaluation of Voltage Inducement on Internal Membranes of Biological Cells Exposed to Electric Fields. *Biophysical Journal*. 90:480-491.
- Miller, C. E., Henriquez, C.S. 1988. Three Dimensional Finite Element Solution for Biopotential: Erythrocyte in an Applied Field. *IEEE Transaction on Biomedical Engineering*. Vol. 35, No. 9: 712-718.
- Neumann, E., Sowers E., and Jordan C. A., *Electroporation and Electrofusion in Cell Biology*. New York: Plenum, 1989.
- NIST/SEMATECH e-Handbook of Statistical Methods, <http://www.itl.nist.gov/div898/handbook/>
- Sukharev, S. I., et al. 1992,. Electroporation and electrophoretic DNA transfer into cells. The effect of DNA interaction with electropores. *Biophys. J.* 1992, 63(5): 1320-1327.
- Vasilkoski, Z., Esser, A. T., Gowrishankar, T. R., Weaver, J.C. 2006. Membrane electroporation: The absolute rate equation and nanosecond time scale pore creation. 2006. *Physical Review E* 74. 021904.
- Weaver, J.C. 2000, Electroporation of cells and tissues, *IEEE Transactions on Plasma Science*, 2000, Vol. 28, Issue: 1, 24-33.