

TOWARDS A COMPUTER AIDED PEDAGOGICAL ENGINEERING

Aided Production of Pedagogical Devices based on MAETIC Method

Bénédicte Talon

Université Lille Nord de France, LISIC, ULCO, BP 719, 62228 Calais Cedex, Lille, France

Dominique Lecllet

Université de Picardie Jules Verne, MIS, 33 rue Saint Leu, 80039 Amiens Cedex, Amiens, France

Keywords: Computer Aided Pedagogical Engineering, Collaborative Pedagogical Devices, Pedagogical Method, Pedagogical Devices Design Method.

Abstract: The aim of this paper is to present the development of a Computer Aided Pedagogical Engineering studio which provides assistance to any teacher wishing to develop educational devices. The devices, which interest us allow the learning of vocational skills. They have been designed thanks to the pedagogical design method called MAUI. The Information and Communication Technologies will instrument the devices built from the studio. They will be adapted to the educational needs of the teacher. This article presents the context and motivations that led to the development of this studio. It then describes the MAUI design method which helped to design the educational devices based on the MAETIC pedagogical method. It then presents the conceptual architecture of the workshop and the various modules that compose it.

1 INTRODUCTION

The research presented in this paper lies in the domain of vocational training. We focus on a pedagogy which favours collective learning scenarios in project mode. To this end, we have produced educational devices supporting hybrid and at distance education.

Since 2004, a collaboration between the MIS laboratory of University of Picardie (UPJV) and the LISIC Laboratory of University of Littoral Côte d'Opale (ULCO) has allowed to develop, to test and to refine instrumented pedagogical devices. It has also allowed to develop a pedagogical method called MAETIC related to these pedagogical devices. This method favours learning and acquisition of professional knowledge and know-how. These competences are developed in the context of project-based learning in group. The method is implemented through a device called a MAETIC E-suitcase which is deployed since 2005 in various learning domains at the UPJV and ULCO and since 2009 at the University of Djibouti.

The purpose of this paper is to present the development of a Computer Aided Pedagogical Engineering Studio. The objective is to provide assistance to a teacher who wishes to develop MAETIC devices. This studio is built to follow the MAUI design method. The E-suitcases and toolboxes produced thanks to this studio are instrumented by the Information and Communication Technologies (ICT) and are designed to meet the educational needs of teachers.

We want to change practices and procedures adopted by the training centers towards courses having an impact on the social integration of students and that better meet the needs of companies and universities.

To summarize the motivations underlying the development of this studio, the objectives are to:

- Provide a solution for teachers who want to offer their students an alternative to classical pedagogy through the use of project-based pedagogy. We want to offer them an educational approach (MAETIC) that we have developed and tested since 2004.

- Develop a Community of Practice sensitive to active learning that takes the form of projects in-group. In fact, teachers are often constrained by the heaviness, the difficulty and lack of support to design a system that meets their expectations.
- Enhance motivation among students and to some extent, limit the failure and abandonment.
- Provide a repository of professional expertise mobilized during the project. We aim to respond to the issues of professionalization, with the selection by the teacher, of a range of skills, among those referred by their device. We are responding to an ongoing concern of assessing the skills of trainees.
- Offer tools from the Web 2.0 to teachers that are appropriate to their needs and which they control.

The distribution of "turnkey" products based on free and easy-to-use technologies (for a teacher or a student) promote the dissemination of training materials. Thus, after recovery from our respective training in UPJV and ULCO, we would like to expand the recovery of the pedagogical devices on Djiboutian and Morocco territory to test their relevance in this context.

Indeed, Universities of the developing countries are faced with the need to strengthen the professional skills of their students. The search for technical solutions based on ICT to provide quality training at lower cost is a track among others, that institutions must explore.

2 PEDAGOGICAL DEVICES DESIGN METHOD: MAUI

2.1 MAUI Description

The MAUI design method (Lecllet, 2004) is an iterative method. It follows a succession of stages, by gradually refining the specifications, by estimating the remaining solutions and by realizing and integrating modifications until obtaining of a satisfying product. It is an incremental method that allows the progressive adaptation of a system to the met situations.

The method consists of five phases (figure 1):

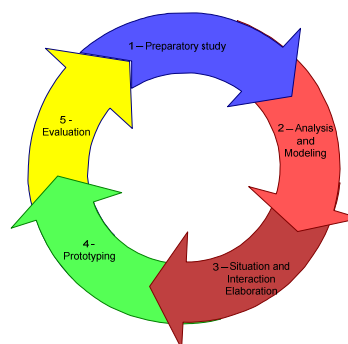

Figure 1: Phases of MAUI.

The Phase 1 - Preparatory Study – consists of defining the device. It produces a document called “teaching requirements”. It consists of four stages:

1. The problem definition: why do you want to develop the teaching device?
2. The context definition: Institution, Place, Level, Discipline, Teaching module, etc.
3. The training definition: aimed competence.
4. The teaching mode definition: at distance, in presence or hybrid.

The Phase 2 - General Design - structures the teaching contents of the future device. It produces a document called “model of teaching”. It consists in an analysis and modeling of teaching sequence, teaching activity, teaching task, teaching resources and so on.

The Phase 3 - Operational Design - describes learning situations and interactions. It produces a document called “operational model of teaching activities”. It is composed of two stages:

1. The choice of tools.
2. The definition of the training scenario: meetings and their durations, activity tasks, relation between teaching resources and type of activities.

The Phase 4 – Prototyping – is the realization of the prototype of the teaching device and the development of the interface by progressive adjustments.

The Phase 5 – Evaluation - tests and evaluates the use of the learning system under real conditions. We find here the participative techniques.

2.2 Maui Application: MAETIC e-Suitcases Design

It is clear that the know-how transmission, in the professional contexts, appears reluctant to theoretical (Potteck, 2003). In this context, new ways of teaching are then considered (Baker, Navarro and Van der Hoek, 2003) (Newman, Daniels and Faulkner 2003), experienced and among these project-based teaching (Thomas 2000). The project method offers an alternative to the transmissive pedagogy.

In active learning through project in group, the teacher plays a facilitating role and accompanies the learner in the process of acquiring knowledge (Goguelin, 1994) (Schneider, 2003). The teacher determines the required work, organizes and directs research information and produces assistance to overcome difficulties in order to maintain the motivation of learners.

Thus, project-based learning allows learners to make sense of their actions that are based on an objective (Sims-Knight and Upchurch, 1998). The motivation to create a product involves a commitment on the part of learners.

Given all these considerations, and in respect of MAUI stages, we have developed, tested and refined, since 2004, instrumented pedagogical devices called E-suitcases (Talon and al, 2006). They all incorporate a pedagogical method named MAETIC (Lecllet and Talon, 2008a). The concept of E-suitcase refers to a device "which conveys to the image of a suitcase, and that is not tied to a fixed place of education" and MAETIC "because this teaching device is the result of an organization and instrumentation of the MAETIC pedagogical method". Finally, we called our educational system dedicated to teachers: MAETIC Toolbox. It refers to tools used by teachers to pilot and control students' actions. The MAETIC method has been published in a book (Lecllet and Talon, 2008b).

3 e-SUITCASES AND THEIR PEDAGOGICAL METHOD

3.1 MAETIC e-Suitcase

The MAETIC e-suitcase is a device which implements a specific organization of the MAETIC method and which is equipped with ICT.

For example, according to MAETIC approach, the teacher must be informed of the progress of the project. The MAETIC method requires each group

to keep a logbook update (this is indicated in the guide in the inserts "work to do for next session"). This logbook aims to describe the life of the project. The teacher and other group members are so informed of the developed deliverables and of project advancement. The logbook should be updated regularly as recommended by the guide. This activity engages students in an action of regular communication and asks them to maintain social ties.

The MAETIC method does not endorse how the logbook must be instrumented. The teacher-designer can quite make the choice to hold this logbook, for example, as a notebook. If they want to orchestrate devices through ICT, teachers have the task to choose the kind of technology that will implement the method. We find teachers who have opted for the blog technology to implement the principles of logging. Others have opted for the Wiki technology.

Similarly, each teacher determines the tools he wants to implement for each of the activities advocated by the MAETIC method: communications, document management, logging, planning, editing, etc. Thus we find teachers who have implemented a CVS for document management while others require a deposit available on the blog in a specific tab. Some have included a chat tool and an awareness tool in the environment, while others advocate a communication by electronic mail.

A number of devices have been designed and developed by teachers since the introduction of MAETIC. Each device is the result of an appropriation of the method by the teachers: a preliminary organization to meet the constraints of the teaching module and instrumentation choices to produce a device that corresponds to their uses.

3.2 MAETIC Pedagogical Method

The pedagogical method describes an approach that favours the implementation of a project-based learning in group. MAETIC is based on five steps (Figure 2) commonly adopted in the project management approaches (Marchat, 2001).

The steps aim to develop activities that will promote the production, in group, according to a project mode, of a "product" requiring solicitation of expertise. The aim is, firstly, to train students in project management. The other aim is to develop skills by implementing a development process of the product in question. The method implies to establish the organization of the group (description of roles) that promotes the development of general skills such as decision, communication, negotiation, etc.

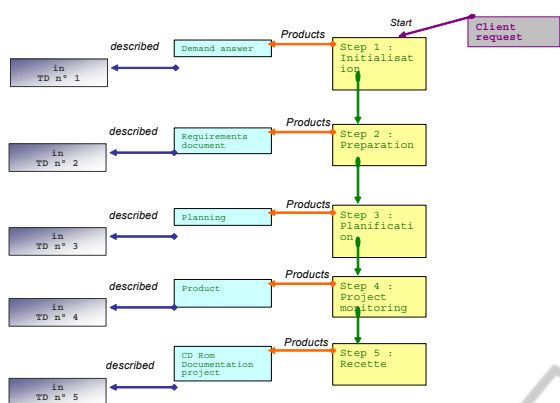

Figure 2: Steps of MAETIC pedagogical method.

Thus, as shown in Figure 2, each step requires one or more deliverable(s) and one or more meeting(s). Step 1 produces the "request response," step 2 the "specifications document", and so on.

Each of these steps is explained in a guide that introduces the student how to carry out the steps. In addition, each step of the guide refers to "technical books" which consist of sheets and templates that are designed to facilitate group work.

4 THE STUDIO

The Computer Aided Pedagogical Engineering studio proposes 5 software components.

4.1 The Assistance Module

The assistance module guides teachers in their MAUI design approach. It allows them to develop an educational device that will meet their choices. By following the steps of MAUI, the module asks the teacher to fill a number of query fields. These actions help to determine the organizational constraints of the module. The organization is governed by different constraints in a specific sociocultural context like time, space, human resources, financial, project establishment, form of instruction (in presence, at distance or hybrid).

The aim of the assistance module (the heart of the studio) is to produce the educational device incorporating all organizational constraints. If a teacher does not use any of the other optional modules, the assistance module will for generate a standard device corresponding to a proposed pattern. The teacher will then dispose of a standard toolbox allowing him/her to monitor the students' E-suitcases. E-suitcases and toolbox will be automatically generated (by the generator module).

A PhD student is currently working on the generation of standard pedagogical devices.

4.2 The Skills Module

The skills module determines the educational activities to implement in order to work the skills that the teacher wishes to develop with his student audience.

We believe that prior knowledge of these skills contributes to the strengthening of educational effectiveness. We agree with the statement of G. Paquette for whom, in the context of training, competency profiles can be used to define learning objectives, to specify the content of a curriculum or materials, to select teaching strategies, media and delivery modes of training (Paquette, 2002a).

In this perspective, knowing the skills developed by students appears to us indispensable. The exercise consists therefore to examine the MAETIC pedagogical method in terms of the skills it builds among students.

The skills module is being finalized. The first phase (Hassan, 2010), aimed to identify the skills developed by MAETIC during its various stages and activities. These skills were modeled using the MOT language (Paquette, 2002b). MOT models were made and translated to form an ontology that has been instrumented with PROTÉGÉ software. The module allows to select skills from a list and shows MAETIC activities to deploy. The next phase is to couple the tool with the assistance module in order to customize the activities within the e-suitcases.

4.3 The Teacher Module

The teacher module facilitates the production of a suitable device with an adapted teaching scenario and suitable technological tools (Rosselle and al, 2010). The aim of the teacher module is to collect teacher needs and wishes (teacher profile and education profile).

The model is reified as a teacher profile. This profile relates to a person who has skills, knowledge, attitudes, personality profile and preferences, especially preferences for ICT tools he/she usually use.

For further information, the reader can consult the teacher model that we have developed in (Rosselle, 2010).

4.4 The Evaluation Module

The evaluation module assists the teacher to conduct the evaluation and reengineering of the device he/she has produced. This module corresponds to phase 5 of MAUI.

We must therefore provide tools and assistance to carry out experiments (assistance in design and development and distribution of questionnaires and interviews). We must facilitate too the reengineering of the educational device. This module initiates a new phase of the spiral design.

This part of the studio has not yet been undertaken and is work phase planned to start in January 2011.

4.4 The Generation Module

The generator module is responsible for generating the technological environment specified by the teacher-designer: the student's e-suitcases and the teacher's toolbox. The environment is based on a template selected from a list: a blog, a Wiki Doku, FaceBook, i-google, a COOLDA type environment, etc. This skeleton has been previously informed by the actions of the designer through the studio (assistance module and its possible profiling via the competence module and the teacher module).

This module is in the design phase. The MODEL research team of LISIC supports a part of this work. It is based on a project for the production of a malleable environment dedicated to collaborative work. These researchers try to create better software environments supporting collaborative activities (Lewandowski and Bourguin, 2006) (Lewandowski and Bourguin, 2005) (Lewandowski, 2006). Their approach has been synthesized into the concept of co-evolution and led to the creation of CoolDA platform.

A key point of their approach is to consider that many tools already exist, and are useful in supporting some activities we are interested in. Thus, the goal is not to create such tools, like a new discussion tool, or a new text processor. Rather, they create an environment that integrates these tools. For example, a group may use in parallel a chat, a web browser, a text processor, and a mailing software. Each of these tools supports a particular activity (online discussion for the chat, etc.) but they do not know each other.

Such an environment has been tested to implement MAETIC activities (Talon and al, 2009). Results have encouraged us to follow and refine this research track.

4.5 The COP Module

This module offers the service of a community of practice. The teacher will be able to draw answers to his/her questions when designing or monitoring of the pedagogical device (Quénu-Joiron and Leclat, 2010).

An experiment is underway in the preamble to the implementation of this module. Through this experiment, we can:

- Check the need for a support tool to assist the teacher during monitoring activities.
- Identify a typology of problems encountered during the implementation of MAETIC projects.
- Collect a corpus of cases
- Analyze the process of problem formulation by a teacher and the different approaches of explanation that can occur between the first formulation and the ranges of solutions provided by the expert teachers.
- Establish the baseline functionalities of the COP module.

Thus, the experiment started in January 2009, is being analysed. The first prototype will be tested as part of the design of MAETIC e-learning devices at the University of Fès in Morocco and at the University of Djibouti.

5 CONCLUSIONS

The CAPE Studio will be able to produce in the next 2 years MAETIC E-suitcases and toolboxes. These MAETIC e-suitcases and toolboxes correspond to tools available from the Web 2.0.

Compared with the French scientific community, there is no research laboratory working on developing such a CAPE incorporating a design approach similar to MAUI. There is no educational device similar to MAETIC e-suitcases. Finally, there is no teaching method similar to MAETIC (Leclat and Talon, 2008).

Compared to the international scientific community, to our knowledge, the main international laboratory working on issues related to ours is that of Gilbert Paquette. However, it should be emphasized that no studio offers the generation of environments based on light tools from the Web 2.0 and modulation offering such an adaptation to the teacher.

REFERENCES

- Baker, A., Navarro, E. O., and Van der Hoek, A., 2003, Problems and Programmers: An Educational Software Engineering Card Game, *Proceedings of the 2003 International Conference on Software Engineering*, Portland, Oregon, 614-619I.
- Hassan, D. M., 2010, Conception et expérimentation d'un laboratoire d'informatique en ligne dans un contexte de pédagogie active de projet : l'environnement eMallette-Lab, PhD thesis, Université de Picardie Jules Verne, 16 juillet 2010, Amiens, France.
- Lecllet, D., 2004, Environnements Interactifs d'Apprentissage dans des contextes professionnels. Des Tuteurs Intelligents aux Systèmes Supports d'Apprentissage à Distance, Habilitation à diriger les recherches, Université de Picardie Jules Verne, Amiens, France.
- Lecllet, D., Talon, B., 2008, Assessment of a Method for Designing E-Learning Devices, *Proceedings of World Conference on Educational Multimedia, Hypermedia and Telecommunications*, ED-MEDIA 2008, AACE/ Springer-Verlag (Ed.), Vienna, Austria, June 30 – July, p 1-8.
- Lecllet D., Talon. B., 2008, Binding the gap between professional context and university: E-suitecase MAETIC for a Real World Experience, *Interactive Computer aided Learning 2008*, ICL 2008, Villach, Austria, September 2008. ISBN: 978-3-89958-353-3.
- Lecllet, D., Talon, B., 2008, La méthode pédagogique MAETIC. Cergy, France: In *Libro Veritas*. ISBN : 978-2-35209-161-5 – 61 pages. http://www.ilv-edition.com/librairie/la_methode_pedagogique_maetic.html
- Lewandowski, A., 2006, Vers de meilleurs supports aux activités coopératives en accord avec la co-évolution — Application au développement logiciel coopératif, PhD thesis, Université du Littoral Côte d'Opale, France.
- Lewandowski, A., Bourguin, G., 2005, Inter-activities management for supporting cooperative software development, *Proceedings of the 14th International Conference on Information Systems Development (ISD'2005)*, Karlstad, Advances in Information Systems Development: Bridging the Gap between Academia and Practice, Nilsson et al. (Eds), ISBN: 0-387-30834-2, Springer Verlag, Vol. 1, pp. 155-167.
- Lewandowski, A., Bourguin, G., 2006, A New Framework for the Support of Software Development Cooperative Activities, *Proceedings of the International Conference on Enterprise Information Systems (ICEIS'06)*, Paphos, Cyprus, May 24-27, pp. 36-43. ISBN: 972-8865-43-0
- Newman, M., Daniels and Faulkner, X., 2003, Open Ended Group Projects a Tool for More Effective Teaching, *ACE2003*, Adelaide, Australia. Vol. 20.
- Paquette, G., 2002a, La modélisation des connaissances et des compétences, pour concevoir et apprendre, Presses de l'Université du Québec, 352 pages
- Paquette, G., 2002b, L'ingénierie pédagogique: pour construire l'apprentissage en réseau, Presses de l'Université du Québec, 431 pages.
- Quénu-Joiron, C., Lecllet, D., 2010, How to Instrument a Community of Practice Dedicated to Project Based Pedagogy tutors: a Solution Based on Case Based Reasoning, *The 10th IEEE conference on advanced learning technologies*, ICALT2010, July 5-7, Sousse, Tunisia.
- Rosselle, M., Lecllet, D., Talon, B., 2010-09-09
- Sims-Knight, J. E., and Upchurch, R. L., 1998, The Acquisition of Expertise in Software Engineering Education, *Proceedings of the 28th Annual Frontiers in Education*, Volume 03, 4-7 November 1998, Tempe, 1302-1307.
- Talon, B., Lecllet, D., Quénu-Joiron, C., 2006, Learning Know-How through a Method using Technologies of Information and Communication and Project-Based Learning: the MAETIC Project, *Proceedings of E-LEARN 2006*, AACE/ Springer-Verlag, Hawaiï, USA, 13-17 october, 2006
- Talon, B., Lecllet, D., 2008, MAUI Experiment: a Method for Designing E-Learning Devices in Project Management Training, *Proceedings of World Conference on Educational Multimedia, Hypermedia and Telecommunications*, ED-MEDIA 2008, AACE/ Springer-Verlag (Ed.), Vienna, Austria, June 30 – July, p 1-8.
- Talon, B., Lecllet, D., Bourguin, G., Lewandowski, A., 2009, Learning Software Testing using a Collaborative Activities Oriented Platform, *The 9th IEEE International Conference on Advanced Learning Technologies*, ICALT2009, 14-18 July, Riga, Latvia.