

# Smart Learning Management System Framework

Yeong-Tae Song<sup>1</sup>, Yuanqiong Wang<sup>1</sup>, Sungchul Hong<sup>1</sup> and Yong-Ik Yoon<sup>2</sup>

<sup>1</sup>Towson University, Dept. of Computer and Information Sciences, Towson, MD, U.S.A.

<sup>2</sup>Sookmyung University, Seoul, Korea

**Keywords:** Smart Learning Management System, Learning Objects, User Profile, Ontology, RDF, Semantic Search.

**Abstract** Thanks to modern networking technologies and advancement of social networks, people in the modern society need more and more information just to be in the game. With such environment, the importance of learning and information sharing cannot be overemphasized. Even though plethora of information is available on various sources such as the web, libraries, and any learning material repositories, if it is not readily available and meets the needs of the user, it may not be utilized. For that, we need a system that can help provide customized information – matches with user's level and interest - to the user. Such system should understand what the user's interests are, what level the user belongs for the topic, and so on. In this paper, we are proposing a framework for smart learning management system (SLMS) that utilizes user profiles and semantically organized learning objects so only the relevant information can be delivered to the user. The SLMS maintains user profiles – continuously updating whenever there is a change – and learning objects that are organized by building ontology. Upon user's request, the system fetches relevant learning materials based on the user's profile. The delivered learning materials are suitable for the user's topic and the level for the requested topic sorted by relevancy ranking.

## 1 INTRODUCTION

We are living in a highly connected society thanks to the modern networking technologies and the Internet. Accessing right information at right time in the society is not only an essential part of everyday lives but also considered a main success factor. Computers are now become a commodity to our work environment as well as to households. In WWW alone, there is more than necessary information available – billions of documents – for any topic. In addition to that, more information is available from other sources such as libraries – digital and traditional - and data repositories – open to public or available only to closed community. To be useful, the available information must be directly related to what users need.

When it comes to e-learning environment, not all documents are eligible for learning. We can classify those eligible for learning as learning objects. When a learner searches for the topic s/he is interested in, those learning objects should be searchable to meet the needs of the learner. The search should be tuned into the learner's intention and aligned with their knowledge level. For that need, the learning objects should be organized into a database using ontology

so that semantic search is possible. For accurate result, the search should be based on learner's profile. Search result then can be ranked by the relevancy by referencing user's profile and the current search topic. It can also be considered as filtering process so the learning management system can recommend directly related learning objects only.

In this paper, we are proposing a smart learning management system framework where user profile is maintained dynamically by keeping track of the changes in the profile. The changes can be either static, typically provided by user, or dynamic, typically provided by some type of agent in the system. Whenever a user is searching for a learning object, the profile is updated automatically to reflect the preference and topic of interest. In the framework, the learning objects are preprocessed – by building ontology - and stored in the learning object repository. The preprocessed learning object information in RDF (Resource Description Framework) can be used for semantic search. After each search, the result can be prioritized and indexed so it can be used for the recommendation to the learners. The rest of the paper is organized as follows:

Section 2 discusses about the related work, section 3 discusses learning profile, section 4 discusses learning objects, section 5 illustrates the smart learning management framework, and section 6 concludes the paper.

## 2 RELATED WORK

There have been several approaches in making intelligent learning management system. One approach is to provide only the relevant learning materials to the learners. Zaina et al., 2010) suggested filtering method in preparing learning objects by referencing user preferences. Ochoa and Duval (Ochoa and Duval, 2006) proposed contextual attention metadata for ranking and recommending learning objects. Another approach is to build ontology for the learning objects. Keleberda (Keleberda et al., 2006) proposed a methodology for building learning object's and learner's ontology using IDEF5 and OWL. The reusability of learning object in multi-granularity was proposed by Meyer et al. (Meyer et al., 2011).

### 2.1 Learner Profile

There are two outstanding learner profile standards: one is the IMS LIP (Learner Information Package) standard and the other is the IEEE PAPI (Personal and Private Information) standard. The PAPI standard focuses on the tracking of learner's learning performance. PAPI's core data structure elements are personal information set, relationship to other users, learner's security credentials, preference, performance, and portfolio (Chatti, Klamma, Quix, & Kensche, 2005; IEEE P1484.2/D8, 2002). LIP is an XML based structured information model. It provides rich structure for learner's features like goal and interests. LIP's meta-data includes time-related data, identification and indexing information, and privacy and data protection information. The LIP's core data structures are identification, leaning goal, QCL (Qualification, certification, and licenses), learning-related activity, transcript, interest, competency, Affiliation, Accessibility (disability), Security key, and relationship (set of relationships between the core components) (IMS, n.d.). In this paper LIP will be used as a main learner profile standard and some features of PAPI (e.g. performance) will be used in the dynamic learner profile.

### 2.2 Applicable e-Learning Metadata Standards

IMS Global Consortium Common Cartridge (IMS GLC, 2011), IEEE Learning Object Metadata (LOM) (IEEE ITSC, 2002), and ADL SCORM (Jesukiewicz, 2009) are the most well-known metadata standards for describing instructional resources in e-learning. The main purpose of these standards is to allow the interoperability for the learning materials over different learning management systems.

**IMS Global Consortium Common Cartridge** (IMS GLC, 2011) defines a set of open standards specified in XML, including a format for exchange of content between systems (Common Cartridge) to interpret what the digital learning content is and how it is organized. It is described in a manifest; a standard for the metadata describing the content in the cartridge (Learning Object Metadata); a standard for test items, tests, and assessment (Question and Test Interoperability) which allows the inclusion of a question bank; a standard for launching and exchanging data with external applications (Basic Learning Tools Interoperability); a controlled vocabulary to designate the intended use of web content in the cartridge; a schema for populating online discussion forums for collaboration among students; and a schema for populating web links.

**IEEE LOM Standard** defines a learning object as any entity -digital or non-digital- that may be used for learning, education or training. Each metadata instance describes relevant characteristics of the learning object to which it applies. The characteristics are grouped in general (learning object as a whole), life cycle (history and current state), meta-metadata (information about the metadata instance itself), educational (educational and pedagogic characteristics), technical (technical requirements and technical characteristics), rights (intellectual property rights and conditions), relation (relationship between the learning objects), annotation (comments on the educational use, when and by whom the comments were created), and classification (in relation to a particular classification system) categories. The LOM data model is a hierarchy of data elements, including aggregate data elements and simple data elements.

**ADL Sharable Content Object Reference Model (SCORM)** (Jesukiewicz, 2009) is a collection and harmonization of specifications and standards that defines the interrelationship of content objects, data models and protocols such that objects are sharable across systems that conform to the same

model. This specification promotes reusability and interoperability of learning content across Learning Management Systems (LMSs).

### 3 LEARNER PROFILE

In the proposed smart learning management system framework, learner profile consists of learner information and dynamic learning profile.

Learner information is constructed by following IMS LIP (IMS, n.d.) that defines core data structures but extended with more detail attributes.

In the competency attribute in the LIP, we have included desired competency levels (expert, good, fair, basic, minimal) in addition to what it defines so the learner can set the learning goal for the desired topic. Accessibility attribute defines learning preferences:

- Cognitive preference: e.g. issue of learning style
- physical preference: e.g. font size
- Technical preferences: e.g. specific computer platform

Dynamic learning profile is defined as:

- Learner's performance: frequency and duration of using learning objects, exam score, etc
- Bookmarks: associated with a topic of interest
- Topics of interest: collected when learners are using the learning management system
- Learner's level for the topic

Dynamic information is collected and stored in the user profile database during the learning process.

### 4 LEARNING OBJECTS

The purpose of learning objects in e-learning environment is to deliver learning contents in digital formats so they can be used in learning management systems. There are numerous learning objects available in many different formats and scattered in many educational organizations or in each individual's personal libraries. For efficient use of learning objects, it must be organized by using descriptive metadata. The learning objects can be categorized by general, technical, and educational. They can also be categorized by the learner's preference such as perception, presentation format, and student participation (Zaina et al., 2010). Since there are numerous learning objects available, it should be possible to reuse those objects systematically when creating new topics. One such

standard is SCORM (sharable content object reference model) and there is an attempt to reuse SCORM compliant learning objects in different granularity (Meyer et al., 2011). In order for those objects to be reusable, they must be stored in so called learning object repositories (LORs). A LOR is a digital archive where users can upload, search and download learning objects. There are some open LORs such as MERLOT (MERLOT, n.d.) and closed LORs – available only to the associated community - such as Ariadne repository (Duval et al., 2001).

Ontology is used for organizing learning objects in this framework. Ontology specifies the conceptualization of a specific domain in terms of concepts, attributes and relationship (Noy & McGuinness, 2001). In general, it defines the vocabulary and the semantic interconnections and some simple rules of inference and logic for some particular topic. It enables the sharing of common understanding of the structure of information among people or software agents and the reuse of domain knowledge. Therefore, it is critical for allowing the representation, processing, sharing and reuse of the knowledge among applications in web-based e-learning systems.

RDF(S) and XML are standards for expressing ontology in order for it to be shared and reused (Ghaleb et al., 2006). OWL (Web Ontology Language) is W3C recommended language for representing ontologies. OWL is a set of XML elements and attributes with well-defined meaning.

RDF is a framework that represents metadata, and a model for representing data about "things on the Web". It includes a set of triples (subject, predicate, object). Alternatively, a RDF model can be represented with a directed labeled graph, or using an XML-based encoding.

RDF Schema (RDFS) defines the vocabulary of an RDF model. It uses basic modeling primitives such as class, subclass-of, property, subproperty-of, domain, range, and type. RDFS provides information about the ways in which we describe our data.

Based on the IEEE LOM standard, we will be focusing on general and technical perspectives of the learning object. Learning object ontology will be used to organize learning objects for easy retrieval.

In our model, specific domain (or learning area) is defined in a content ontology, while the technical aspect of the presentation is presented in a structural ontology. Figure 1 is a snapshot of a sample ontology created using Protégé 4.1 (Stanford, 2012). It illustrates how the learning objects can be

organized. The content ontology is used for describing the domain structure. In addition to the definition of the classes in the ontology, the properties for each class also need to be identified. For example, the difficulty level of the learning object will be defined as five levels from "very easy" to "very difficult" according to the IEEE LOM standard. The relationships among different topics in one domain will also be specified. The structural ontology is used for describing technical details such as types of activities and how the learning materials will be presented. Organizing the materials with these two ontologies make it easier to expand learning materials into other domains. When learning materials related to a new domain are created, only the content ontology needs to be created for the new domain. When the search is conducted, the content ontology will be used to interpret and help identify the relevant learning object in the repository. The structural ontology will then be used to identify relevant presentation of the content (e.g. based on user's profile, a video with caption is needed to present lecture notes).

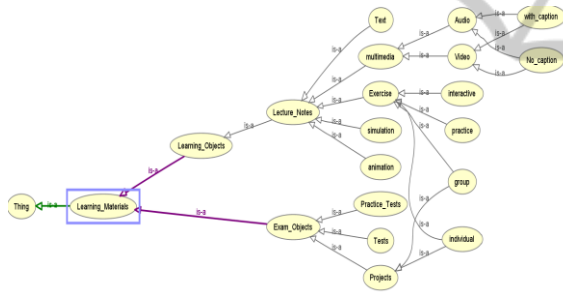

Figure 1: A snapshot of sample structural ontology using Protégé 4.1.

In the figure 2, three nodes are highlighted to represent one sub-node (behavioral model) being related to two super nodes (system modeling and object-oriented analysis and design).

## 5 THE SMART LEARNING MANAGEMENT SYSTEM (SLMS) FRAMEWORK

### 5.1 Dynamic User Profiler

User profile maintains characteristics of the learner, which can be categorized into two groups – static and dynamic. Static information contains learner information defined by IMS LIP such as goals, learning preferences, accessibility, etc. and extended

to include more attributes. Dynamic information includes learning performance, bookmarks, topic of interest, and user level. Dynamic profiler generates user profile dynamically from the user profile database whenever there is a change so the resulting profile can be up to date anytime.

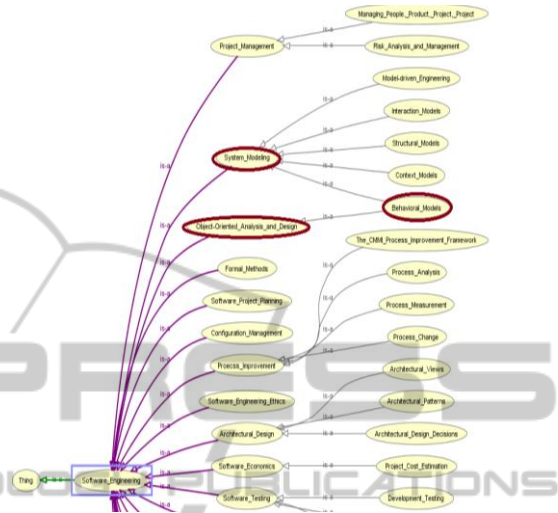

Figure 2: Snapshot of the content ontology on software engineering.

### 5.2 Dynamic User Profile

User profile is an XML document that contains up to date information about the user's learning environment and characteristics of the user. It is dynamically created whenever there is a change or new information about the profile.

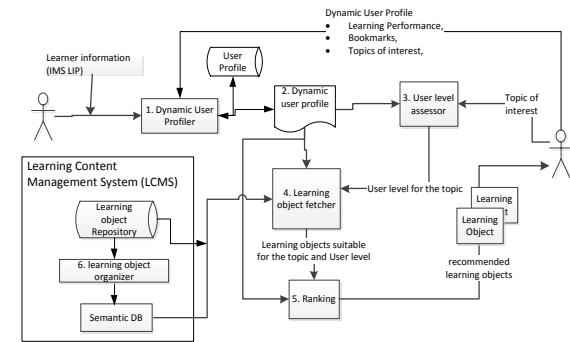

Figure 3: The SLMS Framework.

### 5.3 User Level Assessor

User level on the topic will be determined by user level assessor based on the user profile and the current topic of interest.

### 5.4 Learning Object Fetcher

Learning object fetcher references user’s dynamic profile and searches semantic database that is constructed by the ontology on the learning objects. The Learning Object Fetch Module (LOFM) matches the user’s learning goal which is captured in the learner profiles and the learning objects (LOs). LOs are stored at Learning Object Repository according to the content ontology. The meta-data and the content of these LOs are stored in the form of RDF. The Learning Object Repository has a hierarchical structure T, which can have sub-structures  $T_i$ , where

$$T = \cup_{all i} T_i \tag{1}$$

Each  $T_i$  can be defined by its own sub-structures recursively. The dynamic user profiler (module 1 in Figure 3) generates user learning goal, G, in a hierarchical form. Then the LOFM tries to match G in T. If a sub-structure matches, let’s say it is  $T_k$ , then the module fetches LOs under  $T_k$ . The example of a fetch scenario is shown in the figure 4.

#### Learning Object Indexing

Learning Object Repository indexing has multiple levels: the highest level describes the class hierarchy of an application, e.g. SCORM, the second level describes attributes and content values, and the last level describes the structural indices for the Learning Objects (Chen, Kashyap, & Ghafoor, 2000).

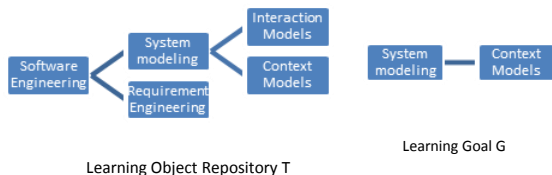

Figure 4: Sample fetch scenario with learning goal and a part of repository structure.

### 5.5 Ranking

The ranking module (module 5 in the figure 3) references dynamic user profile and determines the relevancy of each learning material in the result. The result is sorted by relevancy. Once a Learning Goal is used for learning object (LO) fetching, multiple LOs could be selected. These Learning Objects may exist in different sub-trees, which are related by the content ontology, let’s say sub-tree  $T_k$  and  $T_l$  are fetched, where  $T_k$  and  $T_l$  are the sub-trees of Learning Object Repository T. At this point the ranking module evaluates the level of relevancy

between the learning goal G and fetched LOs ( $T_k$  and  $T_l$ ). If the evaluated relevancy level of  $T_k$  is higher than that of  $T_l$  then  $T_k$  will receive a higher ranking. For example, a learner’s learning goal is “Behavioral System Modeling”. The Learning Object fetcher selects sub-trees for behavioral models under the system modeling and under the Object Oriented Analysis and Design due to the relationship between the OOAD and the behavioral design methodology. Among these two results, the ranking module will evaluate the system modeling as higher relevancy to behavioral modeling over OOAD because of its closer relationship to the learning goal – behavioral system modeling.

### 5.6 Learning Object Organizer

The learning object organizer (module 6 in the figure 3) constructs ontology by referencing learning objects. Through the RDF, learning objects have relations with each other. Section 4.1 discusses how to build the ontology using software engineering example.

The snapshot of the prototype of the smart learning management is in the figure 5. The prototype is named as “Smart e-Learning Using N-Screens” or SELNUNS.

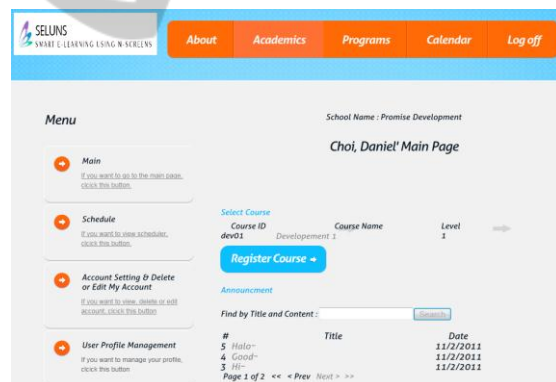

Figure 5: SLMS prototype.

## 6 CONCLUSIONS

Previous literature reported attempts on defining framework for agent based e-learning systems(e.g. Rosmalen et al., 2005; Zaina et al., 2010) However, most of the framework reported did not provide details on issues such as how user profile can be established and maintained, how the LOs can be organized, and how the semantic search can be conducted in order to present LOs that are the most relevant to the learners needs (including content,

learning activities, and presentation styles, etc).

In this paper, we have proposed a framework for smart learning management system. The framework is designed to provide learning materials that is suitable for the user level for the topic and most relevant to the user's interest. To improve the accuracy, we have separated user profile into two parts – static and dynamic, which is an extension of IMS LIP definition. Dynamic profiler maintains up to date information for user profile so the learning object fetcher and the user level assessor can reference them to provide more accurate result to the learner. Learning objects are organized by constructing ontology. Based on RDF description, semantic search for the learning objects can be conducted. The final results are filtered by using relevancy ranking and the filtered result is delivered to the learner as recommended learning objects.

## ACKNOWLEDGEMENTS

This research work is funded by Korea Association of Industry, Academy, and Research Institute (KAIRI).

## REFERENCES

- Chatti, M. A., Klamma, R., Quix, C., & Kensche, D. (2005). LM-DTM: an environment for XML-based, LIP/PAPI-compliant deployment, transformation and matching of learner models. *Fifth IEEE International Conference on Advanced Learning Technologies*, 567-569. Kaosiung, Taiwan.
- Chen, S.-C., Kashyap, R. L., & Ghaffoor, A. (2000). *Semantic models for multimedia database searching and browsing*. Boston, MA: Kluwer Academic Publishers.
- Duval, E., Forte, E., Cardinaels, K., Verhoeven, B., Van Durm, R., Hendriks, K., Forte, M. W., et al. (2001). The Ariadne knowledge pool system. *Communications of the ACM*, 44(5), 72-78.
- Ghaleb, F., Daoud, S., Hasna, A., Alja, J. M., El-seoud, S. A., & El-sofany, H. (2006). E-Learning Model Based On Semantic Web Technology. *International Journal of Computing & Information Sciences*, 4(2), 63-71.
- IEEE P1484.2/D8. (2002). Public and Private Information (PAPI) for Learners. Retrieved from <http://edutools.com/papi/>
- IMS. (n.d.). IMS Learner Information Packaging Information Model Specification. Retrieved March 20, 2012, from <http://www.imsglobal.org/profiles/lipinfo01.html>
- IMS GLC. (2011). IMS GLC Common Cartridge Profile: Overview. Retrieved from [http://www.imsglobal.org/cc/ccv1p2/imsc\\_profilev1p2-Overview.html](http://www.imsglobal.org/cc/ccv1p2/imsc_profilev1p2-Overview.html)
- Jesukiewicz, P. (2009). SCORM 2004 Content Aggregation Model. *Learning*. Retrieved from <http://www.adlnet.gov/capabilities/scorm/scorm-2004-4#tab-resources>
- Keleberda, I., Repka, V., & Biletskiy, Y. (2006). Building Learner's Ontologies to Assist Personalized Search of Learning Objects. In *ICEC'06*, 569-573. Fredericton, Canada.
- MERLOT. (n.d.). MERLOT - Multimedia Educational Resource for Learning and Online Teaching. Retrieved March 20, 2012, from <http://www.merlot.org/merlot/index.htm>
- Meyer, M., Rensing, C., & Steinmetz, R. (2011). Multigranularity reuse of learning resources. *ACM Transactions on Multimedia Computing, Communications, and Applications*, 7(1), 1-23.
- Noy, N. F., & McGuinness, D. L. (2001). Ontology development 101: A guide to creating your first ontology. *Development. Stanford knowledge systems laboratory technical report KSL-01-05 and Stanford medical informatics technical report SMI-2001-0880*. Retrieved from <http://er.uni-koblenz.de/IFI/AGStaab/Teaching/SS09/sw09/Ontology101.pdf>
- Ochoa, X., & Duval, E. (2006). Use of contextualized attention metadata for ranking and recommending learning objects. In *CAMA '06*, 9-15. ACM Press.
- Rosmalen, P. V., Brouns, F., Tattersall, C., Vogten, H., Bruggen, J. V., & Koper, R. (2005). Towards an open framework for adaptive, agent-supported e-learning. *International Journal of Continuing Engineering Education and Life Long Learning*, 15(3), 261-275. Retrieved from <http://dspace.learningnetworks.org/retrieve/94/>
- Stanford. (2012). Protégé. Retrieved from <http://protege.stanford.edu/>
- Zaina, L. A. M., Rodrigues, J. F., & Bressan, G. (2010). An approach to design the student interaction based on the recommendation of e-learning objects. In *SIGDOC'10, the 28th ACM International Conference on Design of Communication*, 223. ACM Press.