

Induction Motor Speed Control using Fuzzy Neural Network Speed Estimation

Tien-Chi Chen and Wei-Chung Wang

Department of Electrical Engineering, Kun Shan University, Tainan, Taiwan

Keywords: Induction Motor, Encoder, Speed Sensorless Control, RFNN, Fuzzy Neural Network Speed Estimation, Steepest Descent Algorithm, Back-propagation Algorithm.

Abstract: The field-oriented control (FOC) of induction motor has high static and dynamic performance. In order to achieve the speed loop feedback control, precise rotor speed information is important for induction motor control. In the past, encoder was widely used to obtain the speed information of induction motor. However, speed sensor would increase the cost of entire system and reduce the system reliability. In addition, for some special applications such as very high speed motor drives, some difficulties are encountered in mounting these speed sensors. The speed sensorless control would overcome these problems. This paper proposes a fuzzy neural network speed estimation for induction motor speed sensorless control. The speed estimation is based on the deduction of rotor flux and estimated rotor flux, which is calculated by fuzzy neural network. The fuzzy neural network includes a four-layer network. The steepest descent algorithm and back-propagation algorithm are used to adjust the parameters of fuzzy neural network in order to minimize the error between the rotor flux and the estimated rotor flux, which is implied to enable precise estimation of the rotor speed.

1 INTRODUCTION

The motor is one of the most important mechanical power sources in electrical machinery industry. The induction motor have applied in many industry (Angelo et al., 2006), which are very economical, rugged and reliable. Furthermore, because of the advances in power electronics and microprocessors, the induction motor applications in speed control have become more and more attractive.

The control scheme is important in order to precisely control the induction motor. The V/f control method was used in induction motor speed control (Perera et al., 2003). However, due to the influence of the stator resistance and the necessary rotor slip to produce torque, its application at low speed is still challenging.

The invention of field-oriented control (FOC) in 1970s can solve the foregoing problems. The FOC which has high static and dynamic performance becomes very popular in recently (Singh et al., 2005); (Consoli et al., 2004). The FOC applied to induction motor drives allow us to perform fast and fully decoupled control of torque and flux.

In modern control techniques of the induction

motor drives, the closed loop speed control system uses shaft encoder to measure motor speed. However, speed sensor has several disadvantages from the viewpoint of drive cost, noise immunity and reliability. From the point of view, as well as for general purpose and low cost drives, speed sensorless control have been published (Kwon et al., 2005). These methods are further classified into the following methodologies such as Kalman filter techniques, model reference adaptive systems and sliding mode method (Zhen and Xu, 1998); (Lascu et al., 2004). The Kalman filtering algorithm dose not contain the feedback signal to train the parameter that would increase the system uncertainty. The model reference adaptive systems speed sensorless methods are mainly affected by motor's parameters which affect the accuracy of the speed estimation then it could spoil the system's stability.

In order to obtain good performance on speed estimation, this paper proposes a speed estimation algorithm based on fuzzy neural network. Up to now, the fuzzy neural network has been applied for many cases, mainly in the controller of converters and drives, but its application in speed estimation is

practically new (Kim et al., 2001). The proposed fuzzy neural network which has feedback signal incorporates a four-layer network including input layer, membership layer, rule layer and output layer. The rotor flux is derived from the motor's dynamic model. The estimated rotor flux is the fuzzy neural network output. The error between the rotor flux and the estimated rotor flux is used as the feedback signal to adjust the parameters of fuzzy neural network through back-propagated method (Chen et al., 2011). This method is to minimize the difference between the rotor flux and the estimated rotor flux, the back-propagation mechanism is easy to derive so that a precise estimation of the rotor speed can track the actual motor speed soon.

The proposed control scheme is implemented in TMS320F2808 DSP. Simulation and experimental results are shown to confirm that the proposed fuzzy neural network speed estimation can provide good performance for induction motor speed control.

2 THE DYNAMIC MODEL OF INDUCTION MOTOR

The dynamic model of the induction motor in the synchronous rotating d-q frame can be expressed as follows (Bose, 1986):

$$\begin{aligned} i_{ds}^e &= -\left(\frac{R_s}{\sigma L_s} + \frac{R_r(1-\sigma)}{\sigma L_r}\right) i_{ds}^e + \omega_e i_{qs}^e + \frac{L_m R_r}{\sigma L_s L_r} \phi_{dr}^e + \frac{\omega_r L_m}{\sigma L_s L_r} \phi_{qr}^e + \frac{v_{ds}^e}{\sigma L_s} \\ i_{qs}^e &= -\omega_e i_{ds}^e - \left(\frac{R_s}{\sigma L_s} + \frac{R_r(1-\sigma)}{\sigma L_r}\right) i_{qs}^e - \frac{\omega_r L_m}{\sigma L_s L_r} \phi_{dr}^e + \frac{L_m R_r}{\sigma L_s L_r} \phi_{qr}^e + \frac{v_{qs}^e}{\sigma L_s} \\ \phi_{dr}^e &= \frac{L_m R_r}{L_r} i_{ds}^e - \frac{R_r}{L_r} \phi_{dr}^e + (\omega_e - \omega_r) \phi_{qr}^e \\ \phi_{qr}^e &= \frac{L_m R_r}{L_r} i_{qs}^e - (\omega_e - \omega_r) \phi_{dr}^e - \frac{R_r}{L_r} \phi_{qr}^e \end{aligned} \quad (1)$$

The torque equation is given as follows:

$$T_e = \frac{3PL_m}{4L_r} (\phi_{dr}^e i_{qs}^e - \phi_{qr}^e i_{ds}^e) = \frac{2}{P} J \frac{d\omega_r}{dt} + B\omega_r + T_L \quad (2)$$

where L_s, L_r, L_m : stator inductance, rotor inductance and mutual inductance, R_s, R_r : stator resistance and rotor resistance, $\sigma = 1 - (L_m^2 / L_s L_r)$, v_{qs}^e, v_{ds}^e : q-axis and d-axis stator voltage in the synchronous rotating frame, i_{qs}^e, i_{ds}^e : q-axis and d-axis stator current in the synchronous rotating frame, ϕ_{qr}^e, ϕ_{dr}^e : q-axis and d-axis rotor flux in the synchronous rotating frame, P : pole number of the induction motor, T_e, T_L : electromagnetic torque and load torque, J, B :

moment of inertial and viscous coefficient of the induction motor, ω_r : rotor angular velocity, ω_e : electrical angular velocity.

3 FUZZY NEURAL NETWORK SPEED ESTIMATION

A fuzzy neural network is employed for induction motor speed estimation. Fig. 1 illustrates the block diagram of proposed speed sensorless estimation using fuzzy neural network. There are two independent fluxes in the proposed method. One is the rotor flux (ϕ_r^e) of the induction motor's dynamic model. The other is the estimated rotor flux ($\hat{\phi}_r^e$) obtain from the fuzzy neural network. The error (\bar{e}) between the two independent fluxes is used to adjust the parameters ($\bar{y}^j, \bar{x}_i^j, \bar{\sigma}_i^j$) of fuzzy neural network by using the back-propagation algorithm such that the estimated rotor flux coincide with the rotor flux, and the estimated speed ($\hat{\omega}_r$) can tracks the actual motor speed (ω_r) precisely.

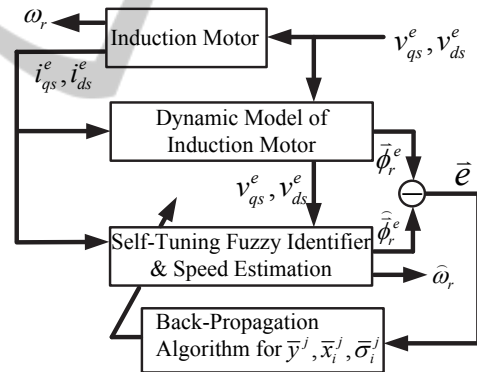

Figure 1: A fuzzy neural network for induction motor speed estimation.

3.1 The Principle of Speed Estimation

Taking some manipulations of the first and third row of (1) yields:

$$\frac{d\phi_{dr}^e}{dt} = \frac{L_r}{L_m} (v_{ds}^e - R_s i_{ds}^e - \sigma L_s \frac{di_{ds}^e}{dt}) + \frac{\sigma L_r L_s \omega_e}{L_m} i_{qs}^e + \omega_e \phi_{qr}^e \quad (3)$$

Taking some algebraic operation of the second and forth rows of equation (1) yields:

$$\frac{d\phi_{qr}^e}{dt} = \frac{L_r}{L_m} (v_{qs}^e - R_s i_{qs}^e - \sigma L_s \frac{di_{qs}^e}{dt}) - \frac{\sigma L_s L_r \omega_e}{L_m} i_{ds}^e - \omega_e \phi_{dr}^e \quad (4)$$

Equations (3) and (4) can be rewritten as the following matrix form of the rotor flux equation:

$$\frac{d\hat{\phi}_r^e}{dt} = \frac{L_r}{L_m} I(\bar{V}_s^e - R_s \bar{I}_s^e - \sigma L_s \frac{d\bar{I}_s^e}{dt}) + \frac{\sigma L_r L_s \omega_e}{L_m} J \bar{I}_s^e + \omega_e J \hat{\phi}_r^e \quad (5)$$

where $\hat{\phi}_r^e = [\hat{\phi}_{dr}^e, \hat{\phi}_{qr}^e]^T$, $\bar{V}_s^e = [v_{ds}^e, v_{qs}^e]^T$, $\bar{I}_s^e = [i_{ds}^e, i_{qs}^e]^T$,
 $I = \begin{bmatrix} 1 & 0 \\ 0 & 1 \end{bmatrix}$, $J = \begin{bmatrix} 0 & -1 \\ 1 & 0 \end{bmatrix}$.

The estimated rotor flux equation is derived from the third and the fourth row of equation (1). Taking some algebraic operation of the third and the fourth rows of equation (1) yields:

$$\frac{d\hat{\phi}_{dr}^e}{dt} = \frac{L_m R_r}{L_r} i_{ds}^e - \frac{R_r}{L_r} \hat{\phi}_{dr}^e + \omega_e \hat{\phi}_{qr}^e - \omega_r \hat{\phi}_{qr}^e \quad (6)$$

$$\frac{d\hat{\phi}_{qr}^e}{dt} = \frac{L_m R_r}{L_r} i_{qs}^e - \omega_e \hat{\phi}_{dr}^e + \omega_r \hat{\phi}_{dr}^e - \frac{R_r}{L_r} \hat{\phi}_{qr}^e \quad (7)$$

Combining equations (6) and (7), the estimated rotor flux equation can be expressed as the following matrix form:

$$\frac{d\hat{\phi}_r^e}{dt} = \left[\frac{-1}{\tau_r} I + (\hat{\omega}_r - \omega_e) J \right] \hat{\phi}_r^e + \frac{L_m}{\tau_r} I \bar{I}_s^e \quad (8)$$

where $\hat{\phi}_r^e = [\hat{\phi}_{dr}^e, \hat{\phi}_{qr}^e]^T$, $\tau_r = L_r / R_r$ is the rotor time constant, $\hat{\omega}_r$ is the estimated rotor speed.

The discrete-time form of equation (8) can be expressed as:

$$\begin{aligned} \hat{\phi}_r^e(k+1) = & (1 - \frac{T}{\tau_r}) I \hat{\phi}_r^e(k) - \omega_e(k) T J \hat{\phi}_r^e(k) \\ & + \hat{\omega}_r(k) T J \hat{\phi}_r^e(k) + \frac{L_m T}{\tau_r} I \bar{I}_s^e(k) \end{aligned} \quad (9)$$

Since the estimated rotor speed $\hat{\omega}_r$ is unknown and may vary with time, the estimation process becomes time varying due to the unknown term ($\hat{\omega}_r(k) T J \hat{\phi}_r^e(k)$) in equation (9). For resolving the estimated problem, the proposed fuzzy neural network consisting of four-layer structure can get over the problem.

The third term of equation (9) is expressed as:

$$\bar{y}_f(k) = \hat{\omega}_r(k) T J \hat{\phi}_r^e(k) \quad (10)$$

where $\bar{y}_f(k) = [y_{f-d}(k) \ y_{f-q}(k)]^T$. By multiplying $\hat{\phi}_r^{eT}$ on the both sides of equation (10), it can be expressed as:

$$\hat{\phi}_r^{eT} \bar{y}_f(k) = \hat{\phi}_r^{eT} \hat{\omega}_r(k) T J \hat{\phi}_r^e(k) \quad (11)$$

Any mismatch between the rotor flux $\hat{\phi}_r^e(k)$ and the estimated flux $\hat{\phi}_r^e(k)$ estimated by the fuzzy

neural network system would automatically produce an error. This error is further used to adjust the parameters of the fuzzy neural network. If $\hat{\phi}_r^e(k)$ is equal to $\hat{\phi}_r^e(k)$, the estimated rotor speed $\hat{\omega}_r$ can be obtained as:

$$\hat{\omega}_r(k) = \frac{\hat{\phi}_r^{eT} \bar{y}_f(k)}{T \|\hat{\phi}_r^e(k)\|^2} \quad (12)$$

In this way, the motor speed can be predicted accurately by the fuzzy neural network speed sensorless estimation.

3.2 Structure of Fuzzy Neural Network

A four-layer fuzzy neural network, as shown in Fig. 2, which includes an input layer, a membership layer, a rule layer and an output layer, is used to implement the fuzzy neural network. The input of the fuzzy neural network is $x_1 = v_{ds}^e, x_2 = v_{qs}^e, x_3 = i_{ds}^e, x_4 = i_{qs}^e$. For every node in the input layer, its output is equal to input. In the membership layer, each node performs a membership function. The Gaussian function is selected as the membership function, it can be described as:

$$\mu_i^j(x_i) = \exp \left[- \left(\frac{x_i - \bar{x}_i^j}{\bar{\sigma}_i^j} \right)^2 \right] \quad (13)$$

where $j=1, \dots, M$, and M is the number of membership function of each input node. In this paper, the value of M is set to 4, \bar{x}_i^j and $\bar{\sigma}_i^j$ are, respectively, the mean and the standard deviation of the Gaussian function.

Each node in the rule layer is denoted by Π , which multiplies the all input signals. The output of rule layer for the j node is expressed as follows:

$$z^j = \prod_{i=1}^4 \exp \left[- \left(\frac{x_i - \bar{x}_i^j}{\bar{\sigma}_i^j} \right)^2 \right] \quad (14)$$

Furthermore, the signal node in the output layer is labelled as Σ , which computes the summation of all input signal and the output of output layer is expressed as follows:

$$y_{id} = \sum_{j=1}^M \bar{y}_f^j z^j \quad (15)$$

where $y_{id} = \hat{\phi}_r^e$.

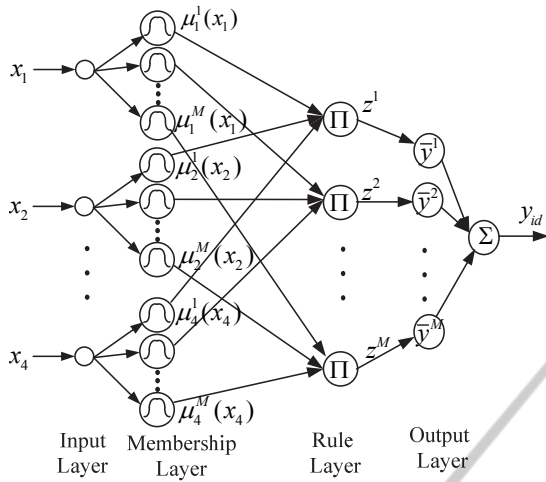

Figure 2: The structure of four-layer fuzzy neural network.

3.3 Training Algorithm for Fuzzy Neural Network

The section describes the online training algorithm of the fuzzy neural network using the back-propagation training algorithm. First, the error function is defined as

$$E_I(k) = \frac{1}{2}(y_{id}(k) - y(k))^2 \quad (16)$$

where $y(k) = \bar{\phi}_e(k)$

The objective is to train the fuzzy neural network such that $E_I(k)$ is minimized. Hence, the identification problem now becomes to train the parameters \bar{y}^j , \bar{x}_i^j and $\bar{\sigma}_i^j$ of fuzzy neural network.

The training method is based on the steepest descent algorithm. The derivation of the training algorithm is described as follows.

(a) Training Algorithm for \bar{y}^j :

In order to train \bar{y}^j , the steepest descent algorithm is expressed as follows:

$$\bar{y}^j(k+1) = \bar{y}^j(k) - \alpha_I \left. \frac{\partial E_I}{\partial \bar{y}^j} \right|_k \quad (17)$$

where α_I is the learning rate of fuzzy identifier.

Using the chain rule for equation (16), it can be expressed as:

$$\frac{\partial E_I}{\partial \bar{y}^j} = (y_{id} - y) \frac{\partial y_{id}}{\partial \bar{y}^j} \quad (18)$$

Substituting (17) into (18), then combining equation (17) and readjusting it, the training algorithm for \bar{y}^j can be expressed as:

$$\bar{y}^j(k+1) = \bar{y}^j(k) - \alpha_I (y_{id}(k) - y(k)) z^j(k) \quad (19)$$

(b) Training Algorithm for \bar{x}_i^j :

For training \bar{x}_i^j , the steepest descent algorithm for \bar{x}_i^j can be expressed as follows:

$$\bar{x}_i^j(k+1) = \bar{x}_i^j(k) - \alpha_I \left. \frac{\partial E_I}{\partial \bar{x}_i^j} \right|_k \quad (20)$$

Applying the chain rule for equation (2.28) to obtain

$$\frac{\partial E_I}{\partial \bar{x}_i^j} = \frac{\partial \left[\frac{1}{2}(y_{id} - y)^2 \right]}{\partial \bar{x}_i^j} = (y_{id} - y) \frac{\partial y_{id}}{\partial z^j} \frac{\partial z^j}{\partial \bar{x}_i^j} \quad (21)$$

Taking partial differential of y_{id} with respect to z^j and partial differential of z^j respect to \bar{x}_i^j by using equation (15) and (14) respectively, then (21) can be expressed as:

$$\frac{\partial E_I}{\partial \bar{x}_i^j} = \frac{2(y_{id} - y) z^j \bar{y}^j (x_i - \bar{x}_i^j)}{\bar{\sigma}_i^j} \quad (22)$$

Substituting (22) into (20), the training algorithm for \bar{x}_i^j can be expressed as:

$$\bar{x}_i^j(k+1) = \bar{x}_i^j(k) - \alpha_I \frac{2(y_{id}(k) - y(k)) \bar{y}^j(k) (x_i(k) - \bar{x}_i^j(k)) z^j(k)}{(\bar{\sigma}_i^j(k))^2} \quad (23)$$

(c) Training Algorithm for $\bar{\sigma}_i^j$:

Using the same method as given above, the training algorithm for $\bar{\sigma}_i^j$ can be expressed as follows:

$$\bar{\sigma}_i^j(k+1) = \bar{\sigma}_i^j(k) - \alpha_I \frac{2(y_{id}(k) - y(k)) \bar{y}^j(k) (x_i(k) - \bar{x}_i^j(k))^2 z^j(k)}{(\bar{\sigma}_i^j(k))^3} \quad (24)$$

The training algorithms given in (19), (23) and (24) perform a back-propagation algorithm for the fuzzy neural network.

4 EXPERIMENTS

In order to demonstrate the feasibility of the control scheme, the experiments are necessary. The parameters of induction motor are: $R_s = 1.1 \Omega$, $R_r = 1.3 \Omega$, $L_s = 0.1452 \text{H}$, $L_r = 0.1456 \text{H}$, $L_m = 0.1363 \text{H}$, $J = 6.8 \times 10^{-4} \text{kg} \cdot \text{m}^2$, $B = 5.15 \times 10^{-4} \text{N} \cdot \text{m} \cdot \text{s/rad}$, $P=2$.

The block diagram of the indirect FOC method for induction motor speed control is shown in Fig. 3.

The block diagram of overall experiment configuration is showed in Fig. 4. The experiment equipment includes the induction motor driver: converter and inverter, isolated circuit, Hall current

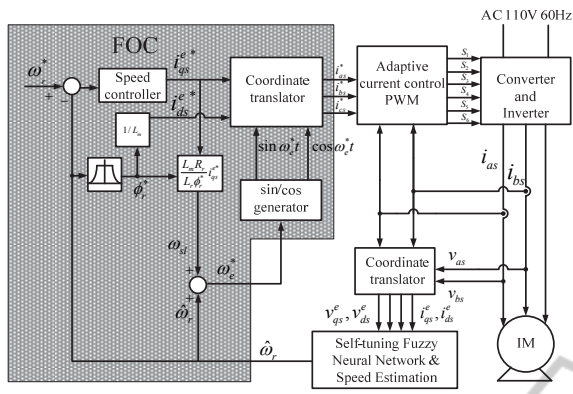

Figure 3: The block diagram of the indirect field-oriented control (FOC) method for induction motor speed control.

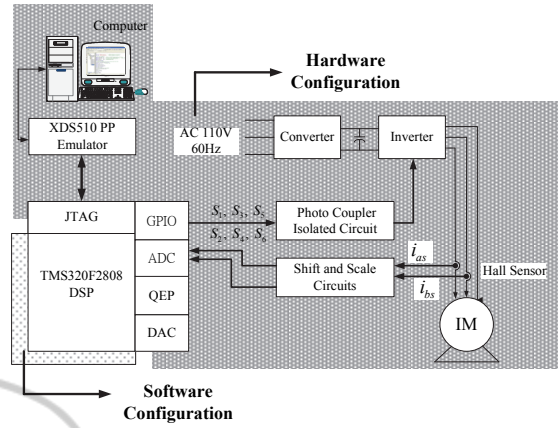

Figure 4: Block diagram of overall experiment configuration.

sensor circuit and DSP TMS320F2808 experiment board. The indirect field-oriented control method is used for induction motor speed control. The proposed control scheme and indirect field-oriented control method are implemented in DSP TMS320F2808 experiment board.

The software control program of experiment includes the adaptive current PWM control, fuzzy neural network speed sensorless estimation, speed controller and sin/cos generator. All of the detailed actions will be described as the flowchart in Fig. 5.

The experimental results of the proposed algorithm are showed in Fig. 6. The actual motor speed response and estimated motor speed response for a speed command of 500 rpm are shown in Figures 6(a) and 6(b) respectively. The speed error between the actual motor speed and the estimated motor speed is shown in Fig. 6(c). The actual d-axis rotor flux and estimated d-axis rotor flux are shown in Figures 6(d) and 6(e) respectively. The d-axis rotor flux error between the actual d-axis rotor flux and estimated d-axis rotor flux is shown in Fig. 6(f).

According to Figs. 6(a) and 6(b), the actual motor speed has a good transient response and the estimated motor speed can track the actual motor speed quickly. Figure 6(c) shows that the speed error decays very soon and the speed error is very slight in steady state. According to Figs. 6(d) to 6(f), the estimated d-axis rotor flux can track the actual d-axis rotor flux quickly. The d-axis rotor flux error is very slight in steady state. This experimental results show that the proposed algorithm has fairly good performance, which is similar to the simulation results.

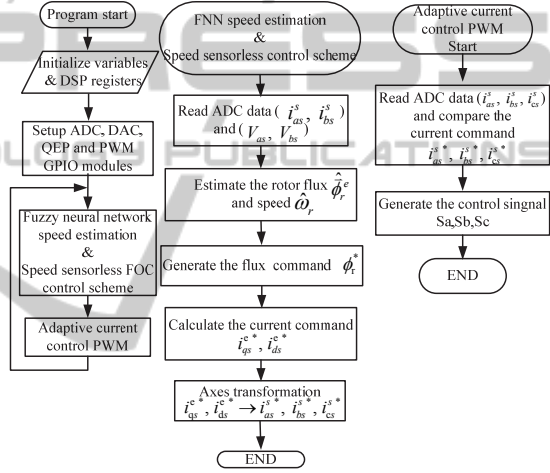

Figure 5: The software procedures of the control algorithm for the proposed scheme.

5 CONCLUSIONS

The main purpose of this paper is to develop a fuzzy neural network speed estimation for the induction motor speed control. The experiment results proved that the proposed fuzzy neural network speed estimation is practical and the performance is great. By using TMS320F2808 experiment board and motor drivers to control induction motor, the performance of fuzzy neural network speed estimation for the induction motor speed control has great effect.

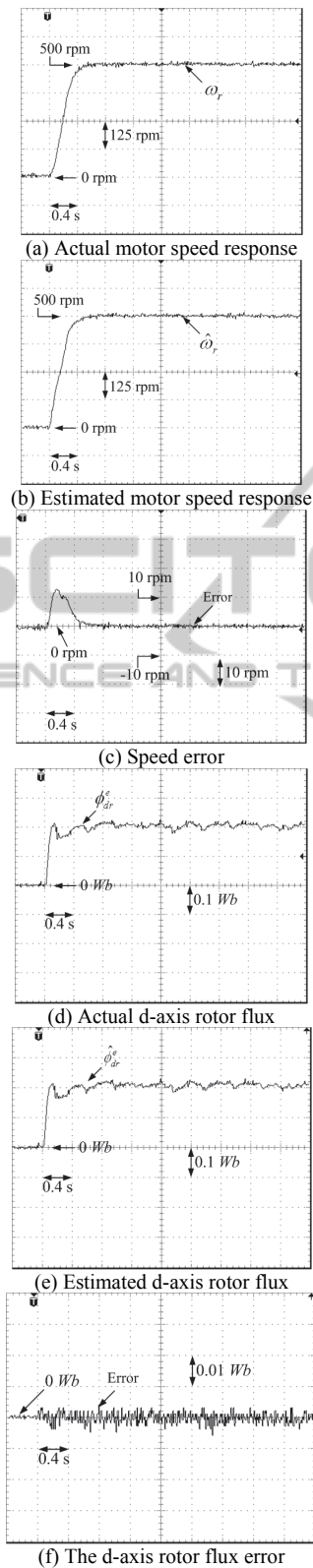

Figure 6: Experimental results for speed command of 500 rpm.

ACKNOWLEDGEMENTS

The authors would like to express their appreciation to NSC for supporting under contact NSC 100-2218-E-168 -004.

REFERENCES

- Angelo, C. D., Bossio, G., Solsona, J., Garcia, G. O., Valla, M. I., 2006. Mechanical Sensorless Speed Control of Permanent-Magnet AC motors Driving an Unknown Load. *IEEE Transactions on Industrial Electronics*, vol. 53, no. 2, pp. 406-414.
- Perera, P. D. C., Blaabjerg, F., Pedersen, J. K., Thogersen, P., 2003. A Sensorless Stable V/f Control Method for Permanent-Magnet Synchronous Motor Drives. *IEEE Transactions on Industry Applications*, vol. 39, no. 3, pp. 783-791.
- Singh, G. K., Singh, D. K. P., Nam, K., Lim, S. K., 2005. A Simple Indirect Field-Oriented Control Scheme for Multiconverter-Fed Induction Motor. *IEEE Transactions on Industrial Electronics*, vol. 52, no. 6, pp. 1653-1659.
- Consoli, A., Scarcella, G., Testa, A., 2004. Slip-Frequency Detection for Indirect Field-Oriented Control Drives. *IEEE Transactions on Industry Applications*, vol. 40, no. 1, pp. 194-201.
- Kwon, T. S., Shin, M. H., Hyun, D. S., 2005. Speed Sensorless Stator Flux-Oriented Control of Induction Motor in the Field Weakening Region Using Luenberger Observer. *IEEE Transactions on Power Electronics*, vol. 20, no. 4, pp. 864-869.
- Zhen, L., Xu, L., 1998. Sensorless Field Orientation Control of Induction Machines Based on a Mutual MRAS Scheme. *IEEE Transactions on Industrial Electronics*, vol. 45, no. 5, pp. 824-831.
- Lascu, C., Boldea, I., Blaabjerg, F., 2004. Direct Torque Control of Sensorless Induction Motor Drives: a Sliding-Mode Approach. *IEEE Transactions on Industry Applications*, Vol. 40, No. 2, pp. 582-590.
- Kim, S. H., Park, T. S., Yoo, J. Y., Park, G. T., 2001. Speed-Sensorless Vector Control of an Induction Motor Using Neural Network Speed Estimation," *IEEE Transaction on Industrial Electronics*, vol. 48, no. 3, pp. 609-614.
- Chen, T. C., Ren T. J., Lou, Y. W., 2011. Design of recurrent fuzzy neural network and general regression neural network controller for traveling-wave ultrasonic motor. *International Conference on Neural Computation Theory and Applications (NCTA2011)*, Paris, France, Oct. 24-26.
- Bose, B. K., 1986. *Power Electronics and Ac Drives*, Prentice-Hall, Englewood Cliffs.