

# Generalized Net Model of the Methodology for Analysis of the Creditworthiness and Evaluation of Credit Risk in SMEs Financing

George L. Shahpazov<sup>1</sup>, Lyubka A. Doukovska<sup>1</sup> and Krassimir T. Atanassov<sup>2</sup>

<sup>1</sup>*Institute of Information and Communication Technologies, Bulgarian Academy of Sciences,  
Acad. G. Bonchev str., bl. 2, 1113 Sofia, Bulgaria*

<sup>2</sup>*Institute of Biophysics and Biomedical Engineering, Acad. G. Bonchev str., bl. 105, 1113 Sofia, Bulgaria  
atlhemus@abv.bg, doukovska@iit.bas.bg, krat@bas.bg*

**Keywords:** Generalized Net Model, Small and Medium-Sized Enterprises (SMEs), Credit Risk, Creditworthiness.

**Abstract:** The launch of the new programming period of the EU in 2014 will lead to many changes in the way the EU budget is funded. The European Commission is considering various ways to generate their own income to make it more independent of the Member States. Unfortunately the consequences of the reforms might have negative influence to European and in particular to the Bulgarian economy and especially for SMEs. The effective results in these conditions are to ensure financial resources for SMEs beneficiaries - increasing the amount of advance payments, creating additional financial instruments. Prior to SMEs financing, a methodology for analysis of creditworthiness and credit risk assessment procedures are applied. The aim of the methodology is to contribute and establish an unified and systematic approach to analyzing and assessing credit risk, which is to lead to a more thorough and objective assessment of the credit and minimize the risk undertaken by the financial institution. The system of credit risk assessment is a collaboration of estimates of the specified indicators. The final conclusion of the process should result into a motivated standpoint, based on which, a decision on further conduct of the Bank towards the loan request will be made (guarantees and other commitments, bearing credit risk), along with periodic risk assessment procedure on already granted loans. In this paper is provided an analysis using the Generalized Nets. They are used as a tool for modelling of different processes in industries and medicine. In the present paper, an application of these nets apparatus for assistive technology and the advantages of using such model, for SMEs financial support mechanism are discussed.

## 1 INTRODUCTION

Considering the harder economic conditions, to which SME's are exposed, the attitude to external financing changes. The research of the sector show that 10 years ago about 7% of enterprises utilized investment loans, 17% had access to working capital funds, and 67% didn't have any access to financing. The aggressive development of banking system along with EU structured funds, significantly increased the accession of SME's to venture funding. From year 2010 onwards, about 55% of companies are able to reach financing of any type.

In 2010 most popular sources of financing between SME's was own resources (about 42%), illegitimate financing from friends and relatives (close to 17%), and at last EU funds and Bank financing (near 30%). A year earlier above 50% of companies are financed with own equity.

Limitations and obstacles in financing occur mainly due to the reduced investment intentions of SME's within the last few years. Main reasons for it are lack of economic stability within the country and EU, along with gradual increase of intercompany leverage. The figures show that, intercompany debt over the past 3 years has gone up over 100%. At present time about 83% of all SME's have uncollected receivables (Bulgarian Industrial Association).

One third of all investments made by SME's are into new equipment and machinery (about 35%), re qualification, training and advertisement is the second investment direction (29%), development of present and design of additional newer products (22%), introduction of systems for intercompany management processes (9%).

Alternative ways of raising funds by SME's are via leasing schemes, where at present about 32% of

SME's are able to reach their investment goals, whereas couple of years earlier the figure is close to 45%.

Due to worsen economic environment and interbanking debt, weaker turnover and profit results, most SME's are unable to rely on own resources. This is valid to such an extent that the financing with own funds has decreased 10 times and in spite of the difficulties, concerning the receipt of a bank loan, it has turned into the most preferred source of funds.

The most popular source of financing among commercial banks and leasing companies is public procurement. Statistics show that about 15% of SME's take advantage of public procurement. Raising funds via government programs was used by 2.9% of the companies, and access to financing via programs of non-government organizations has a share of 2%. Financing via EU structured funds had an insignificant portion (1.6%) up until few years ago. Nowadays the percentage has increased considerably and 45% of SME's is making efforts to receive the embedded financing and grant schemes, (Bulgarian Small and Medium Enterprise Promotion Agency).

Regardless of the above mentioned statistics there hasn't been any considerable changes in regards to the specific difficulties, with which SME are confronted upon the receipt of a bank loan. Most of which they encounter are:

- Considerable interest rates and requirements for sufficient loan collateral. Often companies do not dispose with the necessary real estates, and the interest rates are close to the profitability of their assets.
- Lacking or insufficient credit history (valid to an even greater extent for the new companies). The reason for this often is the concealing of tax, despite the decrease in the tax and social security burden in the last years.
- The relatively low economic and legal general knowledge of the owners of SMEs.
- Incapacity for the preparation of a long-term plan for the development of business. This is the result of the unstable economic environment, as well as of the incapacity of SMEs to prepare reliable long-term financial forecasts.
- High fees, "hidden" interest and the heavy paperwork, associated with loan granting/project financing.
- Requirements for minimum equity and minimum turnover.

## 2 SHORT REMARKS ON GENERALIZED NETS

Generalized Nets (GN) (Atanassov, 1991, Atanassov, 2007) are extensions of Petri nets and other modifications of them. They are tools intended for the detailed modelling of parallel processes.

A GN is a collection of *transitions* and *places* ordered according to some rules (see Figure 1). The places are marked by circles. The set of places to the left of the vertical line (the transition) are called *input places*, and those to the right are called *output places*. For each transition, there is an index matrix with elements called *predicates*. Some GN-places contain *tokens* – dynamic elements entering the net with initial characteristics and getting new ones while moving within the net. Tokens proceed from an input to an output place of the transition if the predicate corresponding to this pair of places in the index matrix is evaluated as "true". Every token has its own identifier and collects its own history that could influence the development of the whole process modelled by the GNs.

Two time-moments are specified for the GNs: for the beginning and the end of functioning, respectively.

A GN can have only a part of its components. In this case, it is called *reduced GN*. Here, we shall give the formal definition of a reduced GN without temporal components, place and arc capacities, and token, place and transition priorities.

Formally, every transition in the used below reduced GN is described by a three-tuple:

$$Z = \langle L', L'', r \rangle \quad (1)$$

where:

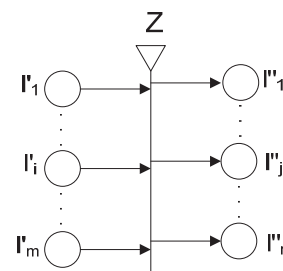

Figure 1: A GN transition.

- (a)  $L'$  and  $L''$  are finite, non-empty sets of places (the transition's input and output places, respectively), for the transition these are:

$$L' = \{l'_1, l'_2, \dots, l'_m\} \text{ and } L'' = \{l''_1, l''_2, \dots, l''_n\};$$

- (b)  $r$  is the transition's *condition* determining which tokens will pass (or *transfer*) from the transition's inputs to its outputs; it has the form of an Index Matrix (IM):

$$r = \begin{array}{c|cccc} & l''_1 & \dots & l''_j & \dots & l''_n \\ \hline l'_1 & & & & & \\ \dots & & & r_{i,j} & & \\ l'_i & (r_{i,j} - \text{predicate}) & & & & \\ \dots & (1 \leq i \leq m, 1 \leq j \leq n) & & & & \\ l'_m & & & & & \end{array}$$

where  $r_{i,j}$  is the predicate that corresponds to the  $i^{\text{th}}$  input and  $j^{\text{th}}$  output place.

When its truth value is "true", a token from the  $i^{\text{th}}$  input place transfers to the  $j^{\text{th}}$  output place; otherwise, this is not possible.

The ordered four-tuple:

$$E = \langle A, K, X, \Phi \rangle \tag{2}$$

is called a *reduced Generalized Net* if:

- (a)  $A$  is the set of transitions;
- (b)  $K$  is the set of the GN's tokens;
- (c)  $X$  is the set of all initial characteristics which the tokens can obtain on entering the net;
- (d)  $\Phi$  is the characteristic function that assigns new characteristics to every token when it makes the transfer from an input to an output place of a given transition.

Many operations (e.g., union, intersection and others), relations (e.g., inclusion, coincidence and others) and operators are defined over the GNs. Operators change the GN-forms, the strategies of token transfer and other. There are six types: global, local, hierarchical, reducing, extending and dynamic operators.

### 3 GENERALIZED NET MODEL

A GN model is described in In this paper will be used GN shown on Figure 2. Five types of tokens move in this GN.

The tokens from the first type are  $\alpha_1$  and  $\alpha_2$ , and they represent bank-administrators. The tokens have the initial and current characteristics: "Credit specialist at branch level" in place  $l_8$  and "Experts at Headquarters level" in place  $l_{15}$ .

The tokens from the second type are the  $\varphi$ -tokens that permanently enter place  $l_1$  with initial characteristic "Potential SME Borrower".

The tokens from the third type are  $\chi_1, \chi_2$  and  $\chi_3$ , representing Bank management. They have the initial and current characteristics: "Credit Council" in place  $l_{18}$ , "Management Board" in place  $l_{21}$  and "Supervisory Board" in place  $l_{24}$ .

In some time-moments, some token  $\varphi$  will split to the original token  $\varphi$  and a token  $\pi$ , while some  $\alpha$ -token and the  $\chi_3$ -token will split to the original  $\alpha$ - or  $\chi_3$ -token and a  $\beta$ -token. These new types of tokens will be discussed below.

$$Z_1 = \langle \{l_1, l_4, l_{13}\}, \{l_2, l_3, l_4\}, r_1 \rangle \tag{3}$$

$$r_1 = \begin{array}{c|ccc} & l_2 & l_3 & l_4 \\ \hline l_1 & false & false & true \\ l_4 & W_{4,2} & W_{4,3} & true \\ l_{13} & false & false & true \end{array},$$

where:

$W_{4,2}$  = "There is a SME client that has prepared a project",

$W_{4,3}$  = "There is an answer from the SME client to a question from the credit specialist at branch level".

Token  $\varphi$  enters place  $l_4$  without a new characteristic.

Token  $\beta_4$  enters place  $l_4$  and unites with token  $\varphi$ , staying there.

If  $W_{4,2} = true$ , then token  $\varphi$  splits to the original token  $\varphi$  and token  $\pi$ . The second one enters place  $l_2$  and there it obtains the characteristic "Loan application, based upon a prepared project". If  $W_{4,3} = true$ , then token  $\varphi$  splits to the original token  $\varphi$  and token  $\beta_1$ . The second one enters place  $l_3$  and there it obtains the characteristic "Requested additional information in regards to submitted project". This token is generated in a result of token  $\beta_4$  that enters place  $l_4$ .

$$Z_2 = \langle \{l_2, l_5, l_8, l_{14}\}, \{l_5, l_6, l_7, l_8\}, r_2 \rangle \tag{4}$$

$$r_2 = \begin{array}{c|cccc} & l_5 & l_6 & l_7 & l_8 \\ \hline l_2 & true & false & false & false \\ l_5 & W_{5,5} & W_{5,6} & W_{5,7} & false \\ l_8 & false & false & W_{8,7} & true \\ l_{14} & false & false & false & true \end{array},$$

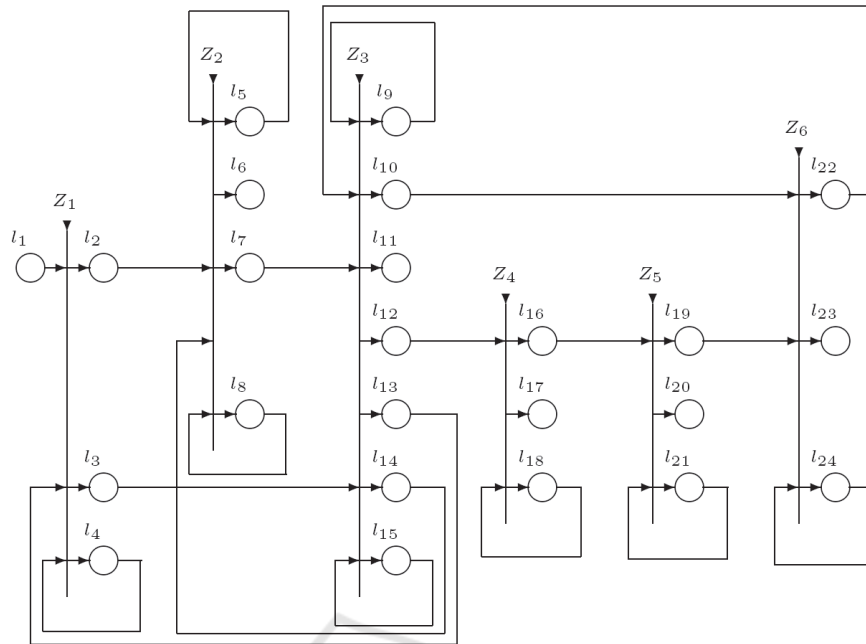

Figure 2: Generalized net model.

where:

$W_{5,5}$  = „By the moment, there is not a solution for the project”,

$W_{5,6}$  = “Project rejected at first level (at branch level)”,

$W_{5,7}$  = “Project accepted at branch level, sent to Headquarters for further detailed research”,

$W_{8,7}$  = “There is an answer of a question initiated by Headquarters experts in regards to the submitted project”.

Token  $\pi$  enters place  $l_5$  without any new characteristic. Token  $\beta_5$  enters place  $l_8$  and unites with token  $\alpha_1$ .

When  $W_{5,5} = true$ , token  $\pi$  continues to stay in place  $l_5$  without a new characteristic. When  $W_{5,6} = true$ , token  $\pi$  enters place  $l_6$  with a characteristic “Project rejected (due to specific motives)”. When  $W_{5,7} = true$ , token  $\pi$  enters place  $l_7$  with a characteristic “Project accepted (due to specific motives)”. If  $W_{8,7} = true$ , then token  $\alpha_1$  splits to the original token  $\alpha_1$  and token  $\beta_2$ . The second one enters place  $l_7$  and there, it obtains the characteristic “Answer from branch level”.

$$Z_3 = \langle \{l_3, l_7, l_9, l_{15}l_{22}\}, \{l_9, l_{10}, l_{11}, l_{12}, l_{13}, l_{14}, l_{15}\}, r_3 \rangle \quad (5)$$

	$l_9$	$l_{10}$	$l_{11}$	$l_{12}$	$l_{13}$	$l_{14}$	$l_{15}$
$r_3$	false	false	false	false	false	false	true
$l_3$	$W_{7,9}$	false	false	false	false	false	$W_{7,15}$
$l_7$	$W_{9,9}$	false	$W_{9,11}$	$W_{9,12}$	false	false	false
$l_9$	$W_{9,9}$	false	$W_{9,11}$	$W_{9,12}$	false	false	false
$l_{15}$	false	$W_{15,10}$	false	false	$W_{15,13}$	$W_{15,14}$	true
$l_{22}$	false	false	false	false	false	false	true

where:

$W_{7,9}$  = “The current token is from  $\pi$ -type”,

$W_{7,15}$  = “The current token is from  $\beta_5$ -type”,

$W_{9,9}$  = „By the moment, there is not a solution for the project”,

$W_{9,11}$  = “Rejected at Headquarters level”,

$W_{9,12}$  = “Accepted and prepared for loan granting”,

$W_{15,10}$  = “An inquiry is initiated and addressed to the Supervisory Board”,

$W_{15,13}$  = “An inquiry is initiated and addressed to the SME Client-borrower”,

$W_{15,14}$  = “An inquiry is initiated and addressed to branch level”.

Token  $\beta_1$  enters place  $l_{15}$  and unites with token  $\alpha_2$ .

When  $W_{7,9} = true$ , token  $\pi$  enters place  $l_9$  without a new characteristic.

When  $W_{9,15} = true$ , token  $\beta_2$  enters place  $l_{15}$  and unites with token  $\alpha_2$ , that obtains the above mentioned current characteristic.

When  $W_{9,9} = true$ , token  $\pi$  continues to stay in place  $l_9$  without a new characteristic.

When  $W_{9,11} = true$ , token  $\pi$  enters place  $l_{11}$  with a characteristic “Project rejected at Headquarters level (due to specific motives)”.

When  $W_{9,12} = true$ , token  $\pi$  enters place  $l_{12}$  with a characteristic “Project accepted at Headquarters level (due to specific motives)”.

When  $W_{15,10} = true$ , token  $\alpha_2$  splits to the original token  $\alpha_2$  and token  $\beta_3$ . The second one enters place  $l_{10}$  and there, it obtains the characteristic “An inquiry is addressed to the Supervisory Board for specific project” or “An answer of Head quarters level to the Supervisory Board”

When  $W_{15,13} = true$ , token  $\alpha_2$  splits to the original token  $\alpha_2$  and token  $\beta_4$ . The second one enters place  $l_{13}$  and there, it obtains the characteristic “An inquiry is addressed to the SME Client-borrower in regards to a specific detail of the project”.

When  $W_{15,14} = true$ , token  $\alpha_2$  splits to the original token  $\alpha_2$  and token  $\beta_5$ . The second one enters place  $l_{14}$  and there, it obtains the characteristic “An inquiry is addressed to Branch level in regards to specific details of the project”.

$$Z_4 = \langle \{l_{12}, l_{18}\}, \{l_{16}, l_{17}, l_{18}\}, r_4 \rangle \quad (6)$$

$$r_4 = \begin{array}{c|ccc} & l_{16} & l_{17} & l_{18} \\ \hline l_{12} & W_{12,16} & W_{12,17} & true \\ l_{18} & false & false & W_{18,18} \end{array}$$

where:

$W_{12,16} =$  “There is a positive decision by Credit council in regards to specific project”,

$W_{12,17} =$  “There is a negative decision by Credit council in regards to specific project”,

$W_{18,18} =$  “There is a token in place  $l_{12}$ ”.

When  $W_{12,16} = true$ , token  $\pi$  enters place  $l_{16}$  with a characteristic “The project is voted and accepted for financing by the Credit council under the original or new updated parameters”.

When  $W_{12,17} = true$ , token  $\pi$  enters place  $l_{17}$  without any characteristic.

$$Z_5 = \langle \{l_{16}, l_{21}\}, \{l_{19}, l_{20}, l_{21}\}, r_5 \rangle \quad (7)$$

$$r_5 = \begin{array}{c|ccc} & l_{19} & l_{20} & l_{21} \\ \hline l_{16} & W_{16,19} & W_{16,20} & true \\ l_{21} & false & false & W_{21,21} \end{array}$$

where:

$W_{16,19} =$  “The Project receives affirmative decision when voted by Management Board”,

$W_{16,20} =$  “The Project receives negative decision when voted by Management Board”,

$W_{21,21} =$  “There is a token in place  $l_{16}$ ”.

When  $W_{16,19} = true$ , token  $\pi$  enters place  $l_{19}$  with a characteristic “The project is voted and accepted for financing by the Management Board under the original or new updated parameters”.

When  $W_{16,20} = true$ , token  $\pi$  enters place  $l_{20}$  without any characteristic.

$$Z_6 = \langle \{l_{10}, l_{19}, l_{24}\}, \{l_{22}, l_{23}, l_{24}\}, r_6 \rangle \quad (8)$$

$$r_6 = \begin{array}{c|ccc} & l_{22} & l_{23} & l_{24} \\ \hline l_{10} & false & false & true \\ l_{19} & false & W_{19,23} & false \\ l_{24} & W_{24,22} & false & W_{24,24} \end{array}$$

where:

$W_{19,23} =$  “Final decision by Supervisory Board”,  
 $W_{24,22} =$  “There is an answer of the Supervisory Board to the Management Board level or there is an answer of the Supervisory Board to a question from the Credit council”,

$W_{24,24} =$  “There is a token in place  $l_{19}$ ”.

Token  $\beta_3$  enters place  $l_{24}$  and unites with token  $\chi_3$ .

When  $W_{19,23} = true$ , token  $\pi$  enters place  $l_{23}$  with a characteristic “Final decision (positive or negative) of the Supervisory Board about the project”.

When  $W_{24,22} = true$ , token  $\chi_3$  splits to two tokens – the original token  $\chi_3$  and token  $\beta_6$  that obtains the characteristic “Answer of the Supervisory Board”.

## 4 CONCLUSIONS

The so constructed GN model describes the most important steps of the process of evaluation of a business project proposal intended for financing. In a next research, the authors plan to elaborate the model in the aspect related to the process of decision making within the frames of the bank administration.

First, the model can be used for real-time control of the processes, flowing in a particular bank. If this is the case, the databases of the model will correspond to the real databases of that bank, and the process of adding new characteristics of the respective GN-tokens will correspond to the process of inputting new information in the bank's databases. The tokens, representing the bank's clients, will have

as initial characteristics their specific parameters and with their real project proposals intended for financing. The movement of these real projects will be observed and information for the current status of each of them can be obtained from the model. Practically, the GN-model will synchronize the real processes, related to the above described procedure.

Second, it can be a tool for prognostics of different situations, related to the modeled processes, for example in a given moment of time, a large number of projects may be submitted, and these have to be evaluated in parallel or compete for a limited amount of funding.

Third, on the basis of the model, some changes of the process of evaluation can be simulated and the results can be used for searching the optimal scheduling of the separate steps of this process.

## ACKNOWLEDGEMENTS

The research work reported in the paper is partly supported by the project AComIn “Advanced Computing for Innovation”, grant 316087, funded by the FP7 Capacity Programme (Research Potential of Convergence Regions) and partially supported by the European Social Fund and Republic of Bulgaria, Operational Programme “Development of Human Resources” 2007-2013, Grant № BG051PO001-3.3.06-0048.

## REFERENCES

- Bulgarian Small and Medium Enterprise Promotion Agency – [www.sme.government.bg](http://www.sme.government.bg)
- Shahpazov G., L. Doukovska - Structuring of Growth Funds with the Purpose of SME’s Evolution under the JEREMIE Initiative, Proc. of the Second International Symposium on Business Modeling and Software Design - BMSD’12, 4-6 July 2012, Geneva, Switzerland, ISBN 978-989-8565-26-6, pp. 159-164, 2012.
- European Commission, “SEC (2011) 876 final/2”, Brussels, 27.10.2011.
- The Global Competitiveness Report 2011, [www.ced.bg](http://www.ced.bg).
- Atanassov K. - Generalized Nets. World Scientific, Singapore, New Jersey, London, 1991.
- Atanassov K. - On Generalized Nets Theory, “Prof. M. Drinov” Academic Publishing House, Sofia, Bulgaria, 2007.