

Low Power Remote Neonatal Temperature Monitoring Device

Hiteshwar Rao¹, Dhruv Saxena¹, Saurabh Kumar³, Sagar G. V.¹, Bharadwaj Amrutur^{1,2}, Prem Mony⁴, Prashanth Thankachan⁴, Kiruba Shankar⁴, Suman Rao⁵ and Swarnarekha Bhat⁵

¹Robert Bosch Center for Cyber Physical Systems, Indian Institute of Science, Bangalore, India

²Department of Electronics and Communication Engineering, Indian Institute of Science, Bangalore, India

³Department of Instrumentation and Applied Physics, Indian Institute of Science, Bangalore, India

⁴Division of Epidemiology and Population Health, St. John's Research Institute, Bangalore, India

⁵Department of Neonatology, St. John's Medical College Hospital, Bangalore, India

Keywords: Neonatal Monitoring, Wearable Sensors, Telemedicine, Body Sensor Network, Temperature Measurement, Temperature sensors, Skin Temperature, Noninvasive Wearable Wireless Monitoring System, Biomedical Measurements.

Abstract: In this paper we present the design of a wearable temperature sensing device for remote neonatal monitoring. It is designed for continuous and real-time monitoring of the infants in remote rural areas, for the first few weeks after their birth. It is capable of sensing the neonate's skin temperature with 0.1° C accuracy to detect the early onset of hypothermia. The sensed data is transferred securely over bluetooth low energy radio to a nearby gateway, which then relays the information to a central database for real time monitoring. The device incorporates a medical grade thermistor which is directly interfaced to a microcontroller with an integrated bluetooth low energy radio. Low power optimizations at both the circuit and software levels ensure sleep currents of only 1uA, ensuring very long battery life. The device is packaged in a baby friendly, water proof housing and is easily sterilizable and reusable.

1 INTRODUCTION

Neonatal Mortality Rate (NMR)(WHO et al., 2012) is defined as number of newborn deaths (that is within the first 28 days of life) per thousand births. The global neonatal deaths today account for more than 40% of all child deaths before the age of five and is estimated to be more than 8 million(Oestergaard and Inoue, 2011). More than 95% of these deaths occur in developing nations like regions of Africa and South Asia. Reports(Global Health, 2010) have shown that India has about 10 times higher NMR compared to the western world. NMR in India was 31 as of 2011, a 33% decrease in NMR since 1990, yet taking into account its burgeoning population, approximately 1 million newborn died in 2010, nearly 30% of the global neonatal deaths(WHO, 2012).

Recent research indicates that hypothermia is increasingly considered as a major cause of neonatal morbidity and mortality, especially in rural resource constrained settings(Kumar et al., 2009)(Kumar et al., 2008). Hypothermia for neonates is defined as an aberrant thermal state of diminution of their body's

temperature below 36.5°C. Further decrease in body temperature causes respiratory depression, acidosis, decreases the cardiac output, decreases the platelet function, increases the risk of infection and may even lead to fatality without preemption(Macfarlane, 2006). WHO has classified hypothermia into following three categories depending on the body temperature(WHO, 1993).

- Mild hypothermia: 36.0 to 36.4°C
- Moderate hypothermia: 32.0 to 35.9°C
- Severe hypothermia: < 32°C

In newborns, hypothermia can be caused by loss of body heat to surroundings through conduction, convection, radiation or evaporation. Premature newborns are even more susceptible to these factors because of their low weight at the time of birth, they have a large 'surface area to weight ratio' with minimal subcutaneous fat. They have poorly developed shivering, sweating and vasoconstriction mechanisms and they are unable to retain their body's heat(Macfarlane, 2006). Hypothermia has a wider spread in the developing nations. In the rural context

thermal care of newborn is often overlooked and hypothermia goes undetected. The most prevalent technique in rural settings on which caregivers rely is human touch, which is less sensitive and is not a reliable method. Commonly used mercury thermometers are often fragile and require some degree of training. Hence there is a need for an automated and robust way of measuring the neonate's temperature on a continuous basis, and be able to initiate intervention in a prompt manner as required. This has been the main motivation towards developing the temperature monitoring device and system.

The ever increasing cost for state-of-the-art medical facilities like NICU (Neonatal Intensive Care Unit) impedes the user from accessing it in rural areas. The problem is exacerbated in rural parts as India's population is still largely rural, with limited or no access to modern health care infrastructure. Mothers are often discharged earlier and infants are taken home right after delivery. In some cases delivery is even carried out at their residence without any medical professional or facilities at their disposal. We would like to capitalise the technical advancements of 21st century to perform remote neonatal healthcare monitoring in an economical manner.

In this paper, we propose a novel wearable monitoring device, designed and developed for the neonates in remote, rural and resource constraint settings. Our objective is to develop an ultra low power wireless skin temperature sensor, capable of monitoring newborns' body temperature unobtrusively and in real time over a span of the first few days to weeks. Sensed temperature data will be securely uploaded via a gateway device to a centralised database. Analytics on the temperature data will be run to determine the intervention needed in case of temperature excursions beyond normal levels. This system will be given to new mothers to take home after delivery.

However this will require solutions to a number of significant challenges like ultra low power sensing, device integration and packaging, ultra low power short haul communication and baby friendly design.

1.1 Requirements and Challenges

We conducted a user study in the NICU of St. John's Medical College Hospital in Bangalore, India. The study involved understanding the current techniques and equipment used in NICU to monitor the health of the neonates. This led to understandings in how the neonates are handled and how their vital parameters such as body temperature are measured. It also revealed concerns of the doctors regarding current equipment and the feasibility of use of such equip-

ment in a remote rural setting. Issues like placement of the sensor on the body, ability of the device to be sterilised and other aspects which will be highlighted in the coming sections, were dealt with through brainstorming sessions and concept generation. Feedback from the doctors/neonatologists was taken time and again on the concepts generated which led to a more concrete list of requirements.

1.1.1 Safety

In an NICU setting neonates are kept under radiant warmers to regulate their body temperature. To achieve this, neonates' body temperature is constantly monitored by employing conventional temperature probes, attached to their skin with adhesive tape as shown in figure 1.



Figure 1: Neonate kept under radiant warmer in NICU at St. John's Medical College Hospital.

The skin of neonates is extremely delicate and vulnerable to environmental stress. Research (Susan et al., 2001) has shown that increase in microbial growth under temperature probe can be harmful. Medical tape causes irritation and when it is removed it causes skin abrasion and damage (Rutter, 2000). Risk of the damage of internal organs involved with the tympanic and rectal temperature measurement limits their use for continuous monitoring. Thus the primary concern and requirement is their protection, safety and non-invasive monitoring.

For continuous measurement of body temperature the safest potential location for the sensor is over the right upper quadrant of the abdomen just below the rib-cage.

1.1.2 High Accuracy

For monitoring hypothermia or hyperthermia, temperature measurement accuracy should be same as that of medical grade NICU temperature probes. Thus an high accuracy of 0.1°C should be achieved in a remote rural setting.

1.1.3 Longer Battery Life

Once the device is installed and given to the user, neonates should be continuously monitored for the

duration of first 2 to 3 weeks, with a sampling period of once every 15 minutes. Battery should last long enough without any need for charging or replacement. This calls for an ultra low power design to meet the requirement of longer battery life.

1.1.4 Robustness

The device needs to unobtrusively operate for several days. During the operation in remote regions, manual intervention for maintenance or repair is difficult to provide. Hence the device should be robust enough to cater to challenges like shock, vibration, and should not get reset accidentally. It should be hermetically sealed to protect the electronics from getting damaged in case liquids seep in during sterilisation or due to contact with body fluids (e.g sweat, urine, faeces, etc.). Moreover, the device should be adjustable so that it can be used on neonates of different abdominal girths, it should be aesthetically pleasant and should be baby friendly.

Detailed description of the solution to these requirements and challenges is provided in section 2.3

1.2 Related Works

In India, remote rural health monitoring is being enabled by many companies and government agencies. For instance, in (Neurosynaptics, 2002), the company has developed a health kiosk and system called ReMeDi, which is deployed at the primary health center. The Kiosk allows a number of basic health tests to be conducted, the results of which are communicated over the cellular network to a central repository which keeps track of patient health data. This system is in use in a number of rural districts in Bihar and parts of Karnataka. Many other similar systems are being developed and deployed by various NGOs and startups across India.

Studies indicate that monitoring certain basic parameters, like temperature, could help indicate impending problems and hence with timely intervention, perhaps the mortality can be reduced. In this regard, an innovative product, for keeping babies warm, has been developed by a startup called Embrace (Embrace, 2012).

In a related work, authors in (Chen et al., 2010) describe some sensors and packaging which has been developed for monitoring newborns. The sensors are embedded in a smart jacket, with careful attention paid to the baby friendliness of the design.

Another device (iThermometer, 2012) addresses a similar application where temperature of body can be measured and transmitted wirelessly to an android platform based device. The device has a battery life of

only 48 hours and a relatively larger size as compared to our design.

The authors in (Isetta et al., 2013), report an internet based health monitoring system for newborns. The parents fill up an online form with some data about their babies regularly. These include: Weight, body temperature, sleeping patterns, skin color, feeding etc. The remote nursing staff monitor these parameters and provide timely advice. The authors conducted a clinical research study for the efficacy of this system and found that it helped reduce the number of visits to the hospital by a factor of 3 for the babies being monitored via this system, as compared to a control group, which did not use it. This study encourages us to develop automated monitoring techniques like in (Chen et al., 2010) which will be more reliable and efficient than manually entering the data.

2 SYSTEM DESIGN

This section describes the design decisions involved in developing the hardware platform and the prototype device

2.1 Wireless Communication

There are many low-power wireless technologies like Bluetooth low-energy (BLE), Bluetooth classic, ANT, ZigBee, Wi-Fi, Nike+, IrDA, and the near-field communications (NFC) standards currently being employed in the field of healthcare.

For our application, the following critical key parameters drove the selection of the wireless interface: ultra-low-power, low cost, small physical size, application's network topology requirements and security of communication.

The authors in (Artem et al., 2013) do a power consumption analysis of BLE, ZigBee and ANT sensor nodes in a cyclic sleep scenario and find BLE to be the most energy efficient. We believe that in the next few years, millions of mobiles and computers will support BLE, thus enabling BLE based sensors to utilize these as gateways to the internet ((Alf Helge, 2010) and (Gomez et al., 2012)). We already see commercial products with BLE like FitBit (Hawley E et al., 2012), Pebble Watch and Hot Watch, and hence it encourages us to leverage the advantages of employing BLE as the short-range wireless communication technology for connecting the sensor to the gateway.

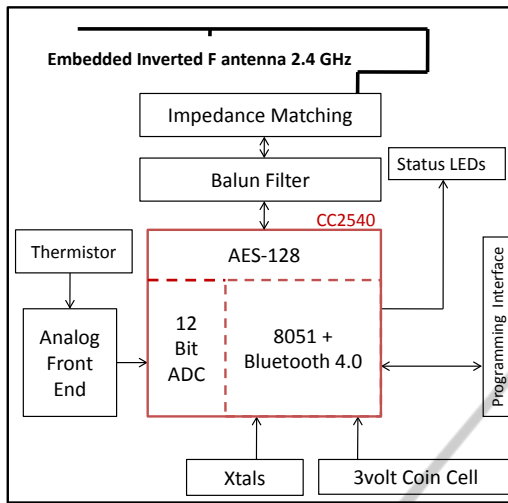
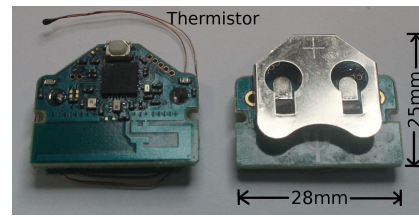
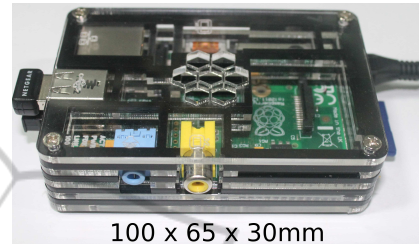

Figure 2: Block diagram of the temperature sensor.



(a) Top and bottom view of the sensor



(b) "Raspberry pi" as a gateway device

Figure 3: Hardware platforms.

2.2 Hardware Platform

2.2.1 Sensor Platform

A monolithic design of sensor platform is required to minimize the form factor, facilitate ease of manufacturing and to reduce the overall cost of the product. Hence a custom made platform has been developed using a multilayer Printed Circuit Board. The assembled sensor platform has a dimension of 28 mm x 25 mm x 8 mm.

The sensor hardware platform as shown in Figure 2a and consists of a Microcontroller(MCU) with integrated Bluetooth 4.0(BLE) and a 12-bit ADC (CC2540 from Texas Instruments), the NICU grade temperature sensor with its analog front end circuit, status LEDs, power supply and RF balun filter and antenna for wireless communication over 2.4 GHz ISM band. The microcontroller system has 256 KB programmable flash memory and 8-KB RAM and supports very low-power sleep modes, with sleep current as low as only $0.4\mu A$. There is built-in 128-bit hardware AES support for secure communication.

Sensor hardware can be programmed wirelessly and application programs can be downloaded on MCU's flash over the air via mobile or a gateway device. This feature enables us to dynamically control the sensor platform without having to disassemble the module and remove it from the package.

High precision MF51E NTC thermistors (Canterm, 2009) are used for extremely accurate temperature measurements. These are especially designed and calibrated for medical equipment. The extremely small size of thermistor allows it to respond very quickly to small variations in temperature.

The temperature profile running on sensor meets the universal standard of body temperature profile defined by Bluetooth SIG (Bluetooth, 2012). Hence our sensor device can communicate to any authenticated host independent of the gateway platform being used.

2.2.2 Antenna Selection and Performance

The antenna for the sensor device has to balance between small size and efficiency. High efficiency antenna enables larger separation between the sensor device and the gateway - thus simplifying the usage scenario. On the other hand, larger size impacts the overall device size which is not desirable for a wearable device. A chip antenna offers a very small footprint solution but leads to a compromise of some critical parameters, such as:

- Reduced efficiency (or gain)
- Shorter range
- Smaller useful bandwidth
- More critical and difficult tuning
- Increased sensitivity to components and PCB
- Increased sensitivity to external factors

Detuning of chip antenna happens due to its proximity with ground plane, power source, plastic enclosure and the condition whether it is worn by the user or not. Our experiments with the chip antenna indicated an effective range of only about 3 meters. To overcome these issues, we have used an embedded Inverted F-antenna (IFA). Performance and characteristics of both the antennas are tabulated below.

The Inverted-F Antenna has higher efficiency, longer range and a wider bandwidth than a chip antenna, though larger in size. For our device, the coin

Table 1: Comparison of chip antenna and Inverted-F Antenna.

Parameters	Chip antenna	IFA
Range [†] (m)	3-5	10-12
Bandwidth* (MHz)	100	300
Efficiency*	90%	50%
Reflection loss*	< 10%	> 50%
Cost	Low	Nil
Size (mm)	8 x 6	25.7 x 7.5

[†]: Measured in closed indoor environment

*: Obtained from dataheet(TI, 2008)

cell was another size limiting factor and hence we found this to be a good choice which provides high performance at a very low cost.

2.2.3 Low Power Analog Front End

Conventional thermistor interfacing techniques (Boano et al., 2011) use a linearization circuitry followed by a gain stage(G) and finally a ADC(A) as shown in figure 4(b). We could eliminate most of these components in our approach shown in figure 4(a), by using the high precision thermistor, a high precision low tolerance low temperature coefficient resistor R_1 and the high resolution 12 bit ADC in the CC2540. Thanks to the well defined Temperature - Resistance characteristics of the thermistor the non-linearity can be taken care of by solving following log-polynomial Steinhart-Hart equation in software.

$$\frac{1}{T} = A + B \ln(R_{Th}) + C (\ln(R_{Th}))^3 \quad (1)$$

A, B, and C are the Steinhart-Hart coefficients which are provided by the manufacturer (Cantherm, 2009). This non linearity correction can be done either in the gateway or the sensor, thus incurring no power penalty on the sensor device itself.

The minimum voltage resolution for the 12 bit ADC operating at full range of 0–3V is 0.732mV. For the use case in which the sensor module will be employed, the temperature range lies from 25°C–40°C. The minimum accuracy requirement within this temperature range is 0.1°C which corresponds to a minimum change of 2.743mV for the sensor module, well above the LSB of the ADC and hence eliminates the need for a separate gain stage.

As per the circuit shown in figure 4(a) analog voltage reference for 12 bit ADC ($M = 12$) is also supplied from digital I/O. Therefore the voltage at the input of ADC is given by

$$V_{ADC} = \frac{N_{ADC}}{2^M} V_{REF} = \frac{R_{Th}}{R_{Th} + R_1} V_{REF} \quad (2)$$

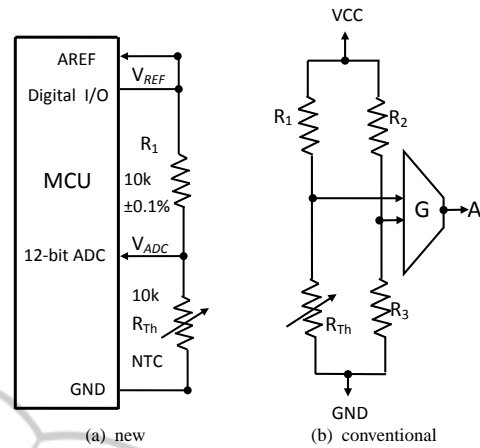

Figure 4: Thermistor interfacing technique.

From above equation R_{Th} can be calculated independent of the voltage supplied by digital I/O.

$$R_{Th} = \frac{N_{ADC}}{2^M - N_{ADC}} R_1 \quad (3)$$

For the change in R_{Th} due to ± 1 LSB variation of ADC and tolerance of R_1 ,

$$\Delta R_{Th} = \frac{R_{Th} (2^M) \Delta N_{ADC}}{(2^M - N_{ADC}) N_{ADC}} + \frac{(N_{ADC}) \Delta R_1}{(2^M - N_{ADC})} \quad (4)$$

The proposed approach uses a single resistor R_1 with a low temperature coefficient of $\pm 10 ppm/^\circ C$ and a tolerance of 0.1%. For $R_1 = 10K\Omega$, ΔR_1 is $\pm 10\Omega$ due to tolerance and $\pm 2\Omega$ due to temperature change of 20°C. Therefore, total $\Delta R_1 \approx \pm 11\Omega$. ΔR_{Th} due the change in ± 1 LSB of ADC is calculated to be $\pm 10\Omega$ at 25°C and $\pm 5\Omega$ at 42°C.

From equation 4 the total ΔR_{Th} due to ± 1 LSB variation of ADC and tolerance of R_1 is found to be $\pm 15\Omega$ at 25°C and $\pm 12\Omega$ at 42°C. This corresponds to an error margin of $\pm 0.03^\circ C$ at 25°C and $\pm 0.08^\circ C$ at 42°C. Error margin is within our accuracy requirement. The thermal noise from the resistors are negligible.

The conventional approach suffers from increased errors due to the number of resistors used because each has its own temperature dependence and tolerance values. Another drawback of the earlier technique is that current is constantly consumed by the wheat-stone bridge and the gain stage, irrespective of the microcontroller being in sleep mode. In the proposed design, since the sensor interface is powered from the microcontroller's GPIO, the current consumption can be significantly reduced by suitably programming the GPIO output during the sleep mode.

This is illustrated in the measurements of both the conventional and the proposed approach in table 2.

The use of well calibrated thermistor and a very



Figure 6: Prototyped temperature sensor with belts.

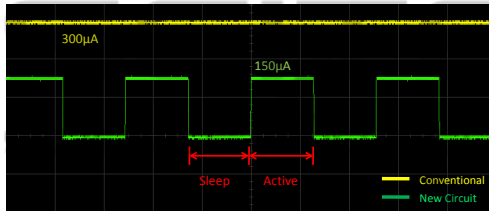

Figure 5: Current consumption during active and sleep mode.

Table 2: Current consumption comparison.

Mode	New circuit	Conventional
Active mode	150µA	300µA
Sleep mode	0µA	300µA

low tolerance resistor eliminates the need for any other calibrations saving the cost and effort.

2.2.4 Gateway Platform

The sensor communicates with the gateway and the temperature data is stored on a centralized database over a secured internet backbone provided by GPRS/Wi-fi. We have developed the gateway using both a smartphone (Google Nexus 4) as well as a low cost platform “Raspberry pi” as shown in figure 3(b). Raspberry pi has a 700MHz ARM core as an application processor and 512 MB RAM. Dual USB connectors are used for BLE and Wi-Fi dongles. A Linux based operating system is booted on it to run the application program. In the case of the smartphone an android application connects to the sensor and relays the information to the server.

2.3 Prototype and Implementation

The prototype developed includes a casing which

houses the electronics and a belt which is used to fasten the casing around the abdomen of the neonate. Compared to monolithic design approach of (Chen et al., 2010) by integrating sensors into textile, our modular approach of designing a separate belt and enclosure facilitates the sterilization, assembly, cost reduction and easier interchangeability of the device.

2.3.1 Temperature Sensing Interface

The thermistor has a dimension of 1.6mm x 4mm and is required to be in thermal contact with the test surface to measure its temperature. However due to the requirements of the device to be robust and safe for the neonate (without any sharp/pointy objects sticking out of the device) the sensor was placed in contact with a thermal interface which would touch the body of the neonate on one side and house the sensor on the other side as depicted in Figure 7.

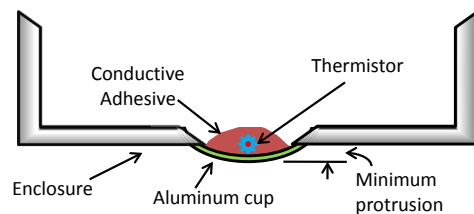

Figure 7: Vertical cross-section of the enclosure.

The interface consists of an aluminium cup made by cold-working of an aluminium sheet. Aluminium was chosen for its easy formability as well as ability to retain its shape once it is cold-worked. Aluminium also has a very high thermal conductivity ranging from 200–250 W/m.K, which enables our thermal interface design to attain thermal equilibrium with the body of the patient in a short span of time. The aluminium cold-worked cup is only 0.1mm thick

to minimize the heat loss. To ensure complete thermal contact, the thermistor is glued on the inner side of the aluminium cup with a highly thermally conductive copper tape which ensures efficient and quick conduction of heat from the aluminium surface to the sensing element. The cup is securely housed inside the casing while ensuring that it protrudes slightly from the bottom surface of the casing to enable reliable thermal contact with the body of the patient.

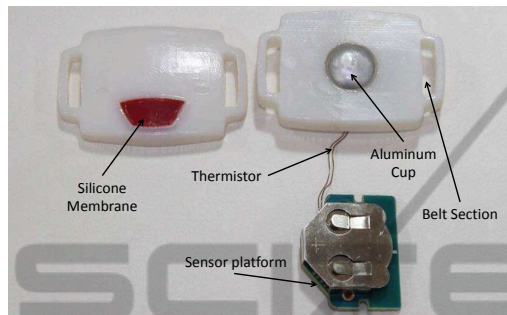

Figure 8: Disassembled prototype.

2.3.2 Power Switch

The device is designed to stay in deep sleep by default when not operational. To initiate connection establishment with a BLE gateway, we have provided a power switch, which needs to be pressed and held for 5 seconds or more. However since the same switch is also used to reset the device it is placed at a short depth inside the casing to minimise the chance of accidental reset. A silicone membrane is flushed with the top surface of the enclosure such that only if the membrane is pressed to a depth of 3 mm or more will the switch get activated. This requires concentrated force on the center of the membrane. Experiments were conducted to check if any sort of accidental pressing could lead to such a situation and it was concluded that only intentional pressing could achieve such a result. The silicone membrane also ensures that the casing is water tight.

2.3.3 Enclosure

The enclosure is required to be water tight to protect the electronics from liquids used for sterilization as well as from urine. Moreover the casing needs to be made with minimum number of parts for ease of production and low cost. The methods for making the casing water tight are either to make a simple lip interface in the design where the top and bottom parts can be pasted, or to go for a more complicated design which involves either snap fits or screw fittings and requires rubber gaskets to make the device water tight. The former method although cheaper

to manufacture has the disadvantage that the casing can only be used one time. However since the device does not need battery replacement for several months, the former method seems more feasible given the fact that even an openable casing will be prone to damage since it will move from patient to patient and might eventually be required to be replaced. The custom designed enclosure as shown in the figure 6 is rapid-prototyped with the latest and higher resolution 3-D printing technology (Stratasys, 2013). The 3-D printed prototype was drop tested from a height of 2 meters without any damage to the prototype and enclosed circuitry. The actual production model however would be even more robust due to higher strength of commonly used injection molding materials like Polypropylene or Acrylonitrile butadiene styrene (ABS).

2.3.4 Belt Design

Respiration rate for newborns varies from 30–60 breaths per minute and during a respiration cycle the abdomen region expands and contracts. An increase in the height of the sternum of around 1/2 cm is considered as a normal expansion (Scavacini et al., 2007). Hence the belt has to be designed with the requirements of being

- soft and elastic to accommodate the changes in abdominal circumference during breathing
- able to accommodate different sizes of neonates
- washable for sterilization and reuse

All the above requirements were met through a design where the belt is made out of a soft fabric. The belt has a thin elastic band inside the fabric which can be elongate upto 3 cms, hence it dynamically allows for expansion of the belt during breathing. The belt also has small loops in which fastening velcro can be attached. The fastening velcro is placed at the ends of the belt and when the belt folds on itself, the velcro hooks come in contact with the loops thereby fastening the belt. This allows for accommodation of different sizes of neonates. The fabric is completely washable and the belt can be washed and dried for reuse. Multiple belts can be assigned for a patient and these belts can be replaced daily to maintain hygiene.

2.3.5 Baby Friendly Design

The industrial design of the device reflects the face of a friendly abstract toy, where form follows function. All features of the face have functional relevance. To keep the number of parts to a minimum, light gates have been avoided by making the sections under which the LEDs are housed thinner than the



Figure 9: Baby friendly enclosure.

overall casing. The thin sections allow light from the LEDs to be seen well. These sections also give the appearance of eyes for the face. The membrane for the switch forms the mouth and the cavities through which the belt passes give an appearance of ears. This friendly face appearance of the design could help enforce confidence in parents that the device is friendly and is safe for their child. This design was arrived at after multiple iterations and discussions with the Neonatologists at SJRI. Initial prototypes were improved through feedback from the Neonatology team and features like exposed edges, sharp corners and crevices as well as exposed buttons were removed and the final design was presented which has been accepted by the Neonatology team.

3 EVALUATION

This section describes the evaluation method employed for testing our sensor platform. Experimental results indicate that the device has the required accuracy. Later in the section power calculation is performed to estimate the battery life.

3.1 Experimental Setup

As described in the section 2.3.1 temperature sensing element is thermally interfaced with aluminium. To determine the response time and accuracy of the packaged module, experimental setup shown in the figure 10 is used.

A glass beaker filled with 300 ml of water is placed on a hot plate. An accurate RTD based temperature sensor is placed in the beaker. The temperature of water is controlled by giving a closed loop feedback to hot plate's heating element. The sensor device is immersed in water bath along with a bare thermistor. A precision digital thermometer is employed for setting reference temperature. Packaged devices were kept immersed in the water bath for 10 hours of continuous operation and the temperature measurements

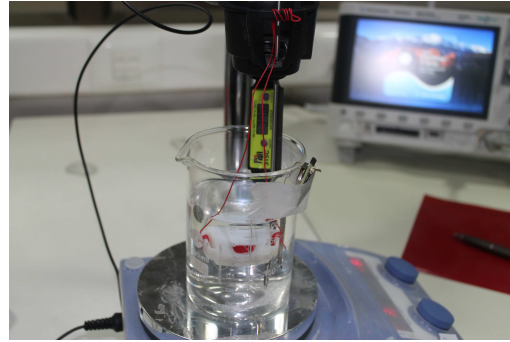

Figure 10: Experimental setup.

were logged wirelessly. Temperature readings from all the sensors were periodically sampled once every two minutes.

3.2 Results

3.2.1 Responsiveness

Figures 11(a) and 11(b) show the temperature measurements during the experiment. A periodic oscillation of the temperature waveform was observed, indicating the action of the servo control loop of the hot plate. The period of the oscillations is approximately 40 minutes and is within $\pm 0.3^\circ\text{C}$ of the temperature configuration being used.

By definition, responsiveness is the time taken by the system to respond to an event or a change, hence these small changes in temperature provides an ideal environment to determine the response time.

Table 3: Response time and sensitivity comparison.

Parameter	Bare	Reference	Packaged
Response	$< 4\text{sec}$	$\approx 3\text{min}$	$\approx 4\text{min}$

The bare thermistor is fastest in responsiveness followed by the reference thermometer and finally the packaged device. The observed response times are shown in table 3, indicating that the packaged sensor would take approximately 3–4 minutes to attain thermal equilibrium with the surroundings. In our actual application scenario, we are required to take continuous temperature readings once every 15 minutes, hence the responsiveness is well within our requirement limits.

3.2.2 Accuracy

Using the same configuration for measuring the accuracy, water was heated upto 40°C and then was allowed to cool down to room temperature. Figure 11

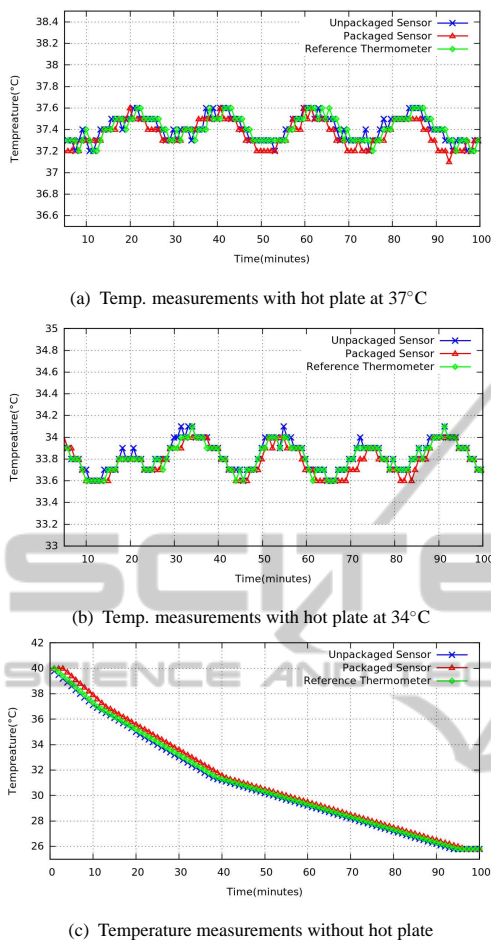

Figure 11: Responsiveness and accuracy measurement of the sensor.

(c) shows the logged temperature reading. The variance (error bar) in the reading from the sensor device is $\pm 0.04^{\circ}\text{C}$. By comparing the data obtained from the sensor with a high precision digital thermometer it was calculated that the error was within 0.1°C for the temperature range of 25°C to 40°C .

3.3 Power Consumption

The sensor device establishes a connection with the near by gateway device through initial advertisement. After a successful connection event, the sensor is configured for periodic sleep and data transmission. Figure 12 and Table 4 shows the measured current and energy consumed by the device during these modes of operation. The profile in Figure 12(b) shows typical power consumption over a sensing cycle. Sleep current is measured using 6.5 digit 34411A Agilent multimeter and transient current is measured using hall effect current probe with TDS5104 Tektronix oscilloscope. The initial advertisement is the most energy

expensive - however this action is expected to happen very rarely. The data transmission energy is also significant compared to sleep energy and hence needs to be minimised to ensure long battery life.

3.3.1 Battery Life Estimation

The sensor device is configured to send temperature measurements once every 15 minutes. Thus there will be 96 data transmission cycles in a day. The device is powered by a 3V CR2032 coin cell of 225mAh given capacity. Considering the derated capacity to be 200mAh, the total energy it can deliver is estimated to be 2160 Joules. Total energy consumed by the device during one full day of operation is estimated to be 5.54 Joules which results in a battery lifetime of 388 days (about a year).

4 CONCLUSIONS

Continuous, automated monitoring of vital parameters of neonates in remote rural areas has the potential of saving many lives each year. The current methods are not reliable and the technological intervention enabled by the proposed device can play a major role in getting these vital parameters to the doctors in real time. Critical requirements like reliability and robustness of the device are met through a methodical design approach using state-of-the-art technology like the integrated blue tooth low energy microcontroller, along with optimised sensor electronics and software, to ensure good performance and battery life. Human interface aspects have been incorporated into the device to allow for a friendly yet robust device which fulfils all the physical requirements for the device to be used comfortably on neonates in rural settings while addressing maintenance and sterilisation issues. The design also aims to connect emotionally with the stakeholders like parents of the neonates and health care providers to enforce confidence and a feeling of security. The current design is modular and can be extended beyond temperature measurement.

4.1 Future Research Needed

- From bench-to-bedside and then from bedside-to-community to test the safety, accuracy, acceptability, efficacy, effectiveness, techno feasibility of this device in humans
- Testing through the various phases of clinical trials and other appropriate epidemiological study designs

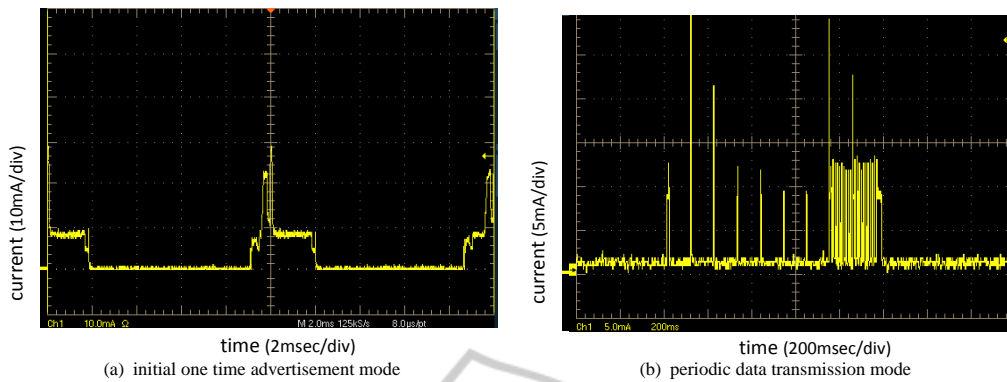

Figure 12: Oscilloscope plot showing current measured using precision current probe for different modes of operation.

Table 4: Current consumption for different mode of operation.

Mode	Peak current	Average current	On Time	Energy from 3V @ 90% η
Sleep	1 μ A	1 μ A	899 sec	1.1 mJ
Data Transmission	30 mA	17 mA	1 sec	56.6 mJ
Initial Advertisement	30 mA	4.5 mA	180 sec	2700 mJ

- Testing within nationally and globally acceptable ethical and legal frameworks for research on human participants
- Testing for potential scale-up on a large-scale

ACKNOWLEDGEMENTS

We acknowledge the Robert Bosch Center for Cyber Physical Systems at the Indian Institute of Science for funding support.

REFERENCES

Alf Helge, O. (2010). Bluetooth Low Energy: Wireless Connectivity for Medical Monitoring. *Journal of Diabetes Science and Technology*, 4(2).

Artem, D., Steve, H., Stuart, T., and Joshua, S. (2013). Power consumption analysis of Bluetooth Low Energy, Zigbee, and ANT sensor nodes in cyclic sleep scenario. *IEEE International Wireless Symposium, Beijing, China*.

Bluetooth (2012). Health tempertute profile. <https://developer.bluetooth.org/TechnologyOverview/Pages/HTP.aspx>.

Boano, C., Lasagni, M., Romer, K., and Lange, T. (2011). Accurate temperature measurements for medical research using body sensor networks. In *Object/Component/Service-Oriented Real-Time Distributed Computing Workshops (ISORCW), 2011 14th IEEE International Symposium on*, pages 189–198.

Cantherm (2009). High precision ntc thermistors. <http://www.cantherm.com/products/thermistors/mf51e.html>.

Chen, W., Dols, S., Oetomo, S. B., and Feijs, L. (2010). Monitoring body temperature of newborn infants at neonatal intensive care units using wearable sensors. In *Proceedings of the Fifth International Conference on Body Area Networks, BodyNets '10*, pages 188–194, New York, NY, USA. ACM.

Embrace (2012). A low cost infant warmer. <http://embraceglobal.org/>.

Global Health (2010). Causes of neonatal and child mortality in india: a nationally representative mortality survey. *The Lancet*, 376(9755):1853 – 1860.

Gomez, C., Oller, J., and Paradells, J. (2012). Overview and evaluation of bluetooth low energy: An emerging low-power wireless technology. *Sensors*, 12(9):11734–11753.

Hawley E, M.-D., Salvatore P, I., and Jonathan A, B. (2012). Movement toward a novel activity monitoring device. *Sleep Breath*, 16(3):913–917.

Isetta, V., Agustina, L., Lopez Bernal, E., Amat, M., Vila, M., Valls, C., Navajas, D., and Farre, R. (2013). Cost-Effectiveness of a New Internet-Based Monitoring Tool for Neonatal Post-Discharge Home Care. *Journal of Medical Internet Research*, (15(2):e38).

iThermometer (2012). Bluetooth digital thermometer for android devices. <http://download.chinavasion.com/download/CVXX-A140.pdf>.

Kumar, V., Mohanty, S., and Kumar, A. (2008). Effect of community-based behaviour change management on neonatal mortality in shivgarh, uttar pradesh, india: a cluster-randomised controlled trial. *The Lancet*, 372(9644):1151 – 1162.

Kumar, V., Shearer, J. C., Kumar, A., and Darmstadt, G. L. (2009). Neonatal hypothermia in low resource settings: a review. *Journal of Perinatology*, 29:401–412.

Macfarlane, F. (2006). Paediatric anatomy, physiology and the basics of paediatric anaesthesia.

Neurosynaptics (2002). <http://www.neurosynaptic.com/>.

- Oestergaard, M. Z. and Inoue, M. e. a. (2011). Neonatal mortality levels for 193 countries in 2009 with trends since 1990: A systematic analysis of progress, projections, and priorities. *PLoS Med*, 8(8):e1001080.
- Rutter, N. (2000). Clinical consequences of an immature barrier. *Seminars in Neonatology*, 5(4):281 – 287.
- Scavacini, A. S. A.-I., Miyoshi, M. H., Kopelman, B. I., and Peres, C. A. d. A. A. (2007). Chest Expansion for Assessing Tidal Volume in Premature Newborn Infants on Ventilators. *Jornal de Pediatria*, 83:329 – 334.
- Stratasys (2013). High-quality, precise, multi-material prototypes in a compact system. <http://www.stratasys.com/3d-printers/design-series/precision/objet260-connex>.
- Susan, B., Debra, D., and Lori A, L. (2001). Neonatal Thermal Care, Part II: Microbial Growth Under Temperature Probe Covers. *Journal Neonatal Network: The Journal of Neonatal Nursing*, 20:19–23.
- TI (2008). 2.4ghz inverted f- antenna. <http://www.ti.com/lit/an/swru120b/swru120b.pdf>.
- WHO (1993). Thermal Control of the Newborn: a Practical Guide. Maternal and Safe Motherhood Programme.
- WHO (2012). Newborn deaths decrease but account for higher share of global child deaths.
- WHO, UNICEF, and UN (2012). Levels and Trends in Child Mortality Report.