

A Framework for Process-based Collaborative Systems Design

Khoutir Bouchbout, Nassim Iklef and Sara Khaldoun
Computer Science Department, EMP Bordj-El-Bahri, Algiers, Algeria

Keywords: Collaborative Business Process, Model-Driven Approach, B2B, Web Services, E-ordering System.

Abstract: In today's business world, collaborative systems can be realized by implementing Business-to-Business (B2B) collaborations that entail a process-oriented integration among heterogeneous and autonomous organizations. In this paper, we define a model-driven framework to design such collaborative systems. The framework comprises three layers: an organizational layer, that focuses on business collaboration requirements, a conceptual layer, to define the business process, and a technology layer, aimed at business process execution. Hence, the framework combines business process management (BPM) concepts and Web services technology. To build B2B collaborations both organizations have to provide public parts of their process models as basis for discussion for collaborative process modelling. The internal private processes are generated from collaborative process, based on model-driven approach (MDA). At the execution level, B2B interactions are modeled based on Web services. Finally, we validate our proposition with the implementation of an e-ordering system.

1 INTRODUCTION

The recent rapid development in the Internet based communications, business process and information system integration possibilities have contributed to the emergence of cross-organizational collaborations. It covers a broad spectrum of applications that enable an organization to form electronic relationships with its suppliers, customers, and other partners (Bauer *et al.*, 2006). Modern business process management expands to cover the partner organizations' business processes across organizational boundaries, and thereby supports organizations to coordinate the flow of information among organizations and link their business processes, forming a Collaborative Business Processes (CBP). Henceforth, there is a need for supporting and modelling CBP enabling the joint execution of business collaboration. In order to enable CBPs, information exchanges must increase among all business applications involved to achieve visibility of collaborative systems.

B2B interactions are declined under different ways and using different technologies, listed from old to recent as follows: (1) exchanging data via traditional means such as fax, phone, and mail; (2) using Electronic Data Interchange or email for data interchange; (3) utilizing private or public exchanges

to share business process information; and (4) deploying Web services and business process management (BPM) tools to coordinate loosely coupled services into integrated cross-organizational processes with real-time data sharing (Chen *et al.*, 2007). Consequently, designing such collaborative systems has raised growing interest among information systems researchers (Lippe, 2005). This is a hard work task and must be based on standards and open technologies to support loose coupling, autonomy, flexibility, and ensuring trust and security (Bauer *et al.* 2005, Chebbi *et al.* 2007).

In this work, we mainly focus on the use of business process modelling and Web services standards in support of B2B collaborations. So, we propose a design framework in a top-down manner, beginning with the collaborative (inter-enterprise) level as main business process template and after the private (intra-enterprise) level as their sub-processes.

The structure of this document is as follows. In section 2, we discuss the basic concepts of collaborative business process. Section 3 analyses the current literature on B2B collaboration design frameworks. Subsequently, section 4 is the main contribution of this paper, as it presents the details of our framework. Next, section 5 assesses the capabilities of proposed solution. Finally, section 6 draws some conclusions and outlines some further research activities.

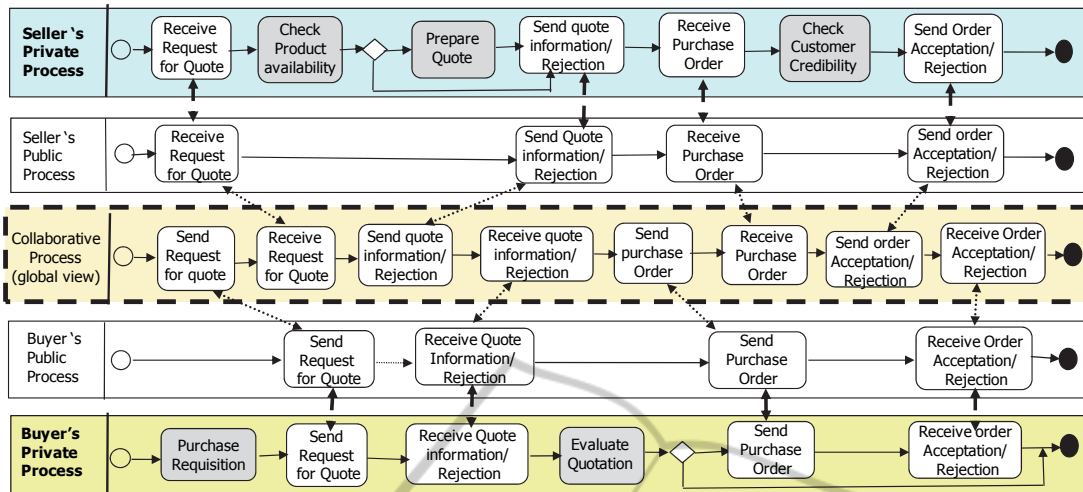

Figure 1: Basic scenario of ordering collaborative business process.

2 COLLABORATIVE BUSINESS PROCESS

Recently, CBP are turning to be an important issue of contemporary BPM. To explain specifics of CBP modelling, we will discuss their requirements.

2.1 Characteristics of Collaborative Business Process

CBP comprise activities executed by different organizations that are working together to reach a common business objective. So, CBP usually do not have a centralized control instance or process owner (Chebbi *et al.*, 2006). Besides, it depicts the different roles involved in the collaboration and their specific responsibilities with regard to the collaboration scenario. Hence, it requires an agreement on how to interact and exchange information, business documents and messages between business partners.

In addition, the privacy and autonomy requirements are at the top priority of participant's organizations. Having this concern in mind, each involved organization has to implement not only its private processes but also its external behavior, allowing better separation of the information density of different areas of concern. So, three different concepts are defined: *Private* (internal), *Public* (abstract or view) and *Collaborative* (cross- or inter-organizational) processes. In order to illustrate these different process categories, Figure 1 presents Business Process Modeling Notation (BPMN) activities of an ordering process where buyer and seller businesses collaborate together.

2.2 Collaborative Business Process Modelling Languages

Although modeling CBP is a complex task, many research efforts have been based on approaches for distributed Workflow management, e.g. (Aalst *et al.*, 2001, Chebbi *et al.* 2006, Lippe *et al.* 2005), current extensions of process language (Touzi *et al.*, 2008), and B2B standards like ebXML- electronic business using eXtensible Markup Language (Dorn, 2007), but has been limited to a single view point at time (e.g. process layer) and they do not fulfill the collaborative interactions issues with multiple view points (both business and technological levels). This is so because they should represent multiple actors participating in each collaborative task while keeping consistency of the overall processes. Hence, most of the process languages such as UML AD – UML Activity Diagrams, EPC – Event-driven Process Chain, BPMN (OMG, 2011), BPEL – Business Process Execution Language (Peltz, 2003) and Web Service Choreography Description Language (Dorn *et al.*, 2007) provide insufficient support for modelling CBP and do not offer a collaborative and integrated modelling framework comprising all levels of abstraction.

Having these considerations in mind, our approach provides an UML profile (Dorn *et al.*, 2007) ensuring more expressive power for CBP modeling. It provides a high level of abstraction on which the partners first agree on the business goals of their collaboration. It should cover comprehensive aspects of CBP specifics such as interaction flow, partner's role, message exchanges, public and private activities.

3 RELATED WORK

The recent years brought a vast number of publications around the collaborative systems topic. We will briefly refer to some of them which are achieved in the field of inter-organizational Workflows or B2B collaborations (Aalst *et al.* 2001, Lippe 2005, Greiner *et al.* 2006, Ziemann *et al.* 2007, Huemer *et al.* 2008, Legner *et al.* 2008, Touzi *et al.* 2009). However, in contrast to this paper, they miss some research clearly addressing holistically the collaborative systems design at business, process and technological levels. They are also rather vague.

Legner *et al.* (2008) have presented a method for modelling inter-organizational processes and deriving business services in three steps. A framework of conceptual inter-organizational business modelling is then defined containing a public process model which serves as reference for the participating organizations (Step 1). Then, the existing private processes have to be assigned and eventually aligned to the agreed public process model (Step 2). After that, the public process interface is realized by business services leveraging web service technology (Step 3). The business process model is used to derive XML-based business documents that are exchanged between business services. In addition, private process modules are transformed into workflows for business process automation which can be implemented using BPEL.

Another relevant contribution in this area is the proposal made by Huemer *et al.* (2008). They have developed a methodology dealing with collaborative processes called United Nations/CEFACT Modelling Methodology (UMM). UMM specifies collaborative business processes involving information exchange in a technology neutral, implementation-independent manner. UMM is a UML modelling approach for global choreographies of B2B scenarios. It is a top-down approach that makes use of worksheets to capture domain requirements. UMM do not provide a complete development process to generate CBP executions. It only provides a development process for modelling technology-independent CBP.

The work of Touzi *et al.* (2009), has proposed a model-driven approach to design a collaborative information system (CIS) dedicated to deal with exchanged data, shared services and collaborative processes. The CIS design crosses the different abstraction layers (business, logic and technological) and exploits at each level the associated models to build the models of the next level. The model of a CBP is BPMN-oriented and based on the SOA

(Service Oriented Architecture). Its meta-model has been defined by referencing the BPMN specifications as well as the CBP aspects.

The framework proposed by Ziemann *et al.* (2007) presents a method for the creation of collaborative process on a conceptual level. They described how cross-organizational business processes can be modelled and transformed to technical process models in the form of Web Service protocols. Their framework can be instantiated using EPCs (design phase) and BPEL (implementation phase) to describe models in different life cycle phases and demonstrated the transitions between these phases. However, a description of how organizational roles can be communicated to partners is missed.

Greiner *et al.*'s work (2006) describes the designing and the implementing of cross-organizational business processes including different levels of technical detail: the business level, the technical level and the execution level. They identify how the mappings and the transformations are needed among private process, view process and CBP among the different levels. The business level models illustrate the organizational business aspects. The technical model secures the technical realization of the process integration and represents the bridge to the process execution.

Though significant research efforts, collaborative systems design is neither taken up broadly nor can it be considered a solved problem. Yet, while the proposed solutions strive to enable the operation of a CBP, no explicit consideration of generic business process requirements, as viewed by the different involved stakeholders (business analysts, process designers and IT specialists), is made to relate to generic collaborative scenarios by combining business process and Web services. To the best of our knowledge, generic business process modeling and execution as Web services in the realm of collaborative systems design as given in this paper have not been published before.

4 THE PROPOSED MDA-BASED FRAMEWORK

In order to establish B2B collaborations one may start "bottom-up" from the private processes or "top-down" from the CBP. In top-down design approach, we note that the business requirements drive the technology. It starts with a global view on the collaboration efforts. This requires that the agreed CBP was defined jointly, before, by the partners.

In this work, we follow the top-down approach because it is more appropriate for an e-Ordering system. Hence, our approach helps to develop partner’s public processes that are compliant to each other. This is guaranteed by the fact that each partner derives its public process consistently to a commonly agreed CBP. It enables a process-based collaborative systems development at both business and technological levels, based on a MDA (Model-Driven Architecture) approach (Bauer *et al.* 2005, Frankel 2003). To define a valid separation between business, software and technological platforms in the information systems, MDA uses different kind of models: (1) *Computation Independent Model (CIM)*; (2) *Platform Independent Model (PIM)*; (3) *Platform Specific Model (PSM)*.

In addition, MDA approach is characterized by a set of vertical transformations across different phases (PIM to PSM and PSM to Code) using model transformation languages like ATL - Atlas Transformations Language (Bézivin *et al.* 2003, Santos *et al.* 2013). A transformation definition is a set of rules that, all together, describe how a model, expressed in a source language, can be mapped into a model in a target language.

Therefore, in Figure 2 we depict the proposed framework which supports: the design of CBP independent of particular process model standard; and the automatic generation of each partner’s side specifications based on a process model standard (in our case BPMN and BPEL) from CBP models (using UML AD profile). It is mainly based on the technique of meta-model transformations

(Hammoudi *et al.*, 2010).The proposed framework is organized into three levels from the abstract conceptual level (collaborative interactions) to the technical execution level (Web services executed via partner’s web sites).

The main benefits of our holistic framework are: increase of the abstraction level, since the focus is on the design of technology-independent CBP; reduction of development costs and time and guarantee of alignment of a business solution with a technological solution, since process executions are generated automatically from process models. We present below in detail the different design phases composing our framework.

4.1 Collaborative Business Agreement Definition Phase

The collaborative business requirements phase at CIM level consists in analyzing the problem domain and identifying the collaborative business requirements. This is jointly carried out by the involved enterprises. CBP usually do not have a centralized control instance or process owner. Hence, it depicts the different roles involved in the collaboration and their specific responsibilities with regard to the collaboration scenario.

So, it needs close coordination among networking partners which requires an agreement (common objective that partners agree on) on how to interact and exchange information, business documents and messages.

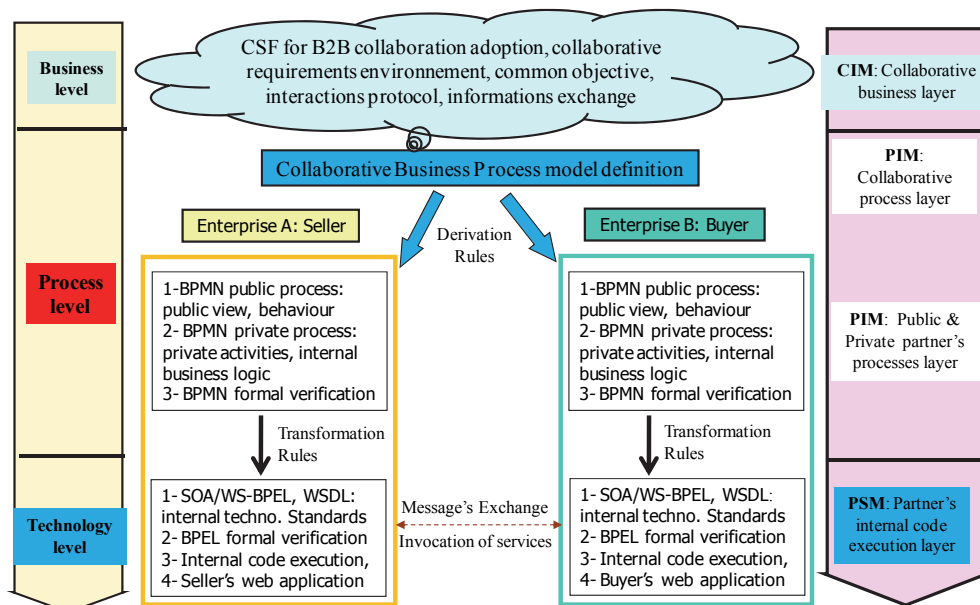

Figure 2: MDA-based method for B2B systems development.

4.2 Collaborative Process Modelling Phase

In this work, modelling CBP follows an MDA-based approach (Santos *et al.*, 2013), proposing a set of models at different levels of abstraction and model transformations to connect them, as depicted in Figure 3. At the PIM level, we model CBP using an UML AD profile based on extended process meta-model. The use of this meta-model and UML profile add semantics and constraints to the UML AD meta-model (with stereotypes, constraints and tagged values) and provide a vocabulary more suitable to model CBP. In addition, this language encourages a top-down approach to model CBP and provides the conceptual elements to support the modelling of CBP main aspects:

- Definition of the participants (partners and their collaboration roles) of a CBP with their communication relationships with description of the common objective that partners agree on.
- Definition of collaborative business processes (interorganizational) as informal specifications of a set of activities performed by partners.
- Representation of business documents to be exchanged in CBP with providing the concepts to define their syntactic and semantics structure.
- Description of the public interfaces of each collaboration role performed by partners. A public business process contains business operations that support the asynchronous message exchange of interactions between partners.

However, it is essential to enable partners to make sure the correctness of the execution of CBP. This formal verification task is concerned to check the process model is free of logical errors such as deadlocks, livelocks, etc. (Aalst *et al.*, 2010). Hence, in order to verify the correct execution of the process models, we developed a formal verification software tool using Petri Nets. So, we can easily verify UML AD, BPMN and BPEL business process models.

4.3 Generation of Partner’s Public Processes Phase

As we are shown before, CBPs are not executable. Hence, CBP requires the definition of public and private processes each organization has to implement for executing collaborative process. A public process defines the public behavior of the role an organization performs in a CBP at PIM layer. It defines the externally visible behavior of a business partner in terms of the activities that support the receiving and sending of messages and business documents with each other.

By deriving public process from the CBP, we ensure that the semantics of each CBP element is represented in terms of the elements and semantics provided by BPMN from one partner’s viewpoint (e.g. seller or buyer) as depicted before in Figure 2. This is represented by the fact that UML AD model *applies* UML AD profile as depicted in Figure 3 (by means of discontinued red arrow).

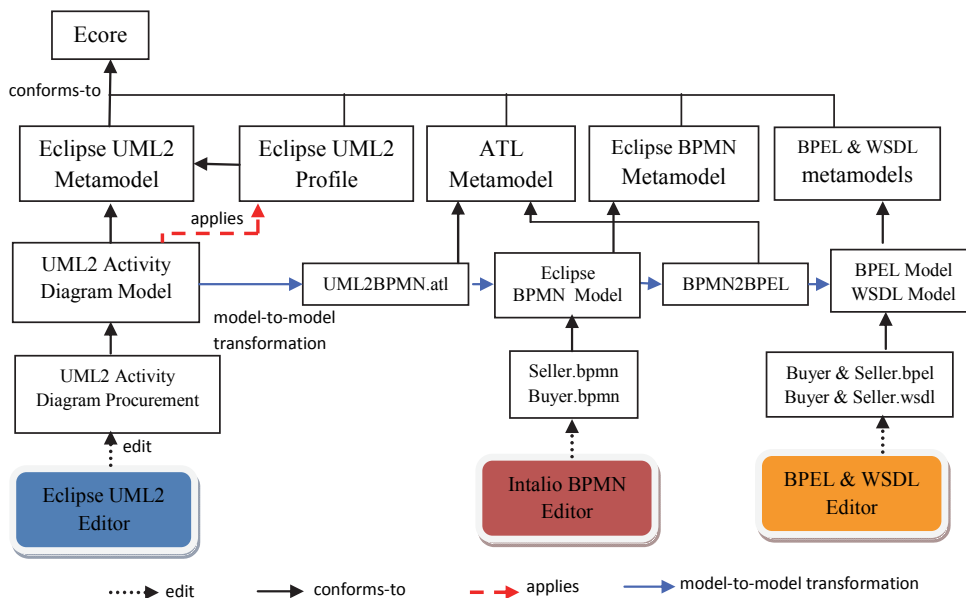

Figure 3: Process model transformations engine.

For this purpose, we define automated process model transformation engine (see Figure 3). Henceforth, UML Activity Diagram and BPMN models have some elements share the same semantic meaning. These elements are transformed directly without considering about the element context or neighbourhood elements (one-to-one transformation rule). In addition, some UML Activity Diagram element types cannot be transferred directly to BPMN elements. To be able to remain the same semantic meaning, two or more elements in BPMN will be translated to one UML Activity Diagram element (many-to-one transformation rule).

4.4 Definition of Partner's Private Processes Phase

The private executable process is derived from a public process at each partner's side (see Figure 3). It adds the private logic of the enterprise required to achieve the role within a global CBP. The internal business logic includes the activities for producing and processing the exchanged information/documents as well as data transformations and invocations to internal systems. Internal or private activities (see the seller's private activities of Figure 1), which are required for generating the information to be sent and processing the information to be received from partners, have to be added to the public process to define the private process.

In our case, in order to realize the BPMN-to-BPEL process model transformation, we implement an algorithm inspired from Ouyang *et al.* (2009), namely BPMN2BPEL. It takes as input a BPD (BPMN Business Process Diagram) represented in XML format and produces the correspondent BPEL code as an XML file.

However, it is difficult to develop complete translation rules, so the result of the translation needs validation from process modeler. Consequently, we can use the transformation rules as a semi-automation translation method to reduce the time for him when translating the process models manually.

Beside the process model transformation engine, we consider the business processes as the key focal point of Web services design. Henceforth, each of the activities in the process model must be implemented with one or more services. Below we describe this task in two steps:

Step1: Determine objectives and describe the business process structure: The first step in the service design is to determine the business process objectives and describe the business structure and

the functions of the business process. The business process structure refers to the logical flow or progression of the business process. The functions of a business process are expressed in terms of the activities or the services that need to be performed by a specific business process.

Step2: Describe business activity responsibilities (roles): The second step in the service design is to identify responsibilities associated with business process activities and the service providers that are responsible for performing them. Each activity within a business process is associated with a particular Web service provider who fulfils a defined role (responsibility) within the process. Each service provider is expected to properly fulfill the business responsibility of implementing the Web service, or set of Web services, which perform that activity within the process under the role that the provider is expected to undertake.

4.5 Code Execution and User Interfaces Phase

CBP provides a global or public view on participants collaborating in a peer-to-peer fashion by offering distributed Web services in order to achieve a common business goal. This step deals with the user interface applications development for the "seller" and the "buyer" roles in an ordering system. Furthermore, on the execution layer these internal processes are used e. g. for the orchestration of Web services (Peltz, 2003). It consists on the generation of the XML-based specifications of business processes and the collaborative systems' interfaces of an organization from its platform-specific IT model, which contains the necessary information for the code generation.

To this aim, we have implemented a direct connection with the business applications of the buyer organization communicating directly with a seller's web application to send and receive information. After collaborating, both of the two partners' applications progress independently.

5 IMPLEMENTATION OF A COLLABORATIVE SYSTEM

In order to validate our approach, a tool support is essential. For this purpose, we have implemented an e-Ordering system. The main objective of the order fulfillment process that buyer expected is supplier can deliver qualified products to fulfill its orders at

the right time and right place. So, buyer and supplier have to collaborate by sharing and exchanging business information.

To this aim, we use an Eclipse-based integrated platform (Eclipse, 2011) to guarantee the interoperability of the different plug-ins, tools and ATL transformation languages. Thus, we develop an Eclipse-based ATL code for the building of process model transformations (e.g. from collaborative to specific BPMN). In this way, the derivation of the private process (e.g. seller) from the CBP ordering process is carried out with this ATL tool.

In this work, we implement the basic collaborative process scenario, where a buyer (University) makes an online order to a seller (Suppliers), who processes and fulfils the order, as shown in Figure 4. Hence, we implemented an e-Ordering application for each partner's side, representing activities of executable business processes as Web services. So, interactions between seller and buyer are achieved as invocation of partner's services.

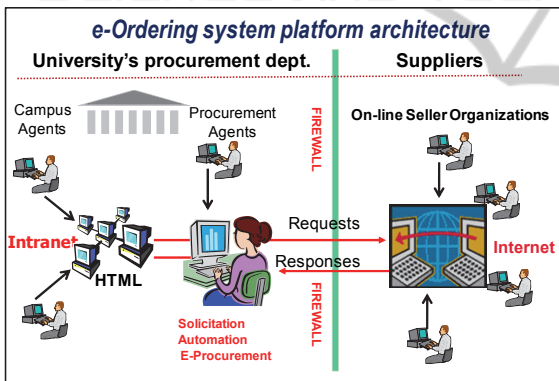

Figure 4: Architecture of e-ordering system.

```

The input ATL query (sample):
1 query bpel2code =
2 bpel!Process.allInstances()->
3 select(e | e.oc1IsTypeOf(BPEL!Process))->
4 collect(x | x.toString().writeTo('C:/BPEL/' + x.name '.bpel');

The generated executable BPEL code (sample) from the Eclipse file 'bpel2code.atl':
1 helper context BPEL!Process def : toString() : String =
2 '<process \t name="' + self.name + '"' +
3 '\n\t\t\t targetNamespace="http://ode/bpel/' + self.name + '"' +
4 '\n\t\t\t xmlns="http://docs.oasisopen.org/wsbpel5/2.0/process/executable"'
5     self.partnerLinks.toString()+
6     self.variables.toString()+
7     self.sequence.toString()+
8 '</process>';
    
```

Figure 5: Process model transformation to executable BPEL code.

Figure 5 shows the process model transformation to executable BPEL code generation implementing web services as mentioned before in section 4.5.

In addition, we have developed in parallel a software tool implementing formal verification techniques which have to be applied to corresponding Petri Nets representation of business process. This tool is applied at the three framework levels (verification of UML AD, BPMN and BPEL business process models). Four verification properties (Deadlock, bounded, liveness and quasi-liveness) are implemented as shown in the right side of Figure 6 of the process of the example depicted before in Figure 1.

6 CONCLUSION

In the frame of this work, we have proposed a MDA-based framework for designing collaborative systems. It combines the concepts of BPM and Web services technologies. We defined collaborative business process model. Thereafter, the specific partner's processes are derived from the collaborative process. Moreover, the collaborative B2B interactions between partners are represented, using Web services technology, at executable level.

Finally, there are several open issues to address in the future. Thus, we plan to evaluate our framework through a scenario with three business partners (enterprise, supplier and shipper) in order to verify the completeness and generality of the proposed concepts and artifacts. Another aspect that requires further research is to investigate the explicit support of heterogeneity of data formats and messages using the ontology concepts.

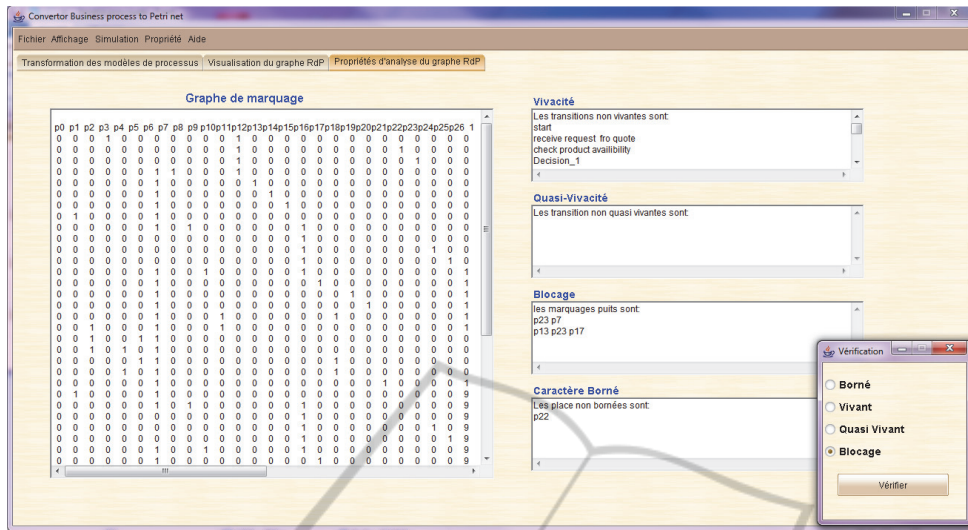

Figure 6: Verification of ordering process properties using Petri Net based software tool.

REFERENCES

- Aalst Van der W.M.P. and Weske M. 2001. The P2P approach to Interorganizational Workflows. *In Proc. of CAiSE'01, LNCS Vol. 2068*, pp.140-156. Springer.
- Aalst van der W. M. P., Van Hee K., ter Hofstede A., Sidorova N., Verbeek H., 2010. Soundness of Workflow Nets: classification, decidability, and analysis. *Formal Aspects of Computing*, pp. 1-31.
- Adam, Hofer, Zhang, 2004. Cross-Enterprise Business Process Management Architecture – Methods and Tools for Flexible Collaboration, In Proc. of MIOS.
- Bauer B., Müller P., and Roser S., 2006. A Decentralized Broker Architecture for Collaborative Business Process Modelling and Enactment, In Proc. of the 2nd Int. Conference IESA'2006, pp. 115-126.
- Bauer B. Muller J.P., Roser S., 2005. A model-driven approach to designing cross-enterprise business processes, Volume 3292 of LNCS, Springer.
- Bézivin, J., Dupé, G., Jouault F., 2003. First Experiments with the ATL Model Transf. Language: Transforming XSLT into XQuery, In proc. of 2nd OOPSLA.
- Chebbi I., Dustdar S., Tata S., 2006. The view-based approach to dynamic inter-organizational workflow cooperation, *DKE*, Vol. 56, pp.139-173.
- Chen M., Zhang D., Zhou L., 2007. Empowering collaborative commerce with Web services enabled business process management systems, *Decision Support Systems*, Vol.43, pp. 530-546.
- Dorn J., Grün C., Werthner H., and Zapletal M. 2007. A Survey of B2B Methodologies and Technologies: From Business Models towards Deployment Artifacts. Proceedings of HICSS'07, USA.
- Eclipse Organisation: Eclipse Platform, URL: <http://www.eclipse.org>, accessed on June 2012.
- Frankel D.S., 2003. Model Driven Architecture – Applying MDA to Enterprise Computing. Wiley.
- Greiner, U., Lippe, S., Kahl, T., Ziemann, J. 2006. Designing and implementing cross-organizational business processes. In Proc. of I-ESA'2006.
- Hammoudi S., Alouini W., Lopes D., Huchard M. 2010. Towards A Semi-Automatic Transformation Process in MDA: Architecture, Methodology and First Experiments. *IJISMD*, Vol.1 Issue 4, pp. 48-76.
- Huemer C., Liegl P., Schuster R., Werthner H., and Zapletal M., 2008. Inter-organizational Systems: From Business Values over Business Processes to Deployment. Proc. of DEST'2008.
- Legner C., Vogel Tobias, Löhe Jan, 2008. Transforming Inter-Organizational Business Processes into Service-Oriented Architectures. Method and Application, In Proc. of KiVS'2007, Switzerland.
- Lippe, Greiner, Barros, 2005. A Survey on State of the Art to Facilitate Modelling of Cross-Organisational Business Processes. In Proc. of XML4BPM 2005.
- Santos N., Duarte F.J., 2013. A Transformation of Business Process Models into Software-Executable Models Using MDA, LNBIP Vol.133, pp 147-167.
- OMG: BPMN 2.0, 2011. available at: <http://www.omg.org/BPMN/>, accessed on June 2012.
- Ouyang, C., Dumas, M., Aalst, W. M. P., Ter Hofstede, A.H.M., 2009. “From business process models to process-oriented software systems”, *ACM Trans. on Software Eng. Methodology*, Vol. 19(1), pp.1-37.
- Peltz Chris, 2003. Web services Orchestration and Choreography, *IEEE Computer*, 36(10), pp.45-52,
- Touzi J., Bénaben F., 2009. A Model-driven approach for collaborative service-oriented architecture, *Int. J. of Production Economics*, Vol. 121 No 1, pp. 5-20.
- Ziemann Jorg, Matheis Thomas, Freiheit Jorn, 2007. Modelling of Cross-Organizational Business Processes, Proceedings EMISA'2007, LNI, Vol.119, pp.87-100.