

Intelligent Robotic Approach for After-stroke Hand Rehabilitation

Nirvana Popescu¹, Decebal Popescu¹ and Mircea Ivănescu²

¹Department of Computer Science, University Politehnica of Bucharest, Bucharest, Romania

²Department of Mechatronics, University of Craiova, Craiova, Romania

Keywords: Post-Stroke Rehabilitation, Robotic Glove, Intelligent Control, Speech Recognition.

Abstract: This paper presents the design of an intelligent haptic robotic glove (IHRG) model for the rehabilitation of the patients that have been diagnosed with a cerebrovascular accident (CVA). Total loss or loss of range of motion, decreased reaction times and disordered movement organization create deficits in motor control, which affect the patient's independent living. The control system for a rehabilitation hand exoskeleton is discussed. One contribution is given by using a velocity observer and a force observer for performance evaluation. The disturbance effects are eliminated by a cascade closed loop control with velocity and force observers. The performance of the control system is demonstrated by the simulation. The second proposed control implementation version has a great advantage - the possibility to specify some vocal commands, which will help the patient to make a lot of medical exercises by themselves.

1 INTRODUCTION

The scientific community has become increasingly interested in so-called Rehabilitation Robotics, a branch of the areas of Robotics and Mechatronics that addresses to the study of complex robotic systems aiming to restore the human functions for those people who suffer major trauma as a result of strokes and cerebrovascular accident (CVA). A CVA occurs when a blood vessel (an artery) that supplies blood to an area of the brain bursts or is clogged by a blood clot. Within minutes, the nerve cells in that area are affected and they can die in a few hours. As a result, the part of the body that is controlled by the affected area of the brain cannot function properly (Greibenstein, 2010).

Total loss or loss of range of motion, decreased reaction times and disordered movement organization create deficits in motor control, which affect the patient's independent living. Recent studies have shown that intensive and repetitive training may be necessary to modify neural organization and recover functional motor skills. Several researchers (Reynaerts, 1995; Rodriguez-Cheu and Casals, 2006; Zhao *et al.*, 2006; Lucas *et al.* 2004) have reported significant improvement in patients' daily activities due to higher training intensities, even in the CVA chronic phase. However, there were several opinions in the literature claiming that the repetitive training is

not very efficient (French *et al.*, 2010) and other papers proved that there are some reduced improvements (Barbay *et al.*, 2013). On the other hand there are authors that certified the improvement arm movement ability (Housman *et al.*, 2009).

The current health care system provides stroke rehabilitation in the intensive care hospital setting, in the rehabilitation setting and in the outpatient setting. In the last decade, the literature presented numerous concepts and techniques that allow evaluation of the hand physiological properties, structure, characteristics and especially the functional anatomy. There is a great need to develop new approaches for rehabilitation of the upper limb after stroke. Robotic therapy is a promising form of neurorehabilitation that can be delivered in more intensive regimens than conventional therapy (Kitago *et al.* 2015). Numerous studies (Carrozze *et al.* 2003; Birglen and Gosselin, 2003, 2004; Biagiotti *et al.*, 2009, Lotti and Vassura, 2005, Brokaw *et al.* 2011, Jiting *et al.*, 2011) have allowed the development of kinematic structures to reproduce as much as possible the human hand kinematics.

This paper presents the design of a low-cost Intelligent Haptic Robot-Glove (IHRG) for the rehabilitation of the patients that have been diagnosed with a cerebrovascular accident (CVA). The IHRG is an exoskeleton that supports the human hand and hand activities by using a control architecture for dexterous grasping and manipulation. IHRG is a

medical device that acts in parallel to a hand in order to compensate some lost function.

In order to design an exoskeleton structure and to develop techniques that allow rehabilitation of the main anatomical features of the hand, in the context of extremely varied range of patients with various problems of malfunction, the architecture presented in this paper should cover the range of issues and anatomical structures.

Feedback is important in rehabilitation. Rehabilitation is most effective when users get immersive feedback that relates to the activities they imagine or perform. For example, if people imagine grasping an object with their left hand, then an image of a grasping hand can help users visualize their activity. If a stroke patient keeps trying to imagine or perform the same movement, while receiving feedback that helps to guide this movement, then users might regain the ability to grasp, or at least recover partial grasp function. In the last few years, totally novel and promising application for motor imagery (MI) - based Brain-Computer Interface (BCI) has gained attention (Irimia *et al*, 2012, 2014).

In the case when patients can talk and the stroke did not affect their vocal capacity of pronouncing words, a new design of IHRG is also presented in this paper. The implementation is made based on some hardware platforms. One of them is Arduino Mega 2560 which is a hardware platform that determines the movement of some small engines that will help the patient to open or close one or more fingers. The second one is the Raspberry Pi hardware platform which was used in order to make all the calculations specific to voice recognition. Using a microphone, the patient can send vocal commands to IHRG or can select one predefined program which will imply some exercises for a specific period of time.

One major contribution of this paper consists of using observers for this type of rehabilitation system. All the analysed papers, some of them being included in the state of the art of this work, have used velocity sensors for performance evaluation. Instead, we used velocity observers and force observers for doing this. The second contribution regards the voice recognition based implementation that offers the facility of live interaction between the system and the patient.

The paper is structured as follows: section II presents the design and development of the structure of the intelligent haptic robotic glove that includes hand biomechanics, the exoskeleton architecture and the control architecture; section III shows a different control approach based on voice recognition and details the hardware implementation in this case; section VI is concerned with conclusions.

2 DESIGN AND DEVELOPMENT OF IHRG STRUCTURE

For a correct analysis of hand function, a researcher must thoroughly analyse three main components: the upper hand and wrist, fingers (four) and thumb. Different biomechanical movements of flexion, extension, abduction and adduction were analysed, considering the amplitudes, movement directions, axes and planes. The model of hand articulations is presented in Figure 1.

Carpal osteoarticular complex is so constituted as to permit carrying out movements of flexion-extension, abduction – adduction and circumduction. Because these joints are plane, each of them allows sliding movements of small amplitude. Wrist joint movements occur simultaneously: both in radiocarpal and mediocarpal joints. All these movements are accomplished by sequential displacement of region segments: the second carpal (distal) moves on the first carpal (proximal) and then the latter slipped on the forearm. Functional position of the hand is the active position, ready to grab. This means that hand makes a dorsal flexion with 20° , the fingers are slightly flexed and the thumb is in opposition. The muscles are slightly tensed; the extensors of the hand and the flexors of fingers exert a dominant action on antagonists. This is an important aspect since in the case of stroke occurrence and central level control interruption, this normal anatomic position is accentuated being accompanied by spasticity.

Using haptic interface technology allows for reaching and grasping movement executed by hand to be assisted by a robot that direct the movement to a specific target. Until now, the technologies developed for this purpose have the potential to revolutionize the way hospitals operate, reducing the recovery stroke cost while allowing therapists and clinicians to manage a large number of patients in the same period of time.

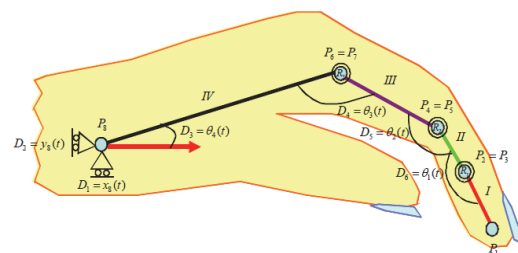

Figure 1: Hand joints model.

2.1 The Exoskeleton Architecture

One of the proposed solution is to develop a mechanical architecture consisting of a cascade of articulated elements, whose design to cover as much as possible the anatomic and functional finger phalanges, providing support for the actuation system.

Two architectures were analysed: the 4-bar mechanism and the tendons mechanism. In tendons mechanism architecture, the three phalanges of the finger are realized as a serial structure of three rotation joints, each joint being controlled in cascade by the previous joint through a tendon-cable that is coupled on the pulleys system associated with each joint. In this case, kineto-static analysis principles were studied. Then it was considered a finger architecture based on 4-bar mechanism where the movement is achieved by successive deformations of the 4-bar mechanisms associated with each phalanx of the finger.

The proposed architecture is a control architecture where the control is performed at the first active joint, the other joints being passive and realizing movements based on the associated bar system (Popescu *et.al.*, 2013). The global architecture of one finger exoskeleton and of the entire structure can be seen in Figure 2.

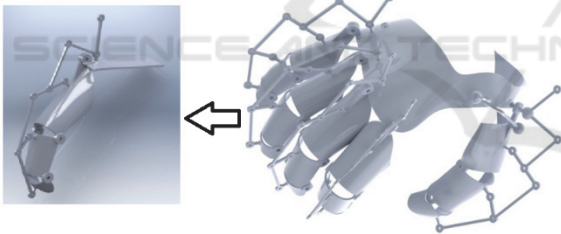

Figure 2: The global architecture of one finger exoskeleton and of the whole hand.

2.2 The Control Architecture

The control architecture was developed considering that the control is performed at the first active joint, the other joints being passive and realizing movements based on the associated bar system. The proposed overall structure is shown in Figure 3.

It can be observed the distribution of forces on the phalanges. A kinetostatic analysis was performed, the movement of three phalanges being realized planar. A coordinate system X_i, Y_i, O_i and an articulated bar system with parameters: a_i, b_i, c_i are assigned to each phalanx of l_i length. The finger movement is achieved by rotating each finger phalanx with the angles θ_i ,

θ_2, θ_3 . The control forces on the external environment, F_1, F_2, F_3 are applied in d_1, d_2, d_3 representing the contact points on a human hand. It is considered the active torque T_a applied on the finger joint 1.

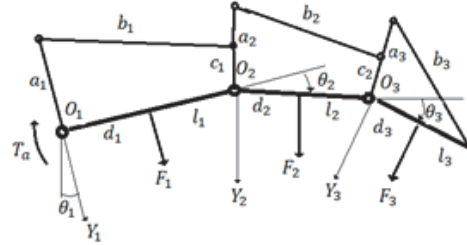

Figure 3: The 4-bar mechanism architecture of a phalanx.

Our approach also proposes a control scheme dedicated to underactuated fingers with the intention of maximizing the capabilities of the control using position information. Position sensors are implemented on the mechanical transmission system and used to enhance the behaviour of the hand despite its limited number of control signals. Several positions of a finger in a rehabilitation exercise are illustrated in Figure 4.

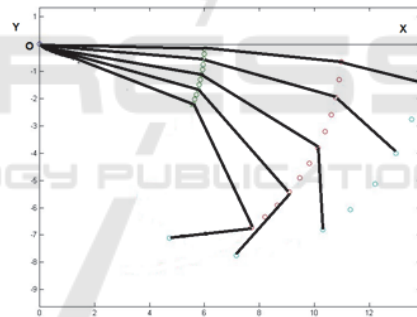

Figure 4: Finger motion for a rehabilitation exercise.

The control system needs self-tuning to adjust dynamics and kinematics of the system. This self-tuning has to compensate effects of internal and external disturbances: model uncertainty, load, friction and compliance with human finger. In some research works, the force control for grasping is obtained by using tactile feedback. The limited space on the finger surface makes very difficult the introduction of a sensor on that area. For this reason, velocity and force observers are used to implement the control technique.

The actuation system for each finger is based on one dc motor moving a slider device which transmits motion to the phalanges by several coupled „four-bar” mechanisms. The dynamic model of the

actuation system and load mechanism is described by the following equations

$$Li(t) + R i(t) + k_e \omega(t) = u(t) \quad (1)$$

$$J\dot{\omega}(t) + k_\omega \omega(t) + k_s \theta(t) = \tau(t) - \tau^{dis} \quad (2)$$

$$\tau(t) = k_i i(t) \quad (3)$$

$$\omega(t) = \dot{\theta}(t) \quad (4)$$

where i, ω, θ, τ are the state parameters: the drive current, mechanical angular velocity, angular position, motor torque, respectively, L, R, k_e represent the electrical motor parameters: armature inductance and resistance and back EMF constant, respectively, and J, k_ω, k_i, k_s are mechanical parameters: nominal inertia, damping constant, nominal torque constant and spring constant. Also τ^{dis} is an equivalent disturbance torque that focuses the effect of friction, external forces determined by the compliance with human finger and unmodeled dynamics in the transmission mechanism.

The design of the force observer is based on (Lucas *et al.*, 2004) and estimates the force from the dynamic model of motion, avoiding the use of the acceleration signal, measured or construct from velocity by differentiation. By using (2), (4) (with $\tau^{dis} = 0$), the force observer is defined by

$$\dot{\hat{\tau}} = -L \hat{\tau} + L (J\dot{\omega} + k_\omega \omega + k_s \theta) \quad (5)$$

where $\hat{\tau}$ is the estimated force-torque and L represents the observer gain (in order to simplify the notation, the variable t is omitted). We select the observer gain as

$$L = \alpha / J, \alpha > 0 \quad (6)$$

A classical cascade disturbance closed loop control is proposed in Figure 5. The system contains the actuation system, mechanical transmission system and a conventional controller (for example, a PID controller). Measuring signal is the angular position θ .

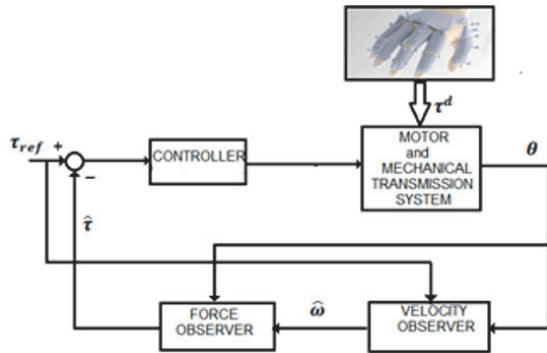

Figure 5: A cascade closed loop control with observers.

A velocity observer is used to generate the estimated value of velocity $\hat{\omega}$ using the reference value of the torque, τ_{ref} . This signal is used in the force observer to generate the estimated value of the torque $\hat{\tau}$. The forces between hand and exoskeleton act as the disturbances τ^{dis} . The classical conventional tuning rules are used for the control parameters in order to compensate the disturbances and to ensure the motion performances. The disturbances are determined by the resistance increasing to passive finger extension. Characterization of hypertonia can be difficult due to the highly variable nature of the hyperactivity of the finger flexors and the characteristics of each patient.

The observer error will be

$$e_\tau = \tau - \hat{\tau} \quad (7)$$

From (6) yields

$$\dot{e}_\tau = \dot{\tau} - \dot{\hat{\tau}} \quad (8)$$

We assume that the torque varies slowly relative to the observer dynamics (Lucas *et al.*, 2004; Chen *et al.*, 2000; Xian *et al.*, 2004)] and it was supposed that

$$\dot{\tau} = 0 \quad (9)$$

In terms of this condition, from (5), (10), the error dynamics becomes,

$$\dot{e}_\tau = -L e_\tau = -(\alpha/J) e_\tau \quad (10)$$

that proves that the observer is globally asymptotically stable. The parameter α determines the time constants for the estimation. In order to simplify the observer construction, a function w_τ is defined as

$$w_\tau = \hat{\tau} - \alpha \hat{\theta} \quad (11)$$

By using (5), (10), (11), we obtain the new observer equation as

$$\dot{w}_\tau = -\left(\frac{\alpha}{J}\right) w_\tau + \left(\frac{\alpha}{J}\right) (k_\omega - \alpha) \dot{\theta} + \left(\frac{\alpha}{J}\right) k_s \theta \quad (12)$$

The equation (12) allows the estimation of the torque using the position and velocity signals,

$$\hat{\tau} = w_\tau + \alpha \hat{\theta} \quad (13)$$

The velocity observer aims to estimate the inaccessible velocity signal $\hat{\theta}$ using only the position θ . For a reference torque-force τ_{ref} , the motion equation (2) becomes

$$J\dot{\omega}(t) + k_\omega \omega(t) + k_s \theta(t) = \tau_{ref} \quad (14)$$

and the observer model is selected as,

$$\hat{\theta} = p + k_0 e_\theta \quad (15)$$

$$\dot{p} = k_1 \operatorname{sgn}(e_\theta) + k_2 e_\theta \quad (16)$$

where e_θ is the position error,

$$e_\theta = \theta - \hat{\theta} \quad (17)$$

$\hat{\theta}$ is the estimated value of the angular position and k_0 , k_1 , and k_2 are constant positive observer design parameters.

In order to demonstrate the performance of the control system, a numerical simulation was realized. So, we considered the dynamic model of the actuation system and load mechanism described by (1)-(4), where the electrical parameters of the dc motor are: $L=0.0138$ H, $R= 26.44\Omega$, $k_i =0.1656$ Nm/A, $k_e = 0.982$ Vs/rad and the mechanical parameters of the system are: $J= 0.000254$ kg m² k_Ω , $k_\Omega =0.002031$ Nms/rad, $k_s =2.45$ Nm/rad. The model dynamics (1)-(4) are simulated in MATLAB SIMULINK. First, the force and velocity observers (12)-(13), (15)-(16), respectively, are implemented (Popescu *et.al.*, 2013).

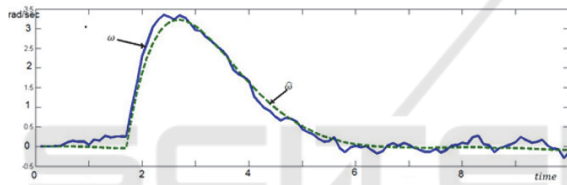

Figure 6: The estimation of velocity by observer.

The velocity signal estimated by the velocity observer is presented in Figure 6. We remark the good quality of estimation. This signal is used as input variable in the force observer. A PID controller was implemented and a cascade closed loop control system (Figure 5) was studied. The results are illustrated in Figure 7.

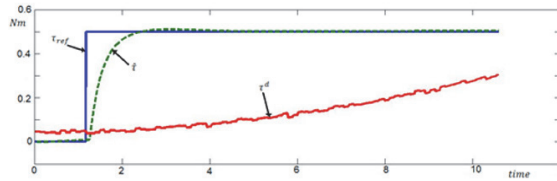

Figure 7: The force control by velocity and force observers.

3 HARDWARE IMPLEMENTATION AND VOICE CONTROL

In this approach, the design of IHRG is made based on some hardware platforms. One of them is Arduino

Mega 2560 which is a hardware platform that determines the movement of small engines that help the patient to open or close one or more fingers. The second one is the Raspberry Pi hardware platform which was used in order to make all the calculations specific to voice recognition. Based on a microphone, the patient can send vocal commands to IHRG or can select one predefined program which will imply some exercises for a specific period of time (Popescu *et.al.*, 2014).

The glove must be very thin in order to have a comfortable environment for exercises. Another aspect, which was taken into consideration, was the fact that this type of glove is like an infrastructure suitable for a lot of wires and sensors. The wires will help the patient to close or open the hand, for example, as long as the sensors will calculate real time the resistance force generated by the patient.

All these calculations are mandatory for knowing the action time of every engine. In fact this time implies the force which is applied for every finger, and this force must be correlated with the reaction obtained from the patient in order to avoid finger fracture. Nylon threads are used for connecting the top fingers with the small engines. There are 5 small engines, one for every finger and they have the major role in implementing operations like open or close. Of course, that these operations will be made partially – the reaction force (the feedback) from the patient is taken in real time and, based on these values, the operation time for every small engine is determined. For this purpose a bending sensor is used – one sensor for every finger.

Another kind of sensor used in the design is the force sensor. This sensor was added for a scenario in which the patient will want to take some fragile objects. These sensors are putted on the top of every finger and will establish when the function of the small engine will be stopped. A two-cell LiPo battery (7.4 V) and 1000 maH battery used in design are enough for 1 day high intensive use of the glove.

For this experiments, Arduino Mega 2560 platform was used in the implementation due to some advantages like:

- 5 ports for PWM signals which are sent to the engines,
- 10 analog ports which are used to read the signals coming from the bending and force sensors,
- 4 serial lines – one of them is used for wireless communication between IHRG and the speech recognition system,
- I2C busses used in order to communicate with the LCD. On this LCD the patient can read the current

program, chosen by himself, and some values for some forces will be displayed here.

For the wireless communication (between the intelligent glove and the control device) 2 xBee modules were used. These modules work at 3.3V and the Arduino board works at 5V. For this reason an xBee adaptor must be included in the design. Another conversion must also be realized – the battery offers 7.4V and the glove operates at 5V – using an integrated circuit LM 7805.

The Raspberry Pi board is used to receive vocal commands, to recognize these commands (speech recognition) and to send these commands wireless to the glove. The microphone and the soundboard are connected to the Raspberry Pi board via USB port. The whole design of the control system is shown in Figure 8.

The software includes some libraries and open source programs like: a voice recognition engine (Julius HTK) which has a large words database, Pexpect used for automatically speech recognition and a Python module developed to control the applications. The first step was to setup the environment such that the Julius engine can start and load at startup all the libraries and dependencies. In the next step the library implementation was made.

This means to establish the vocabulary that will be further used to control the intelligent glove. Then, the vocabulary was translated to a phonetic form and saved in a file with a specific extension (.voca). This file contains every word, which will be used splitted into the corresponding phonemes.

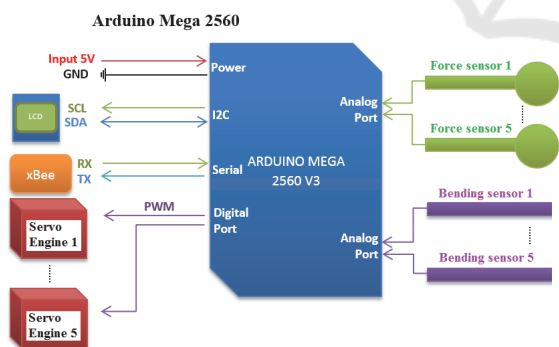

Figure 8: The control system of IHRG using Arduino.

These phonemes represent the sound unit of word. The chosen language was English due to the fact that the recognition level is very high. The English language has usually 44 phonemes, and the determination of them was made verifying 2 sources: the lexicon file, which is available in Julius and the CMU dictionary, which contains phonemes. The next

step involves rules definitions for the grammar, rules that must be respected. After this step the result is a file with *.grammar* extension in which is defined the whole subset of possible sentences. The grammars are described using Backus-Naur form and they will be applied for getting the exact description of the required language. After that, the *mkdfa.pl* script is used to convert the results from the previous steps in a Julian / Julius format. Julian is a special version of Julius doing speech recognition based on acoustic models.

The next step supposes as input the acoustic models correlated with Julius HTK. In this case it is necessary to define the configuration file used by Julius. This is a very important step because in this manner it is possible to define the properties for samples creation. These samples will be processed by HTK. When the Julius application will be started, the patient can also start to use the vocabulary defined in the previous steps. In the identification process, for each word or sentence a score will be obtained. This score will reflect the recognition accuracy level. Also, a Viterbi score is obtained. This Viterbi score is got via identification Viterbi algorithm for the same sequence of hidden state.

HTK interaction involves some steps like the following ones:

Step 1 – install the application and setup the environment in order to have all the dependencies available and also the libraries.

Step 2 – The acoustic models and the training phase are done by the patient. Initially, a number of samples and their exact form will be defined in a file. After that the patient will register his voice using the audacity samples defined in the file.

Step 3 – After all the samples were recorded, it is necessary to define a configuration file that converts the file with *.wav* extension to a file with *.mfc* extension because only this extension is recognized by HTK. This configuration file will be parsed by a script, designed for the corresponding conversion.

For software configuration, in order to obtain acoustic models in audacity, the following settings were made: sample rate of 48Khz, 16 bits per sample, mono channel and the resulting wave file was converted to Microsoft 16-bit PCM format.

The software uses a Python module called Pexpect in order to create a pseudo terminal, which is used to connect to Julius engine. The reason is to obtain the generated output. After that, this output is processed using a filter for initial lines in which a sequence is identified and a score is obtained for it. Then, another filter is applied based on scores and some threshold values. Finally, the value, which

satisfies all the criteria will be recorded and translated to a specific format which, will be further processed by IHRG.

The communication between Raspberry Pi and IHRG is made wireless and uses a protocol. When a command is identified from the patient, a translation code command is generated in order to activate the sensors of IHRG. The codification is:

- for every bending sensor a value between 0 and 9 will be transmitted, where 0 means standby and 9 represents the maximum bending.

- for the force sensor a value between 0 and 4 will be generated, where 0 means a contact and 4 means maximum fundraising amount.

This codification is sent like a string of 6 values. The most significant value is # and the least significant value is ~. For example, the code #55552~ represents the command GRAB.

Table 1: Implemented commands and their codes.

<i>wave</i>	444440
<i>grab</i>	555552
<i>soft grab</i>	333331
<i>strong grab</i>	999994
<i>point</i>	909990
<i>open</i>	000000
<i>close</i>	777770

There are a number of 7 commands implemented and learnt by Julius as it can be seen in Table 1, along with their codes.

The tests that have been done have proved a very good detection for simple commands like: open, close, grab, point or wave. Figure 9 shows the implemented model.

The noise is a factor which can influence the recognition process. If the noise is almost zero, the results of speech recognition are very good; when the level of noise is increasing, the accuracy of speech recognition decreases a lot. Also, in case of Raspberry Pi the tests show that the detections of commands are not so good like in the case in which a personal computer is used.

The precision of results can be improved by modifying the recorded values or changing the Viterbi score. The training phase for the acoustic model is also another way to improve the accuracy. In time, the data grow up and it will be reached a point in which the accuracy remains the same. This point is the maximum point. In order to create an acoustic model used by more patients, it will be mandatory as each patient to contribute with his own audio input in the system.

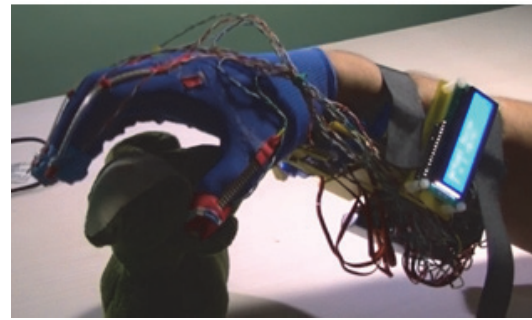

Figure 9: IHRG implementation for the voice recognition control approach.

4 CONCLUSIONS

This paper presented the design of an intelligent haptic robotic glove (IHRG) model for the rehabilitation of the patients that have been diagnosed with a cerebrovascular accident (CVA). Total loss or loss of range of motion, decreased reaction times and disordered movement organization create deficits in motor control, which affect the patient's independent living. Some studies have shown that intensive and repetitive training may be necessary to modify neural organization and recover functional motor skills.

The IHRG is an exoskeleton that supports the human hand and hand activities by using a control architecture for dexterous grasping and manipulation. The five-fingered assistive robotic glove was designed with mechanical compliance of human finger. The biomechanical elements of the exoskeleton assistive hand were designed considering: motion in different planes, adapted to patient's hand, possible to train pinch and grasp, opening/closing game. A global architecture for the hand exoskeleton was presented. The actuation system was also studied and designed. The velocity and force observers are used to implement the control technique.

The post stroke rehabilitation robotic glove was also designed and implemented in our laboratory considering the fact that for any patient it will be more comfortable to make medical exercises in his own home. The second proposed control implementation version has a great advantage - the possibility to specify some vocal commands, which will help the patient to make a lot of medical exercises by themselves. To prove the robustness of this approach, a lot of tests have been done and a very good detection was obtained for simple commands like: open, close, grab, point or wave and also for complex commands like: soft grab or strong grab. Different factors which

can influence the recognition process were also analysed.

One major contribution of this paper consists of using observers for this type of rehabilitation system. All the analysed papers, some of them being included in the state of the art of this work, have used velocity sensors for performance evaluation. Instead, we used velocity observers and force observers for doing this. The second contribution regards the voice recognition based implementation that offers the facility of live interaction between the system and the patient. It is also important to mention the reduced cost of the proposed solution.

The presented approaches represent a part of a work in progress project. We are currently involved in testing the systems to obtain the complete results after working with patients. This represents the subject of a next paper.

Regarding future work, we also analyse the possibility to implement an EEG-based brain-computer interface that can be used to command a semi-autonomous robotic glove by means of motor imagery (MI). The BCI detects the intention to move and provides online feedback to the user. At the same time, the feedback can be used as trigger for different pre-programmed robotic motion tasks.

ACKNOWLEDGEMENTS

This work is supported by PCCA 150/2012 grant of the Executive Agency for Higher Education, Research, Development and Innovation Funding (UEFISCDI).

REFERENCES

- Barbay, S., Guggenmos, D. J., Nishibe, M., Nudo, R. J., 2013. Motor representations in the intact hemisphere of the rat are reduced after repetitive training of the impaired forelimb. *Neurorehabilitation and neural repair*, 27: 381-384.
- Biagiotti, L., Lotti, F., Melchiorri, C., Vassura, G., 2009. How Far Is the Human Hand? A Review on Anthropomorphic Robotic End-effectors, *DEIS - DIEM*, University of Bologna.
- Birglen, L., Gosselin, C., 2003. On the Force Capabilities of Underactuated Fingers, *Proc. IEEE Intl. Conf. Rob. Aut.*, Taipei, Taiwan, pp. 1139-1145.
- Birglen, L., Gosselin, C., 2004. Kinetostatic Analysis of Underactuated Fingers, *IEEE Trans. Rob. Aut.*, 20(2), pp. 211-221.
- Birglen L., Gosselin, C., 2004. Optimal Design of 2-Phalanx Underactuated Fingers, *Proc. Intl. Conf. Intel.Manip. Grasp.*, Genova, Italy, pp. 110-116.
- Brokaw, E.B., Black, I., Holley, R., Lum, P., 2011. Hand Spring Operated Movement Enhancer (HandSome): A Portable Passive Hand Exoskeleton for Stroke Rehabilitation, *IEEE Trans on Neural Systems and Rehabilitation Eng* vol 19, No4, August, pp391-398.
- Carrozze, M.C., Vecchi, F., Sebastiani, F., Cappiello, G., Roccella, S., Zecca, M., Lazzarini, R., Dario, P., 2003. Experimental Analysis of an Innovative Prosthetic Hand with Proprioceptive Sensors, *Proc. IEEEIntl. Conf. Rob. Aut.*, Taipei, Taiwan, pp. 2230-2235.
- Chen, W.H., Ballance, D.J., Gawthrop, P.J., O'Reilly, J., 2000. A Nonlinear Disturbance Observer for Robotic Manipulators, *IEEE Trans on Industrial Electronics*, vol 47, No 4, August, pp 932-938.
- French, B., Thomas, L., Leathley, M., Sutton, C., McAdam, J., Forster, A., Langhorne, P., Price, C., Walker, A., Watkins, C., 2010. Does repetitive task training improve functional activity after stroke? A Cochrane systematic review and meta-analysis. *Journal of rehabilitation medicine* 42: 9-14.
- Grebenstein, G., 2010. *A Method for Hand Kinematic Designers*, ICABB, Venice, Italy.
- Housman, S.J., Scott, K.M., Reinkensmeyer, D.J., 2009. A randomized controlled trial of gravity-supported, computer-enhanced arm exercise for individuals with severe hemiparesis. *Neurorehabil Neural Repair* 23: 505-514, 2009.
- Irimia, D.C., Popescu, C.D., Poboroniuc, M.S., Ignat, B.E., Bolbocean, O., 2014. Using a Motor Imagery based-BCI system for neuroprosthesis control, *The 12th Congress of the Romanian Society of Neurology*, Bucharest, Romania, *Romanian Journal of Neurology* (8), ISSN online: 2069-6094, ISSN-L 1843-8148.
- Irimia, D.C., Ortner, R., Krausz, G., Guger, C., Poboroniuc, M., 2012. BCI Application in Robotics Control, *14th IFAC Symposium on Information Control Problems in Manufacturing*, Bucharest, Romania, 14 (1): 1-6, ISSN: 1474-6670; ISBN: 978-3-902661-98-2, DOI: 10.3182/20120523-3-RO-2023.00432.
- Kitago, T., Goldsmith, J., Harran, M., Kane, L., Berard, J., Huang, S., Ryan, S.L., Mazzoni, P., Krakauer, J.W., Huang, V.S., 2015. Robotic therapy for chronic stroke: general recovery of impairment 5 or improved task-specific skill?, *Jurnal of Neurophysiology*, 114(3):1885-94. doi: 10.1152/jn.00336.2015.
- Li, J., Wang, S., Wang, J., Zheng, R., Zhang, Y., Chen, Z., 2011. Development of a Hand Exoskeleton System for Index Finger Rehabilitation, *Chinese Journal of Mechanical Engineering* Vol. 24,aNo. 5.
- Lotti, F., Vassura, G., 2005. A Novel Approach to Mechanical Design of Articulated Fingers for Robotic Hands. *DIEM, Mech.Eng. Dept*, University of Bologna.
- Lucas, L., DiCicco, M., Matsuoka, Y., 2004. An EMG-Controlled Hand Exoskeleton for Natural, *Journal of Robotics and Mechatronics*, Vol.16 No.5, pp 1-9.
- Popescu, N., Popescu, D., Cozma, A., Vaduva, A.J., 2014. Hardware Design and Implementation of an Intelligent

- Haptic Robotic Glove, *Proc. of the the 8th International Conference and Exposition on Electrical and Power Engineering, EPE2014*, IASI Romania, ISSN: 978-1-4799-5848-1, 2014.
- Popescu, N., Popescu, D., Ivanescu, M., Popescu, D., Vladu, C., Vladu, I., 2013. Force Observer-Based Control for a Rehabilitation Hand Exoskeleton System, *Asian Control Conference (ASCC2013)*, pp. 1-6, Istanbul, Turkey.
- Popescu, N., Popescu, D., Poboroniuc, M., Popescu, C.D., 2013. Intelligent Haptic Robotic Glove for Patients Diagnosed with Cerebrovascular Accidents, *19th International Conference on Control Systems and Computer Science, Workshop on Medical and Rehabilitation Engineering Applications*, pp 717-721, October, Sinaia.
- Popescu, N., Popescu, D., Ivanescu, M., Popescu, D., Vladu, C., Berceanu, C., Poboroniuc, M., 2013. Exoskeleton Design of an Intelligent Haptic Robotic Glove, *19th International Conference on Control Systems and Computer Science*, vol. 1, pp. 196-201, Bucharest.
- Reynaerts, D., 1995. *Control methods and actuation technology for whole-hand dexterous manipulation*, .D. dissertation, Prod. Eng. Mach. Design Autom., Catholic Univ. Leuven, Leuven, Belgium.
- Rodriguez-Cheu L.E., Casals, A., 2006. Sensing and control of a prosthetic hand with myoelectric feedback, *the 1st IEEE/RAS-EMBS Int. Conf. Biomed. Robot. Biomechatron.*, Pisa, Italy.
- Xian, C., de Queiroz, M. S., Dawson, D. M., McIntyre, M. L., 2004. A Discontinuous Output Controller and Velocity Observer for Nonlinear Mechanical Systems, *Automatica*, 40, 4, April, pp. 695–700.
- Zhao, J., Xie, Z., Jiang, L., Cai, H., Liu, H., Hirzinger, G., 2006. A fivefingered underactuated prosthetic hand control scheme, *1st IEEE/RAS-EMBS Int. Conf. Biomed. Robot. Biomechatron.*, Pisa, Italy.