

# A Distributed ICT Architecture for Continuous Frequency Control

Christian Giovanelli<sup>1</sup>, Olli Kilkki<sup>1</sup>, Antti Alahäivälä<sup>1</sup>, Ilkka Seilonen<sup>1</sup>,  
Matti Lehtonen<sup>1</sup> and Valeriy Vyatkin<sup>1,2</sup>

<sup>1</sup>*School of Electrical Engineering, Department of Electrical Engineering and Automation,  
Aalto University, 02150 Espoo, Finland*

<sup>2</sup>*SRT, Luleå University of Technology, Luleå, Sweden*

**Keywords:** Smart Grid, Demand Response, Distributed ICT Architecture, Continuous Frequency Control.

**Abstract:** The active participation of consumers in frequency control can mitigate the negative effects of variable renewable generation in a power system. This study aims at designing a distributed information and communication technology architecture for automated demand response. The distributed architecture enables a set of consumers to perform frequency control while being coordinated by an aggregator. Moreover, decision-making algorithms are designed to enable the demand response to participate in frequency control and to provide required reserves. An asynchronous message-oriented middleware is utilized to interface the consumers with the aggregator. In addition, the communication logic between the actors is defined. The distributed architecture is then evaluated through the implementation of a prototype application. Simulated results show that the designed architecture can be utilized for frequency control in automated demand response.

## 1 INTRODUCTION

In electrical power systems, the supply and demand are required to be continuously in balance. Any imbalance either increases or decreases the system frequency which may endanger the system security and the continuity of electricity supply. In order to coordinate these frequency excursions, power systems utilize different frequency control processes. In the Nordic power system, the first control process to react to the frequency oscillations is called frequency containment process. Its tasks are to maintain the balance in time frame of seconds and to stabilize the system frequency after disturbances (Entsoe, 2015). Thus, the process has a crucial role in the frequency coordination. The process activates two types of reserves in the considered Nordic power system: frequency containment reserves for normal operation (FCR-N), and frequency containment reserves for disturbance (FCR-D) (Fingrid, 2016).

Due to the expansion of variable renewable in the power supply, the frequency containment is becoming increasingly challenging. For this reason, it is important to identify new solutions for the frequency containment, which are not relying only on the supply. One such a solution is to employ electricity consumption in the frequency containment process (Siano, 2014). In particular, the Demand Response

(DR) could contribute to provide the required reserves by shaping the electricity consumption (Short et al., 2007). In fact, a large number of consumers provided with intelligent electronic devices (IED), capable of shaping and shifting their load, could take part in the DR. However, the involvement of consumers in the frequency control process would require an increasing quantity of information exchange, which would demand improvements to the current information and communication technologies (ICT) infrastructure of the power grid.

ICT systems will be among the key elements that will drive the enhancement of the future power grid (Gungor et al., 2013). ICT systems could provide the necessary communication infrastructure, information technologies, and applications for an improved power delivery. Among others, ICT systems enabling consumers to participate in DR would be needed to ensure better coordination and decision-making for the distributed resources. These architectures are required to be reliable, flexible, and scalable. Thus, internet-based architectures, such as service-oriented (Grijalva and Tariq, 2011) and cloud-based (Kim et al., 2010), have been identified as possible driver technologies for modernizing the current power grid.

The aim of this paper is to design a distributed ICT architecture and an application logic capable of performing automated demand response (ADR) for

continuous frequency control (CFC) of FCR-N. The architecture consist of an aggregator and a set of consumers that are communicating in order to perform ADR for CFC. The communication is based on an asynchronous Message-oriented Middleware (MOM) that interfaces all the participants of the ADR. In addition, the aggregator utilizes a specifically designed algorithm to allocate the DR instructions that consumers have to adhere based on the frequency variations in the grid. To evaluate the ICT architecture and the MOM, a set of scenarios are simulated. These simulations verify the feasibility of the architecture and validate that the MOM can be utilized for CFC.

The remainder of the paper is organized as follows. Section 2 introduces the related work. Then, Section 3 presents the requirements of the ADR system, after which Section IV details the design of the ADR architecture, focusing on both decision-making algorithms and communication logic. In Section 5, simulation results are presented, and in Section 6 the discussion. The final section then draws conclusions.

## 2 RELATED WORK

The control of FCR-N is conventionally implemented in a decentralized manner by a droop control, i.e., generation plants adjust their output in proportion to the system frequency. However, the growing penetration of variable renewable generation, which is replacing the conventional generation (Lalor et al., 2005) and the increase of reserve requirements (Halamay et al., 2011), are threatening the stability of the electrical grid. New strategies for CFC could consider the demand-side for balancing the system frequency (Short et al., 2007). Consumers could be involved in ADR for CFC by controlling domestic appliances based on the system frequency (Samarakoon et al., 2012). Examples of such appliances are HVAC, refrigerators (Angeli and Kountouriotis, 2012), energy storage devices (Megel et al., 2013), and electrical vehicles (EVs) (Masuta and Yokoyama, 2012).

Control algorithms are required to provide decision-making capabilities for enabling the participation of the consumers in the DR. Various control strategies have been designed for performing CFC (Xu et al., 2011). Control strategies for CFC that do not require a two-way communication and a central coordination have been proposed (Molina-Garcia et al., 2011). On the other hand, decision-making algorithms have been designed in which an aggregator coordinates the consumers during their participation in the DR for CFC (Pourmousavi and Nehrir, 2012), (Vrettos et al., 2014). The advantage of the latter solu-

tions consists of the possibility to coordinate the provided reserves of the ADR system. This advantage becomes important in the case where the provided reserves have to be agreed beforehand, during DR planning phases such as day-ahead and intra-day market. However, the aggregated coordination of consumers require the development of new ICT technologies.

The future smart grid will be interdependent with its ICT architecture (Yan et al., 2013). Currently, ICT architectures for smart grids are in an initial stage of development (Zaballos et al., 2011). In fact, various technologies need to be developed in order to enhance the current ICT architecture (Fang et al., 2012). Among others, service-oriented middleware for smart grid have been proposed to have a central role in the ICT architectures (Rodrigues, 2013). Service-oriented middleware acts as a broker among many heterogeneous entities which are communicating in the smart grid. Considering ADR for CFC, communication represents an important component for making various heterogeneous entities collaborating together (Kilkki et al., 2014). Nevertheless, ICT architectures enabling CFC should be further explored to enhance the distributed control and the communication between consumers and service providers.

## 3 REQUIREMENTS

The design of the ADR system defined in this study needs to fulfill a set of requirements. The main requirement is that the ADR architecture is capable of performing CFC. The ADR architecture is required to implement one aggregator and a set of consumers that are collaborating together in order to execute CFC. In addition, in order to define an ADR architecture for CFC, several other requirements have to be met. The following requirements can be categorized in electrotechnical requirements, communication requirements and system requirements.

To participate in CFC and provide FCR-N, the ADR system should fulfill certain electrotechnical requirements established by the transmission system operator (TSO). This is to say that the ADR system is expected to perform according to these electrotechnical requirements. In the Nordic power system, for the case of FCR-N, the reserve should be fully available within three minutes after a step change of  $\pm 0.1$  Hz from the nominal frequency, while a maximum dead-band of  $\pm 0.05$  Hz is allowed (Fingrid, 2016). The reserves are not expected to react if the frequency is within the dead-band. The amount of provided reserve is the activated power after three minutes against the step change. In this study, the

minimum provided reserve size (0.1 MW) by a resource owner is not considered, nor any possible frequency measurement errors.

Communication requirements have been identified for the ADR system for CFC. The communication between the actors needs to allow the ADR system to perform CFC. Due to the electrical requirement of having the reserve active within three minutes, the communication should be able to work under these near real-time constraints. In addition, the communication should support interoperability between the actors, which should interact by means of a predefined format of data exchange. The communication should also prove to be scalable up to several thousands of consumers. Furthermore, the communication should be reliable and secure.

The system requirements define the composition of the system. The ADR system is composed of two main actors: an aggregator and a set of consumers. The aggregator acts as a mediator between consumers and the utility operator (Gkatzikis et al., 2013). By interfacing with the consumers participating in the ADR, the aggregator has an obvious advantage to have the complete overview of the entire system. For this reason, the aggregator is required to implement a decision-making algorithm capable of coordinating the policies and allocating the reactions that each consumer has to observe for performing CFC.

Consumers represent the second set of actors in the ADR system. The ADR system is required to have several thousands of consumers which take part in the CFC by reacting to the frequency deviations from the nominal frequency. Each consumer has to own IED devices that can be used for CFC. Examples of such IED devices are refrigerators, HVACs and EVs. In addition, consumers are required to be equipped with an energy management system (EMS) (Siano, 2014). The EMS is a IED gateway device capable of interfacing with the various IED devices in the home area network (HAN). Another functionality of the EMS is to interface the household with the cloud-based system for ADR via an IP-based protocol. Moreover, for executing CFC, the EMS needs to be able to measure the frequency of the power grid.

## 4 DESIGN

### 4.1 ADR System Design

As can be seen from the Figure 1, the ADR system is composed by three main components: a software system with a cloud-based architecture, an electrical grid, and a set of consumers' households. The cloud-based

system implements the necessary applications for executing the ADR for CFC. Moreover, the electrical power grid provides electricity to the consumers' households which can then measure the frequency through the EMS. The households are equipped with the EMS that is interfacing within the HAN with a set of IED devices capable of CFC, and through the WAN with the cloud-based system.

The cloud-based system for CFC implements two main applications: the Aggregator and the DR Consumer. The Aggregator application performs the required functionalities requested from the aggregator (Gkatzikis et al., 2013). On the other hand, each consumer has one instance of the DR Consumer application. The DR Consumer application provides services to the consumers for ADR which spans from energy forecasting, optimization and CFC decision-making. Moreover, the intra-cloud communication between different applications is performed by an asynchronous message oriented middleware (MOM).

The MOM is based on the Advanced Message Queue Protocol (AMQP, 2016). AMQP provides asynchronous message-oriented queuing communication, and it is capable of advanced routing messaging. Among others, AMQP supports both publish-subscribe and request-response communication. The AMQP MOM provides several features which are of fundamental importance to fulfill the communication requirements of the ADR system. In fact, the AMQP MOM supports the scalability of the communication between applications. Moreover, the AMQP MOM ensures that the various applications in the intra-cloud system are decoupled. In addition, the AMQP MOM offers a reliable and secure communication protocol.

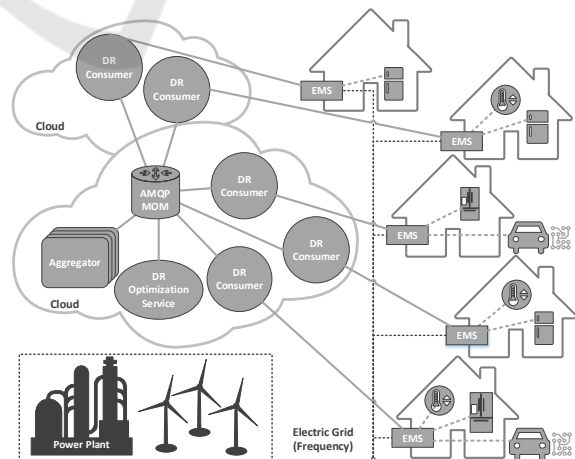

Figure 1: Overview of the ADR system for continuous frequency control.

## 4.2 Decision-making Algorithms

To perform CFC, two main decision-making algorithms have been implemented in the ADR system. Firstly, a decision-making algorithm is executed by each consumer. The algorithm establishes whether a consumer participates in the CFC, and whether the consumer reacts to over-frequency, under-frequency, or both situations. This allows each consumer to be independent in the decision of participating in the CFC, based on their capabilities. The aggregator is then executing the second decision-making algorithm, in which an allocation algorithm schedules the CFC reactions of the consumers, and provides the required coordination for provisioning the reserves.

### 4.2.1 Consumer Participation Algorithm

Consumers participate in the CFC by either increase or decrease their consumption. Each consumer can decide whether or not to take part in the CFC through the execution of the consumer participation algorithm. This decision-making algorithm is implemented in the DR Consumer application, which, by knowing the status of the IED devices in the household, estimates two time based parameters called Participation Time (PT) and Reaction Time (RT). These two parameters are then used to decide whether the consumer has the capability of providing reserves.

Figure 2 shows how PT and RT are calculated from a thermodynamic load. Typically, in a thermodynamic load the controlled variable has to stay between defined upper ( $T_{MAX}$ ) and lower bound ( $T_{MIN}$ ) limits. Given the current thermal status ( $T_{CTS}$ ) of the controlled variable, it is possible to project the status to the respective boundaries in order to calculate the two parameters. As an example, assuming that Figure 2 represents the thermodynamic status of a refrigerator as presented in (Stadler et al., 2009), the following equations show how PT and RT can be calculated for such a case:

$$PT = -\frac{1}{\tau} \ln\left(\frac{T_{MAX} - T_{AMB} + \eta \frac{ptcl}{A}}{T_{CTS} - T_{AMB} + \eta \frac{ptcl}{A}}\right) \quad (1)$$

$$RT = -\frac{1}{\tau} \ln\left(\frac{T_{MIN} - T_{AMB} + \eta \frac{ptcl}{A}}{T_{CTS} - T_{AMB} + \eta \frac{ptcl}{A}}\right) \quad (2)$$

where  $\tau$  is a time constant,  $T_{AMB}$  represents the external ambient temperature,  $\eta$  is a coefficient of performance,  $ptcl$  consists in the rated power ( $W$ ) of the appliance, and  $A$  represents the thermal conductance ( $W/^\circ C$ ). Besides the refrigerators, this example can be applied to several types of thermal loads such as HVAC and water boilers.

The parameters, estimated by the Consumer Participation Algorithm, are of fundamental importance for the aggregator which, through a decision-making algorithm called Frequency Allocation Algorithm (FAA), will use these parameters to decide the policies that each consumer will have to follow. In fact, PT represents the time in which the consumer has the capability of participating in the ADR, while RT defines for how long the consumer can react to a frequency deviation. The DR Consumer has to define the participation and the reaction time for both: the over-frequency and the under-frequency. Based on the participation and the reaction time, each consumer decides whether or not it is possible to take part in the CFC, and then sends the decision to the aggregator. Currently, the decision on the participation is based on defined thresholds for PT and RT, which are both required to be more than a certain threshold value of 5 minutes.

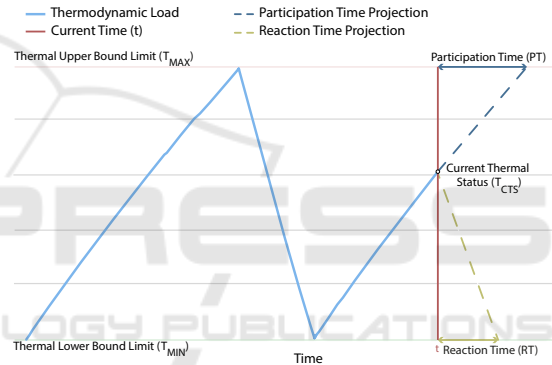

Figure 2: An example of a thermodynamic load with thermal boundary limits. The participation and reaction times are estimated by projecting the current thermal status to the upper and lower boundary.

### 4.2.2 Frequency Allocation Algorithm

The FAA is executed by the aggregator. The algorithm aims to define the policies that each consumer will have to follow to participate in the CFC and react to the frequency deviation in the power grid. Based on the latest updates received from the Consumer Participation Algorithms of each consumer, the FAA elaborates the policies by allocating the CFC reactions in the form of instruction messages for the consumers. If FAA selects one consumer for the CFC, the respective instruction message will contain the frequency threshold from which the consumer should start reacting, and provide accordingly the promised reserve.

Algorithm 1 provides the pseudocode of the FAA. The algorithm starts with the procedure *IsUpdate-Needed*. This procedure establishes whether a new update of the consumer instructions is needed based

on two criteria. The first criteria is based on a timeout of several minutes after which the CFC reactions are required to be reallocated. In addition, the second criteria decides whether a new update is needed before the expiring of the aforementioned timeout. In fact, if a quota of the allocated consumers updates the aggregator declaring their inability to continue providing the allocated reserves, then a new update of the consumer instructions is executed.

The FAA begins by retrieving the latest update messages of each consumer through the *GetLatestUserUpdates* procedure. Then, the algorithm proceeds by allocating in sequence the under-frequencies and the over-frequencies to the consumers based on the updates received. The algorithm ranks the best consumer for CFC through the *OrderByUnderFrequency* and the *OrderByOverFrequency* procedures, which order the consumers respectively for the under-frequencies and the over-frequencies. These two procedures order the consumers according to their ability to perform CFC. The ordering is performed based on the PT, the RT and an aging parameter, which are sent from each consumer to the aggregator. While the PT and the RT are estimated by the DR Consumers, the aging parameter represents the number of times that each consumer have acted to the CFC, and it is used during the ordering to avoid overloading only a small set of consumers with many CFC reactions. The ordering, for both under-frequency and over-frequency, gives the priority to the consumers with higher PT and RT, and a smaller aging parameter.

Following the procedures of ordering the consumers, the *AllocateUnderFrequency* and *AllocateOverFrequency* procedures are used to allocate the reaction frequencies to the consumers according to the given ranking in the ordering. The FAA allocates the frequencies for CFC reaction until the CFC reaction of the ADR system can cover the required target reserves. Finally, the algorithm proceeds to send the new instructions to the consumers through the *SendInstructionsToConsumers* procedure.

### 4.3 Communication Logic

The communication logic of the ADR system can be divided in two phases: the status update phase and the instruction phase. These phases are asynchronous between each other. The status update phase is used by the consumers to provide the last updates to the aggregator, while the instruction phase is used by the aggregator to update the consumers with new policies for the CFC.

---

#### Algorithm 1: Frequency Allocation Algorithm.

---

```

1: function FREQUENCYALLOCATION
2:   loop
3:     ▷ // Checks if a new update is needed
4:     if IsUpdateNeeded() then
5:       GetLatestUserUpdates()
6:       ▷ // Under Frequency Allocation
7:       OrderByUnderFrequency()
8:       AllocateUnderFrequency()
9:       ▷ // Over Frequency Allocation
10:      OrderByOverFrequency()
11:      AllocateOverFrequency()
12:      ▷ // Send instructions to Consumers
13:      SendInstructionsToConsumers()

```

---

#### 4.3.1 Status Update Phase

The status update phase consists of all the necessary communication steps needed by the consumers to notify the aggregator about their possibility to participate in the ADR for CFC. Figure 3 shows the sequence diagram of the update phase. Before detailing the communication logic, it is important to note that the messages exchanged between each actor during the update phase are asynchronous.

The update phase starts with each IED device that sends status update messages to the respective EMS. The EMS operates as a network gateway by interfacing with various IED devices using different protocols within the HAN. After processing the data of the IED devices, the EMS sends a message containing the information of the IED devices that can be used for CFC to the DR Consumer. Then, the DR Consumer aggregates the provided data and establishes whether or not the consumer could participate in the CFC, either to the over-frequency, the under-frequency or both the controls. In the last step, the DR Consumer updates the aggregator, with a *Frequency Control S-U* message, about its capability in participating to the CFC.

#### 4.3.2 Instruction Phase

The second phase of the communication logic is called instruction phase. During this phase, the aggregator sends the necessary instructions to the consumers, enabling their participation to the CFC. In the FAA, as shown in Algorithm 1, the aggregator starts by calling the *SendInstructionsToConsumers* procedure. Figure 4 presents the sequence diagram of the communication logic for the instruction phase.

The aggregator starts the instruction phase as the last task in the execution of the FAA. The algorithm determines the set of consumers that will be involved

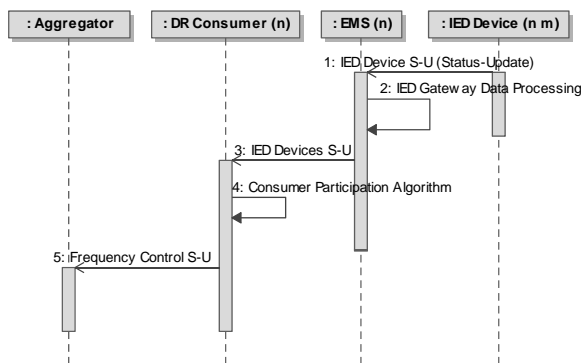

Figure 3: A sequence diagram showing the update phase of the CFC communication logic.

in the CFC. Whereupon, the aggregator sends an *Instruction Message* to each DR Consumers which contains the instructions needed to react to the CFC. If the consumer has to use multiple IED devices for CFC, the DR Consumer disaggregates the instructions of the aggregator, and allocates them to each different IED device. Then, the DR Consumer sends an *IED Control Instruction* message to the EMS which contains the control instructions scheduled for the IED devices. The EMS, when instructed to apply CFC, measures the frequency of the electric grid, and it reacts following the provided instructions. When the frequency exceeds the given limits, the EMS sends a DR Reaction Control message to the IED devices involved, which are then participating to the CFC.

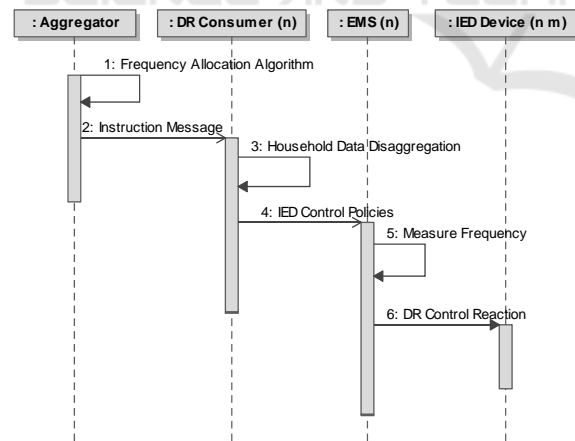

Figure 4: A sequence diagram that shows the communication logic of the instruction phase of the ADR system for CFC.

## 5 EXPERIMENTATION

The ADR system was evaluated through simulations based on a prototype application. The prototype ap-

plication has been developed using Java. The prototype application is composed of different entities: one Aggregator application, a set of DR Consumer applications, and a RabbitMQ MOM (RabbitMQ, 2016) which relies on the AMQP protocol. For each consumer, the DR Consumer application is interfaced with the respective EMS. The EMS model provides the interconnection with the IED devices of the household. The IED devices of each consumer are modeled as refrigerators, which will be utilized by the consumers to participate in the ADR for CFC. The refrigerator population is based on the models presented in (Stadler et al., 2009). Moreover, end-to-end communication delays were injected into the ADR system and uniformly distributed between 1 and 3 seconds.

For the following simulations, various types of data were utilized. The frequency data were taken from different sources. The first set of the frequency data was defined manually with some ad hoc patterns, while the second set consists of real frequency data (Mainsfrequency, 2012). The number of consumers utilized was 5000. The aggregator target reserves was 40kW for both the over-frequency and the under-frequency (de la Torre Rodriguez et al., 2014). The maximum deviation from the nominal frequency in which the reserves were fully activated was +/- 0.1 Hz, while the dead-band specified was +/- 0.02 Hz. Moreover, the system frequency dynamics were not affected by the simulated system, since the controlled power was relatively low.

In order to verify that the ADR system is capable of performing CFC, simulations were executed. Figure 5 presents one hour simulation of the developed prototype application for the ADR system in which CFC is performed. Based on the frequency deviation from the nominal value (50 Hz), the ADR system was reacting by providing the necessary reserves. The aggregated consumption shows how the consumers of the ADR system were reacting to the frequency changes of the electrical grid. Again, the estimated nominal consumption shows instead the estimated consumption of the system without being involved in the CFC. The deviation between the aggregated consumption and the estimated nominal consumption represent the amount of reserves that the ADR system for CFC was able to provide. Lastly, the vertical dashed lines represent the times in which the aggregator starts updating the consumers after executing the FAA through the instruction phase.

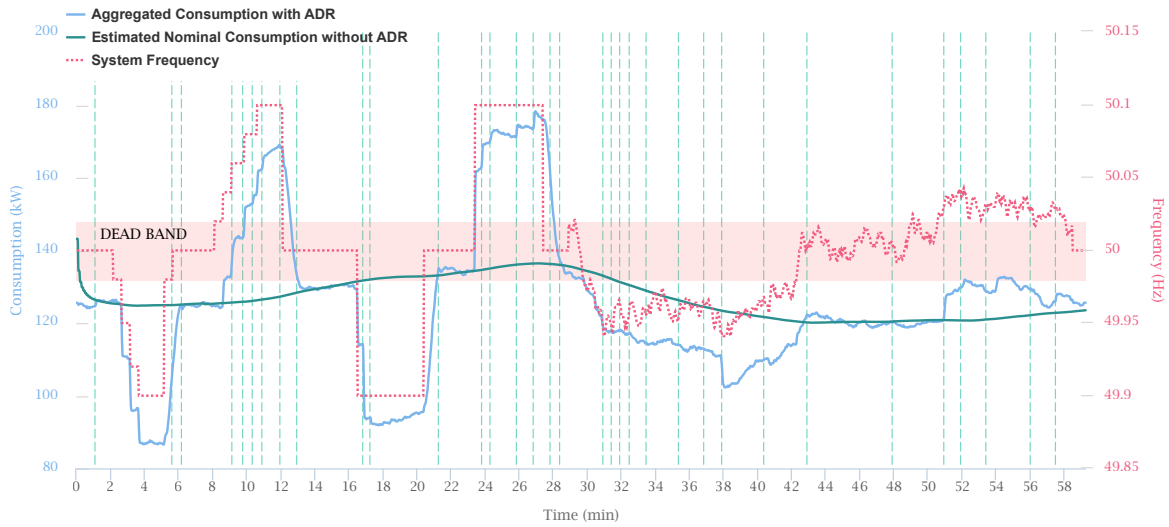

Figure 5: One hour simulation of the ADR system for CFC. The aggregated consumption of the ADR system reacts to the frequency changes of the system by providing the allocated reserves by the frequency allocation algorithm.

## 6 DISCUSSION

As shown in Figure 5, the ADR system performs CFC by reacting to the frequency changes in the electrical grid and providing the necessary reserves. Currently, consumers are using a heterogeneous population of fridges to apply CFC. Adding more heterogeneity to the system (i.e. by adding populations of different IED devices for CFC as HVAC or EVs) as well as increasing the number of consumers could provide both a more realistic scenario and improve the quality of the simulation results. This addition would probably not have a big impact in the communication of the ADR system. On the other hand, it would affect both the decision-making algorithms, which would increase in complexity.

The decision-making algorithms defined in this study have proved to have a key role in the ADR architecture. Undoubtedly, the FAA has resulted to have a fundamental role in the decision-making process which enables the ADR system to perform CFC. The current disadvantage of this algorithm consists in the fact of being centralized and executed by a single entity as the aggregator. Thus, a possible improvement would be to redefine the algorithm in a fully distributed way, in which the aggregator could specify the objectives (e.g. in term of reserves) that the ADR system should achieve, while the consumers altogether could negotiate the CFC reactions needed to fulfill the specified objectives. In addition, the participation of the consumers in the CFC is currently based only on the two parameters PT and RT. An improvement of the consumer participation algorithm could

include user preferences as a key factor for deciding whether a consumer can participate to the CFC.

Compared to the previous study (Giovannelli et al., 2016), in which the communication was used for an energy consumption planning phase with no time constraints, the current communication had to deal with near real-time constraints. This constraint was due to the electrical requirement of having the reserves fully available within three minutes. This additional constraint has allowed to further stretch the asynchronous MOM, which has resulted to well perform also in the presented new scenario.

## 7 CONCLUSIONS

This paper presented a prototype of ADR system capable of performing CFC. A set of consumers was communicating with an aggregator in order to provide the required reserves during events of frequency deviations. For the intra-cloud communication, an asynchronous MOM was utilized to interface the consumers with the aggregator. Moreover, two decision-making algorithms were defined to enable the consumers to participate in the CFC. Finally, the capability of the ADR system to provide CFC was evaluated based on simulations with real data.

Future research might explore the possibility of improving the decision-making algorithm for frequency allocation. A further study could enhance the FAA by supporting different IEDs and exploiting their different properties. Moreover, a distributed solution for the FAA could further enhance the ADR system.

In fact, a distributed algorithm could provide a more robust and reliable solution.

## ACKNOWLEDGEMENTS

This research has been funded by the SAGA project of the Aalto Energy Efficiency (AEF) Research Program and the Flexible Customer project funded by the Academy of Finland.

## REFERENCES

- AMQP (2016). Amqp web page, <https://www.amqp.org/>.
- Angeli, D. and Kountouriotis, P.-A. (2012). A Stochastic Approach to Dynamic-Demand Refrigerator Control. *IEEE Transactions on Control Systems Technology*, 20(3):581–592.
- de la Torre Rodriguez, M., Scherer, M., Whitley, D., and Reyer, F. (2014). Frequency containment reserves dimensioning and target performance in the European power system. In *2014 IEEE PES General Meeting — Conference & Exposition*, pages 1–5. IEEE.
- Entsoe (2015). Supporting document for the network code on load-frequency control and reserves.
- Fang, X., Misra, S., Xue, G., and Yang, D. (2012). Smart grid: the new and improved power grid: A survey. *IEEE communications surveys & tutorials*, 14(4):944–980.
- Fingrid (2016). Fingrid web page, <http://www.fingrid.fi/en/pages/default.aspx>.
- Giovanelli, C., Kilkki, O., Seilonen, I., and Vyatkin, V. (2016). Distributed ict architecture and an application for optimized automated demand response. In *IEEE PES ISGT Europe 2016*. IEEE.
- Gkatzikis, L., Koutsopoulos, I., and Salonidis, T. (2013). The role of aggregators in smart grid demand response markets. *IEEE Journal on Selected Areas in Communications*, 31(7):1247–1257.
- Grijalva, S. and Tariq, M. U. (2011). Prosumer-based smart grid architecture enables a flat, sustainable electricity industry. In *ISGT 2011*, pages 1–6. IEEE.
- Gungor, V. C., Sahin, D., Kocak, T., Ergut, S., Buccella, C., Cecati, C., and Hancke, G. P. (2013). A Survey on Smart Grid Potential Applications and Communication Requirements. *IEEE Transactions on Industrial Informatics*, 9(1):28–42.
- Halamay, D. A., Brekken, T. K. A., Simmons, A., and McArthur, S. (2011). Reserve Requirement Impacts of Large-Scale Integration of Wind, Solar, and Ocean Wave Power Generation. *IEEE Transactions on Sustainable Energy*, 2(3):321–328.
- Kilkki, O., Kangasrääsio, A., Nikkilä, R., Alahäivälä, A., and Seilonen, I. (2014). Agent-based modeling and simulation of a smart grid: A case study of communication effects on frequency control. *Engineering Applications of Artificial Intelligence*, 33:91–98.
- Kim, Y.-J., Thottan, M., Kolesnikov, V., and Lee, W. (2010). A secure decentralized data-centric information infrastructure for smart grid. *IEEE Communications Magazine*, 48(11):58–65.
- Lalor, G., Mullane, A., and O’Malley, M. (2005). Frequency Control and Wind Turbine Technologies. *IEEE Transactions on Power Systems*, 20(4):1905–1913.
- Mainsfrequency (2012). Mainsfrequency web page, <http://www.mainsfrequency.com/services.htm>.
- Masuta, T. and Yokoyama, A. (2012). Supplementary load frequency control by use of a number of both electric vehicles and heat pump water heaters. *IEEE Transactions on Smart Grid*, 3(3):1253–1262.
- Megel, O., Mathieu, J. L., and Andersson, G. (2013). Maximizing the potential of energy storage to provide fast frequency control. In *IEEE PES ISGT Europe 2013*, pages 1–5. IEEE.
- Molina-Garcia, A., Bouffard, F., and Kirschen, D. S. (2011). Decentralized demand-side contribution to primary frequency control. *IEEE Transactions on Power Systems*, 26(1):411–419.
- Pourmousavi, S. A. and Nehrir, M. H. (2012). Real-Time Central Demand Response for Primary Frequency Regulation in Microgrids. *IEEE Transactions on Smart Grid*, 3(4):1988–1996.
- RabbitMQ (2016). Rabbimq web page, <https://www.rabbitmq.com/>.
- Rodrigues, J. (2013). Service-oriented middleware for smart grid: Principle, infrastructure, and application. *IEEE Communications Magazine*, 51(1):84–89.
- Samarakoon, K., Ekanayake, J., and Jenkins, N. (2012). Investigation of Domestic Load Control to Provide Primary Frequency Response Using Smart Meters. *IEEE Transactions on Smart Grid*, 3(1):282–292.
- Short, J. A., Infield, D. G., and Freris, L. L. (2007). Stabilization of Grid Frequency Through Dynamic Demand Control. *IEEE Transactions on Power Systems*, 22(3):1284–1293.
- Siano, P. (2014). Demand response and smart grids: A survey. *Renewable and Sustainable Energy Reviews*, 30:461–478.
- Stadler, M., Krause, W., Sonnenschein, M., and Vogel, U. (2009). Modelling and evaluation of control schemes for enhancing load shift of electricity demand for cooling devices. *Environmental Modelling & Software*, 24(2):285–295.
- Vrettos, E., Oldewurtel, F., Zhu, F., and Andersson, G. (2014). Robust Provision of Frequency Reserves by Office Building Aggregations. *IFAC Proceedings Volumes*, 47(3):12068–12073.
- Xu, Z., Ostergaard, J., and Togeby, M. (2011). Demand as Frequency Controlled Reserve. *IEEE Transactions on Power Systems*, 26(3):1062–1071.
- Yan, Y., Qian, Y., Sharif, H., and Tipper, D. (2013). A survey on smart grid communication infrastructures: Motivations, requirements and challenges. *IEEE communications surveys & tutorials*, 15(1):5–20.
- Zaballos, A., Vallejo, A., and Selga, J. M. (2011). Heterogeneous communication architecture for the smart grid. *IEEE Network*, 25(5):30–37.