

***In Vitro* Test Bench with Intelligent Behavior to Ventricular Assist Devices**

Jeferson Cerqueira Dias¹, Jônatas Cerqueira Dias¹, Marcelo Barbosa¹, Diolino José Santos Filho¹,
Fabrício Junqueira¹, Paulo Eigi Miyagi¹, Jose Roberto Cardoso²

¹*Department of Mechatronics Engineering and Mechanic Systems,
University of São Paulo - USP, Prof. Luciano Gualberto Avenue, 380, São Paulo, Brazil*

²*Department of Energy Engineering and Electrical Automation,
University of São Paulo - USP, Prof. Luciano Gualberto Avenue, 380, São Paulo, Brazil*

Keywords: Intelligent Behavior, Test Bench, Ventricular Assist Device, Reliability, *In Vitro* Test.

Abstract: The abstract The Ventricular Assist Device (VAD) is a mechatronic device used to treat patients with heart failure who are able to use them in short- and long-term strategies. However, with increasing population longevity, long-term use has been intensified. Thus, the development of resources that improve the robustness and reliability of these devices is justified. This work proposes an *in vitro* test bench with intelligent behaviour that through a systematic of protocols for the collection, treatment and monitoring of reliability data, coming from standard curves of monitored variables, such as: flow, pressure, vibration, rotation, density, viscosity and temperature, provides a decision support system with user friendly interface for verification, validation and certification of VAD. The proposed method is descriptive of an *in vitro* test bed model for VAD that considers the use of Petri net for validation of the dynamic behaviour in front of the variables and a decision support system based on big data analytics technology with extraction of data, which subsidizes intelligent behaviour. The proposed model is consistent with the bibliographic base and its validation. The Petri net allows confirming its application in the decision making, with intelligent behaviour, from the data mining.

1 INTRODUCTION

In the last twenty years we have witnessed a technological evolution in the development of products and processes, from consumer goods to industrial automation systems. One of the most determining characteristics observed in this evolution is artificial intelligence, although there is no common definition among researchers. We can describe intelligence as the ability to understand events in the surrounding environment and to process information rationally in order to react to events in this environment (Flynn, 2009; Khalifa, 1995).

Over the years, this characteristic has been moving towards consumer products, something perceived in 1991 by Mark Weiser, considered the forerunner of ubiquitous computing, of which technology is present everywhere (present in objects such as clothing labels, switches, pens, among others), but it is transparent to the user (Weiser, 1991). These technologies enable physical products

to be filled with intelligence, sensitivity, and communication skills. This creates a new product category called "Smart Products" (Mühlhäuser, 2007; Sharma, et al., 2017; Kuhn et al., 2018) that is, systems that behave rationally (Russell; Norvig, 2013).

This evolution is based on the microelectronics with the recent innovations in microchips, allowing to create smaller sensors that through computers, control actuators, allowing, thus, to create mechanisms of intelligent mechatronic systems.

The development of mechatronic devices encompasses the design that combines: mechanical structures with electronic control circuits (Silva, 2005). Over the years, these devices have become smarter, utilizing optical resources, renewable energy, computer science, automated control and other disciplines, as well as new software technologies, internet of things (IoT), robotics and manufacturing integrated by computer (Atoche and Marrufo, 2011).

This article proposes the use of this technological evolution in the study of Ventricular Assist Devices (VAD), since according to the World Health Organization in 2016 of the 38 million deaths per year, classified as "non-transmissible", 17.5 million (46%) were cardiovascular diseases. Of these, 7.4 million were coronary heart disease and 6.7 million strokes (World Health Organization, 2016) and a growth of more than 23.6 million of these diseases is planned for 2030 (Mozaffarian et al., 2016). Cardiovascular mortality rates remain the leading cause of death worldwide (Nichols et al., 2015).

The implantation of a VAD has proven to be a successful option for the treatment of patients with heart failure, that is, it can be implanted to ensure that the patient can wait until a heart transplant, and in this case, this practice is known as "a bridge to the transplant", or when the patient has a high rejection rate for the transplant, the device is implanted as a permanent solution and in this case this practice is known as "destiny therapy" (Murala and Si, 2017) (Healy et al., 2016) (Drakos et al., 2010). One of the issues that has intensified the use of these devices as target therapy is the imbalance between the number of donors and the number of recipients for heart transplantation (Christie et al., 2012).

The increasing longevity of patients transplanted with VADs as a target therapy recently (Goldstein et al., 2018) (Cowger et al., 2018) justifies the development of features that improve the robustness and reliability of these devices. In this sense, there are several approaches that can be used for implantable medical devices, ISO standards, ASTM standards, in vivo animal study, cadaver study, among others, as well as specific methods such as the characterization and demonstration of reliability (Zhang; Jiang, 2017). Guidelines for validation procedures have also been developed for the reliable procedure for validating medical devices. The accelerated tests used as tools to verify the correctness of the manufacturing of electronic components and microelectronics are a good option to obtain and prove reliability data (Valis; Vintr; Koucky, 2010) (Evans; Sinha, 2018).

For ventricular assist devices some research has been developed, such as the use of an in vitro hemolysis test bench for development evaluation and safety regulation to check the hemocompatibility of medical devices such as VADs that have contact with blood (Olia et al., 2017). To model the arterial and pulmonary hemodynamic behavior of the circulatory system was developed by (Mueller et al., 2017) a bench of tests that presented good results for reproduction of

the system. For a total heart without valves, compatible with pediatric population, was presented by (Tozzi et al. 2017) a bench of tests that presented encouraging results, despite issues related to durability, and the need for confirmation of results with in vivo test. The bench test to simulate in vitro conditions of biomedical metal alloys for implants of devices made by (Ijaz et al., 2017) demonstrated satisfactory results for fatigue resistance of Ti-Nb-Zr alloys when compared with Ti alloys.

Improving the reliability of VADs allows a constant search, however, the absence of failure data from the device or its components for a performance analysis is a gap that can be improved with an in vitro test bed of VADs. This work within a control hierarchy proposes the testing and monitoring of devices with a continuous collection of context data, which will be analyzed and treated against reference correlation curves of variables (pressure, flow, vibration, temperature, viscosity, density, rotation, and power) that will allow us to identify the description of the occurrence of failures from which the system transfers the information to a cloud knowledge base for analysis of standards according to Big Data Analytics technologies. With this information an intelligent module based in Artificial Intelligence (AI) can readjust the set-up variables by adjusting the control to a safe state of operational functionality. Allied to this system a remote operator, with support for decision making, can also monitor and analyze the level of system failure and operate from a smart device.

In this prospective work will be used the modeling of an in vitro test bench for VAD in Petri net to represent its behavior and for validation of the model.

2 TEST BENCH

This work's proposed test bench is composed by two tanks (T1 and T2) that are responsible for the storage of the fluid that travels through the system. The fluid is transported from tank T1 to tank T2. The transport is carried out from a pump (B1), which imposes energy on the system. During the test bench operation process, sensors are used to collect the main variables involved in the system (Figure 1).

Sensors collect fluid pressure at tank outlet T1, engine speed M1 from pump B1, pump vibration B1, electric motor current M1 from pump B1, fluid pressure at pump outlet B1, fluid flow at outlet of the pump B1, the temperature of the fluid at the outlet of the pump B1, the position of the motor M2

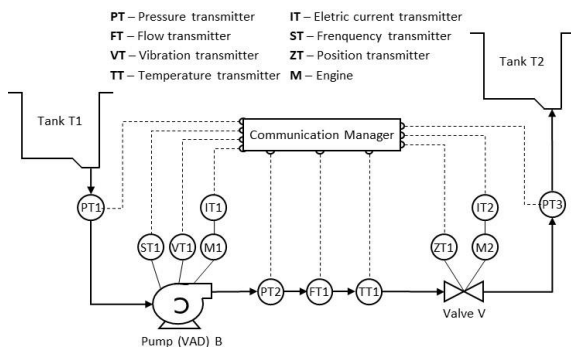

Figure 1: VAD In vitro Test Bench Process Diagram and Instrumentation.

of the valve V1, the electric current in the motor M2 of the valve V1 and the pressure of the fluid at the inlet of the tank T2.

To perform, the test bench has an M1 motor responsible for the rotation control of the pump B1 and an M2 motor responsible for the position control of the valve V1 that allows the flow control of the fluid. To collect the data emitted by the sensors and impose the new references to the actuators, a communication manager is necessary for distribution of the information.

3 PROPOSED CONTROL SYSTEM

In the development of the proposed control system, it is approached the concept that the test bench does not have an on-board control and monitoring system. In this way, the control system acts on a remote server that collects information from the test bench sensors for monitoring information on mobile / desktop devices.

The information that travels from the test bench to the supervision is carried out from the concept of Publish / Subscribe (Sonawala *et al*, 2017). This communication approach is characterized by the asynchronous exchange of events between devices and applications that make up the system, so the applications need to receive a certain type of event subscribers that is originated by another application and event publisher. The main characteristics of publish / subscribe communication are to eliminate the direct coupling between the applications and to allow the selective dissemination of information based on the interests of the system (Lopes, Bock and Gómez, 2017).

The actuating commands for parameterization of the Set Ups, the motor rotation (M1) of the pump

(B2) and the position of the motor (M2) of the valve (V1) are performed by two agents: a) from a mobile / desktop, in this case the user interferes directly in the event management and b) by the AI module, which searches through the learning and the patterns identified by the Big Data Analytics module, the best conditions of Set Up of the control variables to allow the greater life of devices (VADs) under test.

The information system performs all demand processing to inform the local communication manager that replicates the data to the local control system reference. For monitoring, the communication manager is responsible for reading the data emitted by the sensors from the test bench and publishing them from the physical event manager to the collection and storage processes in the database.

To access information about test bench operation, users can: require the performance and requests data directly from the user interface, request query information from the Big Data Analytics and AI modules, and *in vitro* make operational decisions through the mobile / desktop module (Figure 2).

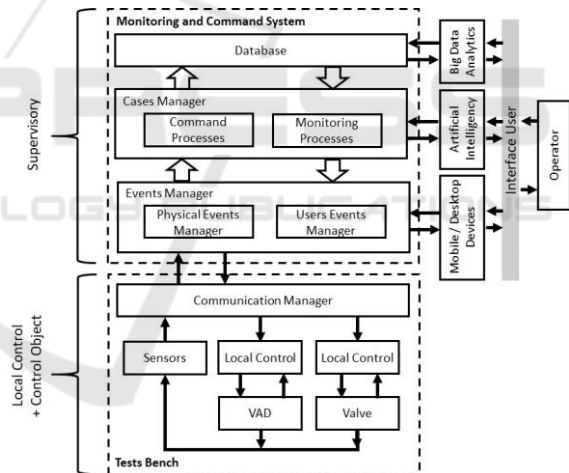

Figure 2: Architecture of proposed control.

All collection, storage, monitoring, and command features are centralized in the use-case manager. This module is responsible for controlling the information demanded by sensors, actuators, users and AI. Below is a representation of the proposed control architecture.

4 SYSTEM MODELING

Petri nets are tools that use mathematical models and graphics that apply to a system that, by its

characteristics, allows modeling of system behavior, as well as graphical visualization, synchronization, parallel data processing and observation of competing systems (Murata, 1989). These characteristics allow to follow the variations of the dynamic behavior of the modeled system, which in this case will be the test bench.

Petri nets have been used in various applications, for example, to model complex biological systems of yeast cell cycles based on multisite phosphorylation (Herajy; Liu; Heiner, 2018), modelling and analysis of traffic signal priority control systems (An et al., 2018) in accidents, in the cascade analysis for vapor cloud explosions of flammable fuels (Zhou; Reniers, 2017), interoperability test bench model for embedded train control system (Yuan et al., 2010), and, approach for the evaluation of the reliability of the final elements of the Instrumented Security System with time-dependent failure rates (Wu *et al.*, 2018).

5 METHOD

The research has a theoretical and quantitative descriptive methodological approach, since it aims to discover the existence of associations and correlations between variables (Mattar, Oliveira and Motta, 2014) and prospective in the timeline (Fontenelles *et al.*, 2009) when a method of experimentation is proposed by means of *in vitro* models. Modeling through the Petri net completes the *In vitro* model, allowing the simulation of the process in a computational model of a real system, conducting experiments with this model with the purpose of understanding and validating its behavior (Centeno, 1996).

On the other hand, the technical procedures, related to the method, are the application of the Petri net to model the dynamic behavior of the variables of the VADs in tests, obtaining the behavior of faults by deviations when compared to the standard curves of these variables (pressure, flow, vibration, temperature, viscosity, density, rotation and energy). Decision making is based on maintaining the longevity of the life of the device being tested, in which two agents can act: a) an AI module that is based on machine learning and b) a human assistant.

5.1 Data Collecting and Handling

The "context" information source (Wan, 2009) of the assisted device is connected to the sensors in the "Test Bench", from which it transfers this

information to a real-time cloud knowledge base. This knowledge base is handled by a standards analyzer for knowledge discovery using Big Data Analytics technologies.

In this paper "context" is any information that can be used to characterize the situation of an entity (object of interest), it is also known as sentient computing (Andrade, 2015). Thus, an entity can be a person, a place, or an object that is considered relevant to the interaction between a user and an application, including the user and the applications themselves (Schilit; Adams; Want, 1994).

5.2 Data Analysis

The Big Data Analytics' approaches to pattern discovery are based on: (i) Descriptive Analysis - Real-time understanding of events so that immediate decisions can be made. The descriptive analysis works with data history, crossing information with the objective of generating a clear and precise panorama of the relevant themes for the present moment, without necessarily relating it to past or future patterns (Marquesone, 2016). (ii) Diagnostic Analysis: Its objective is to understand the relation of cause and effect (Who, When, How, Where and Why) perceived over time and its possibilities. It works based on the collection of data related to a certain subject, crossing information in order to understand which factors influenced the current result (Marquesone, 2016). (iii) Predictive Analysis: Known for "predicting" the future, we use data mining: statistical and historical data to know future trends (Marquesone, 2016). (iv) Prescription Analysis: Very confused with the predictive analysis, the prescriptive analysis works with the same logic, but with different objectives. While predictive analysis identifies future trends, the prescriptive outlines the possible consequences of each action. It is a way of defining which choice will be most effective in a particular situation (Marquesone, 2016).

6 SYSTEM MODELLING

The modeling developed for the system uses a systematic and refinement approach. Using a combination of the work of Villani (2004) to perform the modeling of the supervisory control and monitoring system of the test bench (Figure 3). In step 1, fluid flow modeling is performed by the bench of tests to characterize the dynamics of the test bench (Villani *et al.*, 2004).

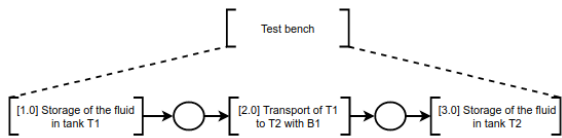

Figure 3: PFS model of the test bench.

In step 2 all desired functionalities are described for the control and monitoring system of the test bench (Villani et al., 2004). In step 3, the implementation strategies of the control system are described, so it is specified how the system should behave for each use case. In step 4, the modeling procedures begin by performing the modularization of the system components. In step 5, the component models for analysis are integrated. In step 6, the models are analyzed from the main properties of Petri nets.

6.1 Step 1: Modeling Material Flows

This step aims to define the boundaries of the test bench that will be controlled by a command and monitoring control system. This model is built on PFS (Product Flow Schema), which is based on the concept of successive refinement (Villani et al., 2004). For more information on PFS modeling and successive refinement, it is recommended to read Miyagi (1988).

The activities of [Storage of the fluid in tank T1] and [Storage of the fluid in tank T2] are detailed in Figure 4 so that no further refinement is required. For the activity [Transport of T1 to T2 with B1], one can drill down to another level.

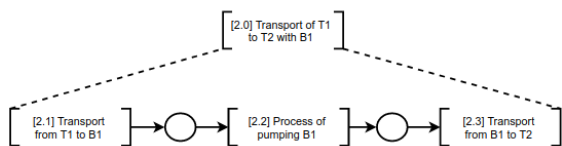

Figure 4: Activity Detail [Transport of T1 to T2 with B1].

From this model it is possible to highlight the dependencies and inputs and outputs of the operational process of the test bench.

6.2 Step 2: Definition of Use Cases

1. The system agents (user and AI) can parameterize the flow reference flowing through valve V1 and pump motor rotation reference B1.

Table 1: Assignment of features for each control device.

Devices	Activities
Sensors	-Publish value collected to the communication manager
Actuators	-Receive new reference from the communication manager
Communication Manager	-Receive value collected from the sensors -Receive new physical event manager reference; -Publish value collected from sensors to the physical event manager; -Publish new reference received by the physical event manager to the actuators;
Physical Event Manager	-Direct publication and receipt of the use case manager and communication manager;
Use Event Manager	-Direct publication and receipt of the mobile / desktop devices and use-case manager;
Mobile / desktop device	-Request data from the sensors stored in the database; -Apply new reference to actuators; -Measure new sensor value limits; -Receive alert for abnormal values;
Database	-Save data collected from sensors; -Save sensor limit value; -Store new actuators reference; -Consult stored values of the sensors;
Use case manager	-Receives value collected in the sensor of the physical event manager, validates the measured value to ensure that it is within the accepted limits of the standard curve of pump B1 and stores in the database; -Receives new reference value from the actuators of the event manager, stores it in the database and publishes it to the physical event manager; -Receives new threshold value from the sensors of the event manager and stores it in the database; -Receive request to query the sensor data in the database of the event manager and publish the data in the event manager;

2. System agents (user and AI) can parameterize a pressure value limit on sensors PT1, PT2 and PT3, vibration on sensor VT1, rotation on sensor ST1, electric current on sensors IT1 and IT2, temperature on sensor TT1 and the FT1 sensor.

3. System agents (user and AI) can monitor the pressure values in the PT1, PT2 and PT3 sensors, vibration in the VT1 sensor, rotation in the ST1 sensor, electric current in the IT1 and IT2 sensors, temperature in the TT1 sensor and flow in the FT1 sensor.
4. The supervisory system collects the pressure values on the sensors PT1, PT2 and PT3, vibration on the VT1 sensor, rotation on the sensor ST1, electric current on the sensors IT1 and IT2, temperature on the sensor TT1 and flow on the sensor FT1 and stores in the bank data.

6.3 Step 3: Specification of Control Strategies to Be Modeled

From the proposed control architecture, we identify mobile / desktop devices, use case manager, communication manager, database, test bench, physical event manager and event manager. Table 1 specifies the assignment of functionality for each device.

6.4 Step 4: Construction of Components

From the control strategies (step 3) and proposed control architecture, the modelling procedures are started. For each device specified in the strategies there will be a Petri net. In this way, integrating the devices according to their needs, one must build the Petri net models of the mobile / desktop device, use case manager, database, event manager, physical event manager and communication manager. The final goal of device integration can be seen in Figure 5.

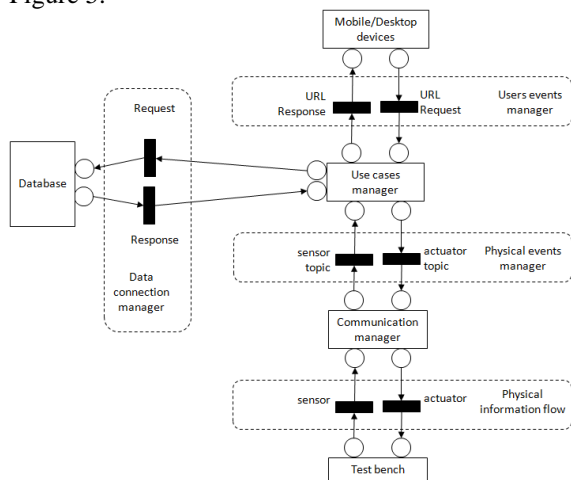

Figure 5: Interactions of the supervisory control.

6.5 Step 5: Integrated Component Modelling

In the integrated modeling, the component models are combined to perform the Petri nets verification from their properties for each of the system use cases: collection, validation and storage of the sensor data.

6.6 Step 6: Analysis of Models

The analysis of the models is performed for each of the use cases, so that the properties of the mark diagram are evaluated, it is verified if the modelled Petri net is limited, safe, alive and bootable.

7 RESULTS AND DISCUSSION

The research sought to analyse the automation of a test bench, using resources: modelling of dynamic behavior, through the Petri net; to provide intelligent behavior with the use of AI and machine learning, in face of the changes of the monitored variables; as well as the use of diagnostic and prognostic features in Big Data Analytics technology for data analysis and treatment.

From the analysis of the properties of the models and simulations performed in the validation of each of the specified use cases for the control system, it is identified that the proposed system meets the functional requirements according to the model properties checks. However, it requires simulation tests for adjustments in the predictive and diagnostic model, which still causes conflicts with the user's decision regarding the adjustments made by the AI model.

8 CONCLUSIONS

The purpose of this work is to explore the benefits of the introduction of intelligent control systems, applied to a test bench of ventricular assist devices (VAD), allowing to these “in test” devices the greatest possible longevity of use, at the same time in which the behavior variations are identified, observing the changes in the dependent variables, while controlling the independent ones, by means of the set-up change of these variables.

The final result obtained is: a knowledge database containing: a) failure data and respective behaviors over time, allowing intelligent control to

predict future consequences, from tests of new devices; b) a set of improvements that can be applied to the design of new devices, allowing more durable devices; c) refinement of a learning system as it continually evaluates the test results, compared to the designs of each device, e.g. device with such design characteristics as: structure, form of construction, materials used, among others, have tendencies of behavior, which can lead to a set of predictive actions; d) the subsidy and experience for the elaboration of a new challenge, of a robotic device (VAD) that can, depending on the construction project, use this knowledge base to provide longevity of use of its resources and limitations, consequently creating longevity of its host.

A robotic VAD could have adaptive and resilient behavior, being flexible without the need to be reprogrammed, since robots are designed to be able to perform various tasks based on simple programming (Niku, 2013).

With these elements, it can be concluded that the control system for control and monitoring of the test bench provides significant gains for the detailed study of the operation of VADs. With the collection of more flexible information and interfaces it is possible to carry out analysis and data collection that help in the continuous improvement of these devices.

ACKNOWLEDGEMENTS

The authors thanks FAPESP, CNPQ e CAPES for supporting this research.

REFERENCES

- An, Y. *et al.* (2018) ‘Hierarchical Colored Petri Nets for Modeling and Analysis of Transit Signal Priority Control Systems’, *Applied Sciences*, 8(1), p. 141. doi: 10.3390/app8010141.
- Andrade, L. A. de (2015) *Jogos Digitais, Cidade e (Trans)mídia: A Próxima Fase*. Curitiba: Editora Appris.
- Atoche, A. C. and Marrufó, O. P. (2011) “‘Nuevas Tendencias en Sistemas Mecatrónicos’”, *Ingeniería*, 15(2).
- Cassandras, C. G. and Lafourtune, S. (2008) *Introduction to Discrete Event Systems*. Boston: Springer US.
- Centeno, M. A. (1996) ‘An introduction to simulation modeling’, *Winter Simulation Conference*, pp. 15–22. doi: 10.1109/WSC.1996.873255.
- Christie, J. D. *et al.* (2012) ‘The registry of the international society for heart and lung transplantation: 29th adult lung and heart-lung transplant report - 2012’, *Journal of Heart and Lung Transplantation*. Elsevier Inc., 31(10), pp. 1073–1086. doi: 10.1016/j.healun.2012.08.004.
- Cowger, J. A. *et al.* (2018) ‘Quality of life and functional capacity outcomes in the MOMENTUM 3 trial at 6 months: A call for new metrics for left ventricular assist device patients’, *Journal of Heart and Lung Transplantation*. Elsevier Inc., 37(1), pp. 15–24. doi: 10.1016/j.healun.2017.10.019.
- Drakos, S. G. *et al.* (2010) ‘Risk Factors Predictive of Right Ventricular Failure After Left Ventricular Assist Device Implantation’, *American Journal of Cardiology*. Elsevier Inc., 105(7), pp. 1030–1035. doi: 10.1016/j.amjcard.2009.11.026.
- Evans, J. W. and Sinha, K. (2018) ‘Applications of fracture mechanics to quantitative accelerated life testing of plastic encapsulated microelectronics’, *Microelectronics Reliability*. Elsevier, 80(October 2017), pp. 317–327. doi: 10.1016/j.microrel.2017.10.022.
- Flyn, J. R. (2009) *O que é Inteligência? Além do efeito Flyn*. Porto Alegre: Editora Artmed.
- Fontenelles, M. J. *et al.* (2009) ‘Metodologia da pesquisa científica: diretrizes para a elaboração de um protocolo de pesquisa 1’.
- Goldstein, D. J. *et al.* (2018) ‘Impact of age, sex, therapeutic intent, race and severity of advanced heart failure on short-term principal outcomes in the MOMENTUM 3 trial’, *Journal of Heart and Lung Transplantation*. Elsevier Inc., 37(1), pp. 7–14. doi: 10.1016/j.healun.2017.11.001.
- Healy, A. H. *et al.* (2016) ‘Predictors of 30-day post-transplant mortality in patients bridged to transplantation with continuous-flow left ventricular assist devices - An analysis of the International Society for Heart and Lung Transplantation Transplant Registry’, *Journal of Heart and Lung Transplantation*. Elsevier, 35(1), pp. 34–39. doi: 10.1016/j.healun.2015.07.007.
- Herajy, M., Liu, F. and Heiner, M. (2018) ‘Efficient modelling of yeast cell cycles based on multisite phosphorylation using coloured hybrid Petri nets with marking-dependent arc weights’, *Nonlinear Analysis: Hybrid Systems*. Elsevier Ltd, 27, pp. 191–212. doi: 10.1016/j.nahs.2017.09.002.
- Ijaz, M. F. *et al.* (2017) ‘Novel Electrochemical Test Bench for Evaluating the Functional Fatigue Life of Biomedical Alloys’, *Jom*. Springer US, 69(8), pp. 1334–1339. doi: 10.1007/s11837-017-2375-x.
- Khalifa, J. (ed.) (1995) *A Natureza da Inteligência: uma visão interdisciplinar*. São Paulo: Fundação Editora Unesp.
- Kuhn, M. F. *et al.* (2018) ‘A Novel RFID-Based Strain Sensor for Wireless Structural Health Monitoring’, *Journal of Nondestructive Evaluation*. Springer US, 37(2), p. 22. doi: 10.1007/s10921-018-0475-3.
- Lopes, G., Bock, E. and Gómez, L. (2017) ‘Numerical Analyses for Low Reynolds Flow in a Ventricular Assist Device’, *Artificial Organs*, 41(6), pp. E30–E40.

- doi: 10.1111/aor.12776.
- Marquesone, R. (2016) *Big Data - Técnicas e tecnologias para extração de valor dos dados*. São Paulo: Editora Casa do Código. Available at: <http://forum.casadoCodigo.com.br/>.
- Mattar, F. N., Oliveira, B. . and Motta, S. L. S. (2014) *Pesquisa de Marketing: metodologia, planejamento, execução e análise*. 7th edn. Edited by Elsevier. Rio de Janeiro.
- Mozaffarian, D. *et al.* (2016) *Heart disease and stroke statistics-2016 update a report from the American Heart Association, Circulation*. doi: 10.1161/CIR.000000000000350.
- Mueller, N. *et al.* (2017) 'Design of a right ventricular mock circulation loop as a test bench for right ventricular assist devices', *Biomedical Engineering / Biomedizinische Technik*, 62(2). doi: <https://doi.org/10.1515/bmt-2016-0104>.
- Mühlhäuser, M. (2007) 'Smart Products: An Introduction', *Smart Products: An Introduction*, (AmI 2007 Workshops), pp. 158–164. doi: 10.1007/978-3-540-85379-4.
- Murala, J. and Si, M. (2017) 'Mechanical circulatory support for the failing functional single ventricle', *Translational Pediatrics*, 6(1), pp. 59–61. doi: 10.21037/tp.2016.10.09.
- Murata, T. (1989) *Petri Net: Properties, Analysis and Applications, Petri Net Theory*. Chicago: IEEE.
- Nichols, M. *et al.* (2015) *Australian Heart Disease Statistics 2015, Australian Heart Disease Statistics*. Available at: https://www.heartfoundation.org.au/images/uploads/publications/RES-115-Aust_heartdisease_statistics_2015_WEB.PDF.
- Niku, S. B. (2013) *Introdução à robótica: análise, controle, aplicações*. Rio de Janeiro: LTC.
- Olia, S. E. *et al.* (2017) 'A Reusable, Compliant, Small Volume Blood Reservoir for *In vitro* Hemolysis Testing', *Artificial Organs*, 41(2), pp. 175–178. doi: 10.1111/aor.12724
- Russell, S. and Norvig, P. (2013) *Inteligência Artificial*. São Paulo: Elsevier Ltd.
- Schilit, B. N., Adams, N. and Want, R. (1994) 'Context-aware computing applications', *Proceedings of the 1994 First Workshop on Mobile Computing Systems and Applications*, pp. 85–90. doi: 10.1109/MCSA.1994.512740.
- Sharma, R., Singh, P. and Singhal, A. (2017) 'Two different authentication protocol for RFID credit card security', *Journal of Engineering and Applied Sciences*, 12(22), pp. 6006–6012.
- Silva, C. W. de (2005) *Mechatronics An Integrated Approach*. New York: CRC press.
- Sonawala, N. M., Tank, B. and Patel, H. (2017) 'Implementation of MQTT protocol in Context with Industry 4.0', 4(4), pp. 260–67.
- Tozzi, P. *et al.* (2017) 'An original valveless artificial heart providing pulsatile flow tested in mock circulatory loops', *International Journal of Artificial Organs*, 40(12), pp. 683–689. doi: 10.5301/ijao.5000634.
- Valis, D., Vintr, Z. and Koucky, M. (2010) 'Accelerated test used as a tool for manufacturing correctness check', in Bris, R., Martorelli, S., and S., G. S. & (eds) *Reliability, Risk and Safety: Theory and Applications - Bris*. London: CRC press, pp. 807–811.
- Villani, E. *et al.* (2004) 'Object oriented approach for cane sugar production: Modelling and analysis', *Control Engineering Practice*, 12(10), pp. 1279–1289. doi: 10.1016/j.conengprac.2004.04.011.
- Wan, K. (2009) 'A Brief History of Context', *Journal of Computer Science*, 6(2), pp. 33–43.
- Weiser, M. (1991) 'The Computer for the 21st Century', *Scientific American*, pp. 94–104. doi: 10.1038/scientificamerican0991-94.
- World Health Organization (2016) 'world health statistics monitoring health for the sdg s'.
- Wu, S. *et al.* (2018) 'Reliability assessment for final elements of SISs with time dependent failures', *Journal of Loss Prevention in the Process Industries*. Elsevier, 51(October 2017), pp. 186–199. doi: 10.1016/j.jlp.2017.12.007.
- Yuan, L. *et al.* (2010) 'Modeling of an interoperability test bench for the on-board system of a train control system based on Colored Petri Nets', *WIT Transactions on the Built Environment*, 114, pp. 271–280. doi: 10.2495/CR100261.
- Zhang, H. and Jiang, M. (2017) 'An Integrated Approach for Implantable Medical Devices Fatigue Reliability Prediction', pp. 0–5.
- Zhou, J. and Reniers, G. (2017) 'Petri-net based cascading effect analysis of vapor cloud explosions', *Journal of Loss Prevention in the Process Industries*. Elsevier Ltd, 48(October 1989), pp. 118–125. doi: 10.1016/j.jlp.2017.04.017.