

An Alternative Method for Kinematic Modelling Applied to the Human Joint Position

Bibiana Hernández-Hernández^{1,2}, Cesar Ramos-Villa^{1,2}, Dulce Martínez-Peon^{1,2},
Eduardo Torres-Sarmiento^{1,2} and Ernesto Olguín-Díaz³

¹*Division of Studies and Postgraduate Research, Institute of Technology of Nuevo Leon, Mexico*

²*National Technological Institute of Mexico, Mexico*

³*Robotics and Advanced Manufacturing Group, Cinvestav, Coahuila, Mexico*

Keywords: Kinematic Modelling, GRyMA Methodology, Biomechanics.

Abstract: The kinematic description of a mechanical structure is an essential part of the motion analysis. In human-like structures, kinematics works as a biomechanical base for the analysis of the human motion in areas like rehabilitation and sports. While nowadays the standard is based on the Denavit-Hartenberg convention, which has been defined for industrial mechanical use, this approach may need virtual reference frames when having non orthogonal systems and complex geometries like human body. This work presents a kinematic analysis focused on lower limbs using an alternative to the Denavit-Hartenberg convention for reference frames assignment in kinematic modelling, called the GRyMA methodology. Finally, the paper also shows Matlab©-based simulation of a CAD model emulating the human lower limbs motion. The kinematic analysis could be used in the assessment of the joint position of individuals with some walk or sports disability, and therefore also in the correct treatment or posture improvement.

1 INTRODUCTION

Biomechanics is the science that involves the study of the mechanical features of living organisms, mainly focused on human anatomy, (Hall, 2012). There are two important concepts within this discipline: Kinematics, a part of mechanics field that studies the motion of objects regardless of the forces applied to them, including displacement, velocity and acceleration; and Kinetics, which studies the forces that produce the body motion and its changes, (Bergmann and Peterson, 2011).

Human motion analysis observes in detail the human motion in order to gather quantitative information about the mechanics of the body when executing different tasks. In this branch, the study of the human gait is very important because of its use in clinical management like planning and treating individuals with some walking or sports disability; or to estimate the joint positions of a healthy runner, (Lu and Chang, 2012). The kinematic field provides an accurate description of the human motion and it is fundamental to understanding its biomechanics, (Knudson, 2007).

In sports, posture analysis is fundamental and

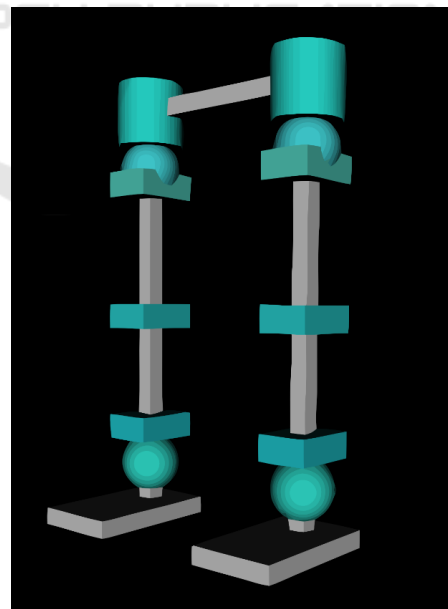

Figure 1: 12 DoF lower limbs model (6 for each leg).

must be obtained precisely. Some analysis techniques includes numerical methods like small series of kinematic patterns, (Bharatkumart et al., 1994), pre-

dictions of length patterns of in-vivo ligaments with global position vectors, (Lewis and Lew, 1978), models estimation for anatomical joints with minimum squared error, (Sommer and Miller, 1980). Scott, purpose a software to analyse musculoskeletal structures from input parameters provided by user where kinematics is solved using transformations (orthogonal translations and rotations) between axes having as a reference the HUMERUS and ULNA segments, (Delp and Loan, 1995). Hanavan takes advantage of computers as an useful tool when modelling human body and purposes a 15 geometric solid mathematical model for body modeling, based in antropometric dimensions, and describes body positions with Euler angles, (Hanavan JR, 1965); while Bogert and their colleagues designed a software system able of calculating forward and inverse kinematics of 44 degrees of freedom (DoF), (Bogert et al., 2013). Baldisserri and Castelli made a 3D kinematic model considering four bones (tibia, fibula, talus and calcaneus) to emulate passive motion; the analysis was made using Denavit-Hartenberg transformation matrices, (Baldisserri and Castelli, 2010).

In addition to the aforementioned techniques, there are alternative marker-based methods, (Rab et al., 2002) that can be subdivided in two categories: contact based techniques, including accelerometers and goniometers sensors, and non-contact based techniques using active LEDs (Light-emitting diodes) or passive markers (tags), (Prakash et al., 2015). Nonetheless, there is still much to do in technological improvement, mathematical modelling of musculoskeletal system and more techniques to quantify and reduce measurement errors, (Lu and Chang, 2012).

In Kinematics, the most common method to describe the link structure of an articulated body is the well known Denavit-Hartenberg method, (S.Kajita, 2014); although it is not always practical when analysing complex systems. Therefore the present work proposes an alternative method in the assignation of reference frames known as GRyMA methodology, (Báez and Olgún-Díaz, 2013).

This work is organized as follows. In Section 2, the alternative approach of the forward kinematics is explained, detailing the algorithms to allocate the reference frames as well as the structure of the homogeneous transformations. Section 3 presents a case of study representing the basic motion of human lower limbs by applying the alternative GRyMA methodology. In Section 4, simulation on a 3D CAD model is presented using the GRyMA procedure in order to show the simplicity and functionality of the proposed method. Finally, the conclusions are stated in Section 5.

2 METHODOLOGY DESCRIPTION

The most common method used to calculate kinematics within a kinematic chain consisting of articulated bodies is by using order 4 homogenous transformations as:

$$A = \begin{bmatrix} R & d \\ 0 & 1 \end{bmatrix} \in SE(3)$$

Each of these transformations represents a rotation (through the 3 DoF Rotation matrix $R \in SO(3)$) and a translation (through the 3 DoF displacement $d \in \mathbb{R}^3$). Then by assigning a reference frame (normally under the right hand rule) in each rigid body in the kinematic chain, it arises an homogenous transformation between these frames upon which any position and hence its time derivative values can be calculated.

These homogeneous transformations needs 6 linearly independent parameters to be described. In this sense the Denavit-Hartenberg convention imposes two restrictions on each two consecutive frames, which reduces the complexity of each homogeneous transformation to only four parameters. Even more, for articulated bodies in a kinematic chain, only one of these parameters is variable becoming the relative joint value, while the remanent 3 constant parameters describes the kinematic chain. This methodology has been proven to be very useful and simple even in complex systems. However it has been designed specifically for mechanical systems where the two constraints needed are always fulfilled.

These constraints are seldom fulfilled on complex systems like biomechanical ones, for which most of the time an additional virtual frame in each articulation has to be included to guarantee the validity of the methodology. In these cases, the number of parameters needed to describe a single articulation increases to 8 (with only one variable) which renders the homogeneous transformation more complicated than the original of 6 DoF without the DH convention.

An alternative approach for the assignation of these frames is the GRyMA method (After *Grupo de Robótica y Manufactura Avanzada*), where the origin of every reference frame Σ_i is placed at any user chosen point along the articulation axis, and always parallel to the inertial frame at the home position of the system. Then the homogeneous transformation of the child/parent frames ($A_i : \Sigma_{i-1} \rightarrow \Sigma_i$) can be expressed as, (Báez and Olgún-Díaz, 2013):

$$A_i = \begin{bmatrix} R(\lambda_{Ri}, q_i(t)) & d_i + \lambda_{Ti} q_i(t) \\ 0 & 1 \end{bmatrix} \quad (1)$$

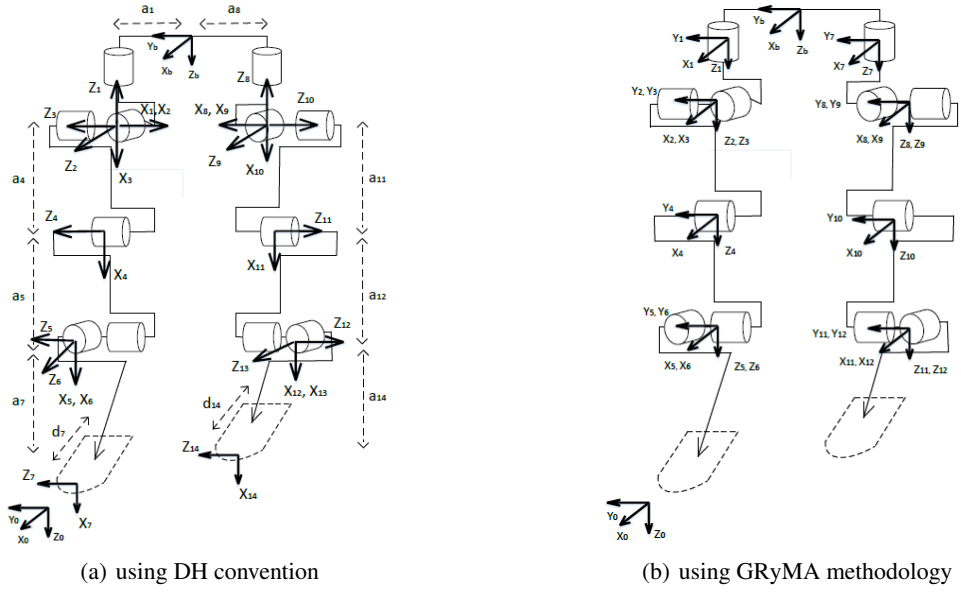

Figure 2: Reference frames, note that in figure b all the axes including global reference frame are oriented in the same direction.

where q_i is the variable generalized coordinate corresponding to the articulation; the 3D distance $d_i \in \mathbb{R}^3$ in coordinates of the parent frame $i-1$, is the constant position of the origin of the child's frame; the unit director vectors λ_{Ri} and λ_{Ti} (composed of 3 elements each), also in coordinates of parent frame, define whether the articulation is rotational or prismatic (respectively) and the rotation matrix is defined upon the axis/angle representation.

Then the mode and direction of the articulated joint is given by the kinematic director $\lambda_i(\theta_i) = (\lambda_{Ri}^T, \lambda_{Ti}^T)^T \in \mathbb{R}^6$, where λ_i can be codified with the scalar parameter θ_i according to the Table 1, using only 4 constant parameters and one variable for each articulation. The GRyMA methodology uses Algorithm 1 to place the reference frames.

Table 1: Kinematic director.

θ	0	1	2	3	4	5	6
	0	1	0	0	0	0	0
λ_{Ti}	0	0	1	0	0	0	0
	0	0	0	1	0	0	0
λ_{Ri}	0	0	0	0	1	0	0
	0	0	0	0	0	1	0
	0	0	0	0	0	0	1

Where:

θ Indicate which axis will have a movement

λ_{Ri} Indicate rotation movement

λ_{Ti} Indicate translation movement

Algorithm 1: GRyMA methodology for Frame Assignment, (Báez-Golubowski, 2015).

- 1: Identify the motion axes of the articulations in the system.
- 2: Assign the root (not always the inertial one) reference frame Σ_0 in a way that the position and orientation are strategically defined with the motion axes of the system. Allocating it along the first articulation is useful because it would simplify the parameters.
- 3: Assign each reference frame Σ_i of the i -link with the origin along the articulation axis and taking the same orientation as defined in the inertial frame. If possible the origin may be allocated to intersect the motion axis of the parent frame too, in order to make one of the three position parameters equal to zero and simplify the parametric definition.
- 4: Define the distance vector $d_i \in \mathbb{R}^3$ from the Σ_{i-1} frame to the Σ_i frame.
- 5: Codify the direction parameter θ according to Table 1.

3 EXPERIMENTAL WORK

In this section, GRyMA methodology is applied to the 3D study case model, which stands for 7 segments of the human lower limbs.

The assignment of the reference frame Σ_0 defines the orientation of the other frames at initial or home

position. The restriction is that all articulation axes have to be aligned to any axis of the frame Σ_b in order to simplify the analysis to 4 constant parameters and one joint variable, shown in Table 2 according to the Table 1, for the same case of study. Figure 2(b) shows the corresponding frame assignment.

Table 2: GRyMA kinematic parameters.

Joint	d_x	d_y	d_z	θ	Σ Parent
1	d_{x1}	d_{y1}	d_{z1}	6	Σ_b
2	d_{x2}	d_{y2}	d_{z2}	4	Σ_1
3	d_{x3}	d_{y3}	d_{z3}	5	Σ_2
4	d_{x4}	d_{y4}	d_{z4}	5	Σ_3
5	d_{x5}	d_{y5}	d_{z5}	5	Σ_4
6	d_{x6}	d_{y6}	d_{z6}	4	Σ_5
7	d_{x7}	d_{y7}	d_{z7}	6	Σ_b
8	d_{x8}	d_{y8}	d_{z8}	4	Σ_7
9	d_{x9}	d_{y9}	d_{z9}	5	Σ_8
10	d_{x10}	d_{y10}	d_{z10}	5	Σ_9
11	d_{x11}	d_{y11}	d_{z11}	5	Σ_{10}
12	d_{x12}	d_{y12}	d_{z12}	4	Σ_{11}

The homogeneous transformation matrixes that define the position and orientation of the links reference frames are obtained after equation (1). The homogeneous transformation matrix of the final effector frame respect the root frame, its obtained again after expression (2).

$$T = \prod_{i=1}^n A_{i-1}^i = \begin{bmatrix} R_e(q) & d_e(q) \\ 0 & 1 \end{bmatrix} \quad (2)$$

Given this, the value of position d_e and orientation R_e of the final effectors (also known as Forward Kinematics) is obtained as functions of the joint coordinates ($\theta_1 \dots \theta_{14}$).

4 RESULTS

To test the kinematics results obtained by the GRyMA methodology, a 3D CAD model for the 7-segment model was made using V-Realm Builder tool of Matlab © to simulate the motion in human lower limbs. The joint structure shown in Figure 1 has 12 actuated DoF (the 6 DoF of the root frame has been constraint to have no motion), the hip joint has 3 DOF which allows the abduction-adduction, flexion-extension and rotation of the upper leg segment; the knee joint has 1 DoF for the flexion-extension lower leg segment; and the ankle is provided with 2 DOF, including the frontal flexion-extension and rotation of the foot.

The block diagram made in Simulink © to simulate the positions of the links can be appreciated in Figure 3.

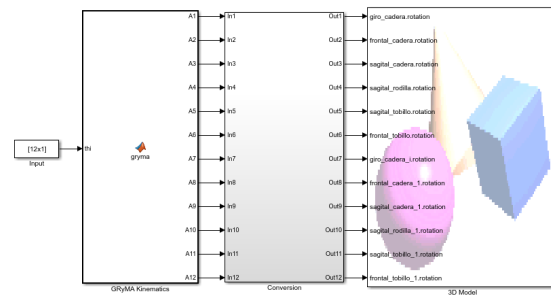

Figure 3: Simulation block diagram.

Anthropomorphic measures were taken into account to set the length of the links of the 3D CAD model as well as the tridimensional translation $d_i \in \mathbb{R}^3$ for the reference frames of the system. Human motion in lower limbs like rotation, extension-flexion, adduction-abduction and inversion-eversion were simulated. The results of the implementation of the GRyMA methodology are presented in Figure 4, which displays an approximation of the desired behavior of the system in the virtual world when performing different postures.

5 CONCLUSIONS

The Denavit-Hartenberg convention is the most common mathematical methodology in the assignment of frames to produce the kinematic study of articulated rigid multi-bodies systems but when it comes to more complex systems, auxiliar reference frames are needed, which can generate confusion when defining the centers of mass of the links, besides it makes the kinematic analysis harder by elevating the parameters by 4 each time an auxiliar frame is used.

One of the advantages of the GRyMA methodology is that the allocation of the children frames can be done (by definition of the GRyMA methodology) in such a way that also intersects the motion axis of the parent frame, this allows to make one of the three position parameters equal to zero and simplify the parametric definition.

Having a simplified homogeneous transformation becomes handy for the solution of the inverse kinematics, as an alternative to existing solutions.

ACKNOWLEDGEMENTS

We would like to thank CONACYT for the scholarships granting with numbers 612807, 605806 and 607608, which supported the studies of the students during their master.

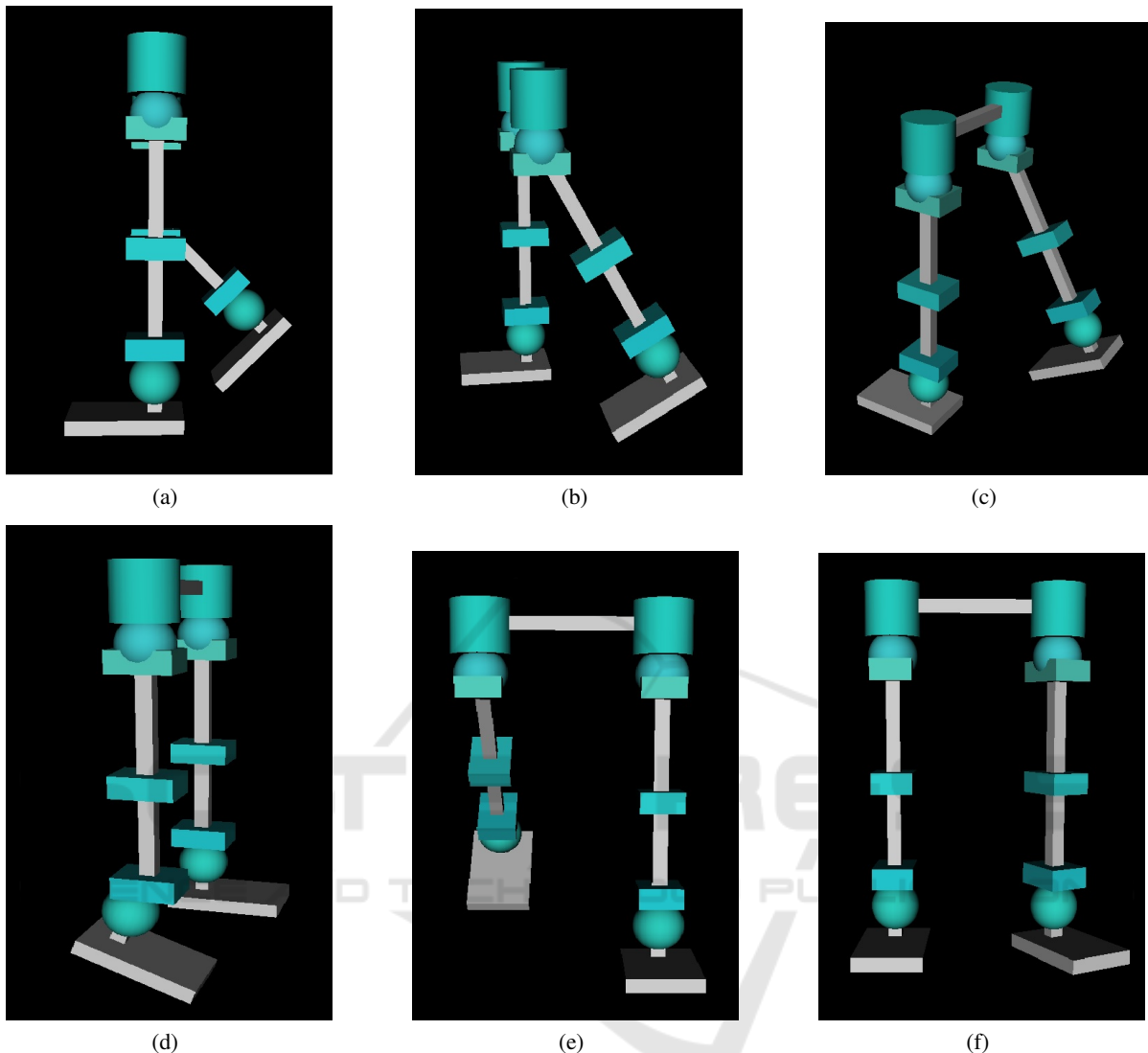

Figure 4: Representation of different movements in virtual model by applying the GRyMA methodology to the kinematic modelling: a), d) Sagittal displacement of the knee and the ankle respectively; b), e) Sagittal displacement of the hip; c) Frontal displacement of the hip; f) Horizontal displacement of the hip and Frontal displacement of the ankle.

REFERENCES

- Báez, G. and Olguín-Díaz, E. (2013). Control cinemático en el espacio operacional de un robot bípedo en fase de doble soporte. In *Congreso Internacional de Control Automático*, pages 502–507. AMCA and CICESE.
- Báez-Golubowski, G. I. (2015). Síntesis del ciclo completo de la marcha bípeda de un robot humanoide. Master's thesis, Centro de Investigación y de Estudios Avanzados del Instituto Politécnico Nacional CINVESTAV.
- Baldisserrri, B. and Castelli, V. P. (2010). A new spatial kinematic model of the lower leg complex: A preliminary study. In Pisla, D., Ceccarelli, M., Husty, M., and Corves, B., editors, *New Trends in Mechanism Science*, pages 295–302. Springer, New York.
- Bergmann, T. and Peterson, D. (2011). *Chiropractic Technique*. MOSBY.
- Bharatkumart, A. G., Daigle, K. E., Pandy, M. G., Cait, Q., and Aggarwalt, J. K. (1994). Lower limb kinematics of human walking with the medial axis transformation. *IEEE Workshop on Motion of Non-rigid and Articulated Objects*, pages 70–76.
- Bogert, A. J. V. D., Geijtenbeek, T., Even-Zohar, O., Steenbrink, F., and Hardin, E. C. (2013). A real-time system for biomechanical analysis of human movement and muscle function. *Medical & Biological Engineering & Computing*, pages 1069–1077.
- Delp, S. L. and Loan, J. P. (1995). A graphics-based soft-

- ware system to develop and analyze models of musculoskeletal structures. *Computers in Biology and Medicine*, 25:21–34.
- Hall, S. J. (2012). *Basic Biomechanics*. McGraw-Hill, New York, NY.
- Hanavan JR, E. (1965). A personalized mathematical model of the human body. *Journal of Spacecraft and Rockets*, 3:446–448.
- Knudson, D. (2007). *Fundamentals of Biomechanics*. Springer, New York, NY.
- Lewis, J. L. and Lew, W. D. (1978). A method for locating an optimal fixed axis of rotation for the human knee joint. *ASME Journal of Biomechanical engineering*, pages 187–193.
- Lu, T.-W. and Chang, C.-F. (2012). Biomechanics of human movement and its clinical applications. *Kaohsiung Journal of Medical Sciences*, 28:S13–S25.
- Prakash, C., Gupta, K., Mittal, A., Kummar, R., and LAXmi, V. (2015). Passive marker based optical system for gait kinematics for lower extremity. *Procedia Computer Science*, 45:176–185.
- Rab, G., Petuskey, K., and Bagley, A. (2002). A method for determination of upper extremity kinematics. *Gait and Posture*, 15:113–119.
- S.Kajita (2014). *Introduction to Humanoid Robotics*. Springer-Verlag, Berlin Heidelberg.
- Sommer, H. J. and Miller, N. R. (1980). A technique for kinematic modeling of anatomical joints. *ASME Journal of Biomechanical engineering*, pages 311–317.

