

Application Study of Hydraulic Turbochargers in Landfill Leachate Treatment Systems

Tong Liu¹, Yunguang Ji¹, Hongtao Li¹, Shu-qi Xue^{1*}, Mike Oklejas² and Shouzhi Yang³

¹ College of Mechanical Engineering, Hebei University of Science and Technology, Shijiazhuang 050018, China

²Oklejas Turbo Solutions LLC, Ann Arbor, MI 48103, USA

³Shijiazhuang Haikuojienergy Technology Co., Ltd, Shijiazhuang 050018, China

*Corresponding author e-mail: xueshuqi@hebest.edu.cn

Keywords: Landfill Leachate Treatment, Pressure Energy Recovery, Hydraulic Turbocharger, Energy Consumption, Seal.

Abstract: Based on the two-thousand-ton per day landfill leachate treatment process, a new system with energy recovery device was designed by using a hydraulic turbocharger to replace the circulation pump of the existing system. Energy consumption and equipment failure rate was decreased and system stability was improved by using hydraulic turbocharger. This study can provide a good reference for design and integration of energy recovery systems in landfill leachate treatment process.

1 INTRODUCTION

Landfill leachate is one kind of complex organic liquid produced in the process of landfill garbage storage, and it will cause serious environmental pollution if it is not treated before discharge. With the change of filling ages, the BOD/COD₅ value and pH value of landfill leachate will increase and it is difficult to use biochemical method merely to meet the emission standards for the treated liquid. Reverse osmosis (RO) process is little influenced by the factors such as composition and temperature, and it ensures the stability of water quality and has great advantages in the treatment of landfill leachate with high concentration of salt (ZHANG Lina, 2016), so biochemical treatment and/then RO process has become the mainstream technology in landfill leachate treatment. However, in the usually used disc tube reverse osmosis (DTRO) treatment system, the pressure energy is wasted because that the high pressure brine is discharged through pressure release valve directly after the first stage RO process. In this paper, a hydraulic turbocharger is used to replace the electric circulating pump in existing DTRO system to recycle the brine pressure energy, which may provide a reference for design and configuration of energy recovery systems in landfill leachate treatment process.

1.1 Existing Landfill Leachate DTRO Treatment Process

As shown in Figure 1, in the current landfill leachate treatment process, after pre-treatment, landfill leachate is pumped through the first stage DTRO membrane and the left brine will be pressure-reduced by a pressure release valve and returned the concentrated tank; the filtered liquid by the first stage DTRO membrane is then pumped through the second stage DTRO membrane and the left brine in this stage will be returned back and then pumped through the first stage membrane again. Liquid filtered by two-stage DTRO membrane may enter the stripping tower and tank, and can be discharged if its quality meets the emission standard requirements. This process has been applied in a waste landfill of China and the measured liquid quality data of the inlet and outlet of the system are shown in Table 1. The operation data show that the recovery rate of the first and second stage DTRO membrane is 77% and 90% respectively and the overall recovery rate of the system is 75% (ZUO Junfang, et al., 2011).

Landfill leachate treatment process has high fresh water recovery rate and low flowrate and high pressure with the circulation brine, but the pressure energy is not recycled and reused, and it requires high sealing performance for circulating pumps.

Table 1: Water quality parameters of landfill leachate treatment systems.

	COD (mg.L-1)	BOD5 (mg.L-1)	SS (mg.L-1)	NH3-N (mg.L-1)	TN (mg.L-1)	pH value	conductivity
Inlet	≤20000	≤6000	≤1000	≤2000	≤2500	6~9	≤20000
Outlet	≤100	≤30	≤30	≤25	≤40	6~9	-

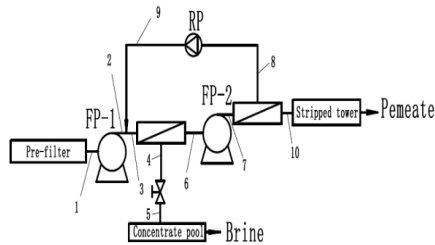

Figure 1: The existing landfill leachate treatment process (numbers refer to positions in Table 3).

1.2 Circulating Pump Used in the Existing System

In the existing process, the circulating pump shown in Figure 2 is used to pressurize the second stage brine to return to the first stage DTRO membrane and its inlet port pressure is 35bar, outlet pressure is 65bar, head is 300m. The high pressure of the inlet put strict requirements for the mechanical seal of the pump shaft connecting with the motor. High pressure mechanical seal is expensive, and the maintenance cost is high in the operation due to its low mean time between failures (MTBF).

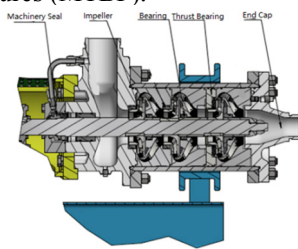

Figure 2: Internal structure of the circulation pump.

2 STRUCTURE OF HYDRAULIC TURBOCHARGER AND ITS APPLICATION IN DTRO PROCESS

2.1 Structure of Hydraulic Turbocharger

As shown in Figure 3, structure of hydraulic

turbocharger is similar to that of automotive engine turbocharger, where turbine section and pump section are connected by a central shaft. It can be used for pressure recovery and is widely applied in RO desalination system. Compared with the existing booster hydraulic turbine, hydraulic turbocharger has the advantages of simpler structure, higher efficiency, less leakage, and then higher reliability and longer operation time. The flow-through parts of the turbocharger are calculated by one dimension method firstly, and then key parameters are optimized by CFD numerical simulation, finally design efficiency is verified by experiments and testing (JI Yunguang et al., 2017). The central bearing in pump section bearing provides radial support, and the thrust bearing on the turbine section is used to balance the axial force between the turbine section and the pump section pressure difference which points to the turbine section. The bearing is self-lubricated so as has more compact and simple structure. Figure 4 is the hydraulic turbocharger prototype.

In the landfill leachate treatment system, in order to adapt to the corrosiveness of the high salinity medium, stainless steel SS2205 is used for the impellers and case of the turbocharger, and polyether ether ketone (PEEK) material is used for the thrust bearing.

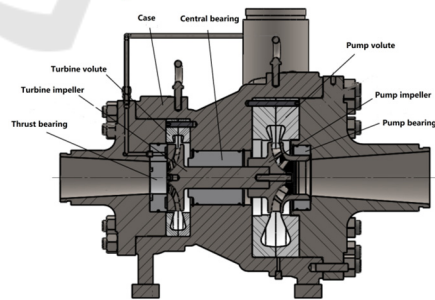

Figure 3: Internal structure of the hydraulic turbocharger.

2.2 Design Parameters and Energy Recovery Efficiency of Turbocharger

Table 2 is the design parameters of the hydraulic turbocharger for a two thousand ton landfill leachate

treatment system.

Table 2: Parameters of the turbocharger used in a 2000-ton/day landfill leachate treatment system.

Parameters	Values
Turbine Section Flowrate, Q_T	11.3 m ³ /h
Inlet pressure of turbine section, $P_{T,in}$	6 MPa
Outlet pressure of turbine section, $P_{T,out}$	0.5 MPa
Pump section flowrate, Q_p	6.75 m ³ /h
Inlet pressure of pump section, $P_{p,in}$	3.5 MPa
Outlet pressure of pump section, $P_{p,out}$	6.5 MPa
Overall-energy-recovery-efficiency, η	32.6%



Figure 4: The prototype of the hydraulic turbocharger.

The energy recovery efficiency of the hydraulic turbocharger can be calculated by the following equation:

$$\eta = \frac{Q_p(P_{p,in} - P_{p,out})}{Q_T(P_{T,in} - P_{T,out})} \quad (1)$$

2.3 Energy Recovery Process of Hydraulic Turbocharger

As shown in Figure 5, in the new process the circulating pump is replaced by hydraulic turbocharger cycle, and the discharge pipeline is connected to the turbocharger. The pressure energy of the first stage brine then can be recycled and pressure of second state can be boosted by the hydraulic turbocharger.

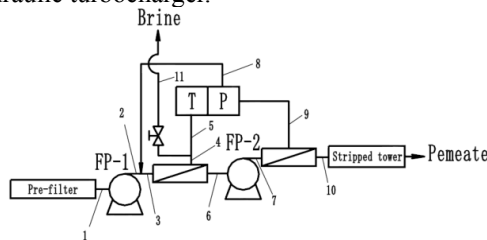

Figure 5 : Landfill leachate treatment process with a turbocharger.

Different from the RO desalination system, the flowrate of the first state is larger than that of the second stage in landfill leachate treatment process, and the available flowrate in the turbine section is greater than that needed for the pump section. Therefore, only a part of pressure energy in first stage brine is used to provide pressure for the second state circulating, then a pressure relief valve is designed to adjust the flowrate of turbine section. Compared with the existing system, the new system does not require a motor to provide mechanical energy, where the energy exchange between the first stage and second stage brine can be performed by the hydraulic turbocharger.

3 COMPARISON OF ENERGY CONSUMPTION

Hydraulic turbocharger energy recovery system is widely used in RO seawater and brackish water desalination,, petrochemical and other industries(Alisha Cooley, 2016). In this study, application of hydraulic turbocharger energy recycling device in landfill leachate DTRO treatment system is firstly proposed in China.

Table 3 lists flowrate and pressure on each position in the process of 2000-ton/day landfill leachate DTRO treatment system. The energy consumption the whole process is that of the pumps for providing pressure:

$$W = QTHg \quad (2)$$

where W is energy consumption of high pressure pump per hour (kWh), Q is flowrate (m³/h), T is time (H), H is pump lift (m), g is gravity constant.

Effective work W_1 of high pressure water pump FP is

$$W_1 = Q_1TH_1g\rho = 147.17kW \quad (3)$$

Effective work W_2 of boosting pump FP-2 is:

$$W_2 = Q_2TH_2g\rho = 75.49kW \quad (4)$$

Effective work W_3 of circulating pump RP is

$$W_3 = Q_3TH_3g\rho = 5.68kW \quad (5)$$

Total energy consumption per hour of the existing system is

$$W_{new} = W_1/\eta_1 + W_2/\eta_2 + W_3/\eta_3 = 292.5kW \quad (6)$$

where η_1 is the efficiency of the high pressure pump FP; η_2 is the efficiency of boosting pump of FP2, η_3 is the efficiency of the circulation pump FP3.

Table 4 shows the flowrate and pressure of the landfill leachate DTRO treatment system with a hydraulic turbocharger.

Table 3: Flowrate and pressure of existing landfill leachate treatment process.

Position	1	2	3	4	5	6	7	8	9	10
Flowrate/m ³	83.3	83.3	90.3	20.77	20.77	69.5	69.5	6.95	6.95	62.6
Pressure/MPa	0.1	65	65	60	0.5	0.1	40	35	65	0.5

Table 4: Flowrate and pressure of landfill leachate treatment process with hydraulic turbocharger.

Position	1	2	3	4	5	6	7	8	9	10	11
Flowrate/m ³	83.3	83.3	90.3	20.77	11.35	69.5	69.5	6.95	6.95	62.6	20.77
Pressure/M	0.1	65	65	60	60	0.1	40	35	65	0.5	0.5

Energy consumed by the new system is

$$W_{\text{new}} = W_1 / \eta_1 + W_2 / \eta_2 = 278.32 \text{ kW} \quad (7)$$

Electricity power saved every hour

$$W - W_{\text{new}} = 14.2 \text{ kW} \quad (8)$$

It is seen from the calculated results that hydraulic turbocharger used in the new process reduces the energy consumption by 14.2 kW or 5% compared with the existing landfill leachate DTRO treatment system.

4 CONCLUSIONS

A new system with energy recovery device is presented by using a hydraulic turbocharger to replace the circulation pump of the existing landfill leachate system. Calculation shows that the new system has lower energy consumption and failure rate, and higher operation stability due to no mechanical dynamic seals in the turbocharger. This study can provide a good reference for integration of hydraulic turbocharger energy recovery systems in landfill leachate DTRO treatment system.

However, the pressure energy is not recycled completely by the hydraulic turbocharger because the flowrate of the second stage brine is relative low in the two-stage landfill leachate treatment system, in this case a electricity generator may be integrated in the turbocharger as shown in Figure 6 (Tamer A. EI-Sayed et al., 2016), where the extra energy can be recycled and transformed to electricity power, which will be presented in the future research.

ACKNOWLEDGMENTS

This work was financially supported by key project of science and technology research of Hebei higher

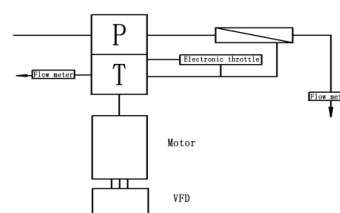

Figure 6: Hydraulic turbocharger with generator.

education institutions (ZD2015090); science and technology project of Hebei province, China (17394505D); 100 Talents Program of Hebei province, China (E2016100006); and introduction of foreign intelligence project of the year 2017 of Hebei province, China.

REFERENCES

- ZHANG Lina, 2016. *Process design of two-stage DTRO system for landfill leachate treatment*. China Water, 32 (16): 59-62 (in Chinese)..
- ZUO Junfang, et al., 2011. *Application of DTRO technology in the treatment of landfill leachate*. Membrane Science and Technology, 2011,31 (02): 110-115 (in Chinese).
- Ji Yunguang, et al., 2017. *Application study of fluid pressure energy recycling of decarbonization process by CAH6O3 in ammonia synthesis systems by hydraulic turbochargers*. Modern Chemical Industry, 37 (11): 158-161 +163 (in Chinese).
- Alisha Cooley, 2016. *Turbocharged cost savings in RO systems*. World Pumps, 6:36-41.
- Tamer A. EI-Sayed et al., 2016. *Performance of hydraulic turbocharger interated with energy management in SWRO desalination plants*. Desalination, 379: 85-92