

The Simple Open Free Running Test for the Evaluation of Turning Ship Ability

Aries Sulisetyono

Department of Naval Architecture, Institut Teknologi Sepuluh Nopember, Surabaya, Indonesia

Keywords: Ship Manoeuvring, Open Free Running Test, Image Processing.

Abstract: The ship manoeuvring test using an approach of the free running model on the open water pool is described. In this test, the most important part is to retrieve a trajectory data of the model ship while it does manoeuvre. It is necessary to have an accurate technique of the data retrieval during the test. A technique of image processing is proposed in this paper with the aim to analyse the ship manoeuvring path. In this method, the manoeuvring test of the model is recorded with the camera, and the movie result is then analysed with the movie maker software to get the trajectory points for a second step. The 6500 DWT tanker with a 1:85 scale model is tested on the turning test with the two different type of rudder namely the conventional and the single flap. The test results are obtained in terms of parameters including advances, transverse, tactical diameter and turning radius. The comparison results show the ship with single flap give better the manoeuvring performance with reducing turning diameter about 13.04% and 14.5% for the turning of Portside and Starboard respectively.

1 INTRODUCTION

The manoeuvrability of a ship is fulfilled to avoid the accidents of ship collision in open or restricted water areas. The IMO (International Maritime Organization) released the Standards for ship manoeuvrability for all ships that are operated in the sea. In the early step design of the ship, the ship manoeuvrability is predicted by using the approach of the experimental and numerical method. The free running model test is developed for testing of the ship manoeuvring. This experimental technique is more efficient and practical since it considers to follow the requirements of ITTC (25rd ITTC Manoeuvring Commission Report 2008). The model test is equipped with its own propeller and rudder on the scale in which the model is controlled by the operator through the wireless communication system.

The ship manoeuvrability basically depends on controllability the rudder performance and the ship speed. The rudder is designed to get a maximum value of side force to be able to change any directions of the ship's hull. In this paper, the single flap rudder is developed to improve the performance of ship manoeuvrability with increasing the side

force (Watson and Tupper, 2001); Lewis and Edwards, 1989). The foil of NACA 0018 series is selected refer to (Sulisetyono, 2014; Sulisetyono and Nasirudin, 2010, 2014) with about 30% addition flap of the rudder area. The turning manoeuvrability is considered with four parameters as the results of test such as advance, transverse, tactical diameter, and turning diameter. The image processing technique is proposed to analyse the turning path of the model ship while it tested at the certain speed for the two design cases of the rudders.

2 METHODOLOGY

The ship model is a 6500 DWT tanker with the main dimensions such as Length of water line (Lwl) 120 m, Breadth (B) 22.1 m, Draft (T) 7.12 m, Longitudinal centre of buoyancy (LCB) 58.7 cm (from FP), and Coefficient block (Cb) 0.773. The model with the scale of 1:85 is shown in Figure 1.

The turning test is conducted on the pool which has enough width to avoid the blockage effect, is the public swimming pool with the dimension of 12 m length, 6 m breadth, and 1.5 m depth. The ship models are equipped with including an AC motor, a

propeller shaft, and a propeller. The propeller is a single screw with 4 blades, diameter of 5 cm, and material of brass, which is installed in the stern model, as shown in Figure 2.

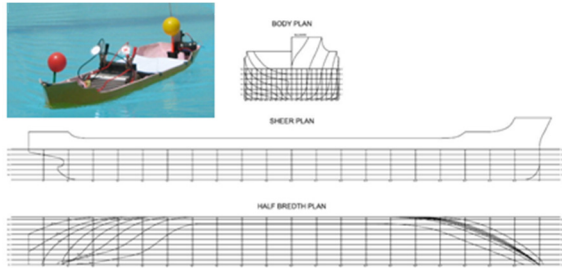

Figure 1: Lines plan and ship model of tanker 6500 DWT.



Figure 2: Propeller and rudder on the stern of model.

In order to make the ship model manoeuvre, the model's hull must be equipped with the rudder system. The servo motor with the power required 5 volts is needed to rotate the rudder, and it is removed in order to control the directions of the ship model. The remote-control system consists of 2 ways such as the command is sent according to the desire of operator by the moving stick, and the command is received in the form of signals which is sent by the remote control.

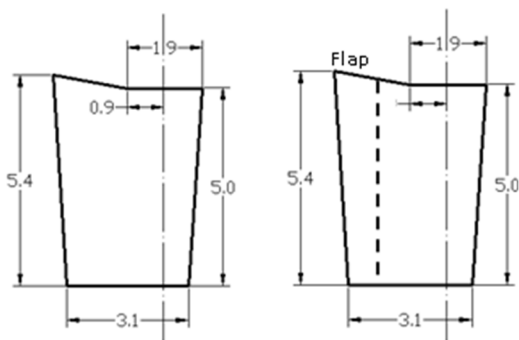

Figure 3: Rudder dimensions of conventional (left) and single flap (right).

The turning test is conducted to evaluate the performance of the two rudder types, namely the conventional rudder of type A, and the single flap

rudder of type B. The both section of rudders are asymmetrical foil of NACA 0018 series, and the wetted area of rudders are 17.6 cm^2 , as shown in Figure 3.

2.1 Testing Procedure

The procedures of the turning test are described as follow: First, to set up the position of the camera to record all trajectories of the ship model where it is installed on over the pool with the height of 4.8 m above the water surface, see Figure 4. The camera is connected to the computer to save or record the ship model manoeuvring.

Second, to obtain the point signs as the reference to figure the turning path. The 4 plastic balls that are given light to be seen clearly when the lights are turned off. The plastic ball is arranged into a square shape with the distance between ball are about 250 cm and 300 cm, see Figure 4. Later the pseudo square formed by these four plastic balls is used as a reference to calibrate the movement of the ship's model.

Third, to turn of all the lights around the pool, so that the colour recorded by the camera is the colour of the model of the ship and the lights of the ball. The ship model is executed and recorded.

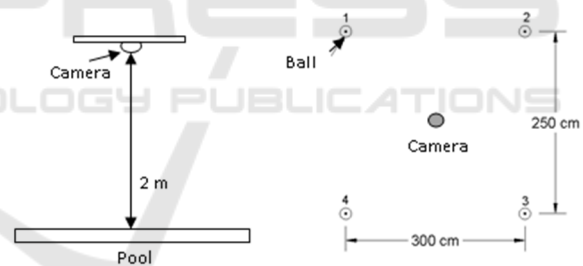

Figure 4: Position of the camera and the light ball in the pool.

2.2 Image Processing

The video of the ship manoeuvring tests is analysed with the following steps: first, the video recorded is imported into the application of movie maker. The movie is captured into several snapshots of ship movement per each second of time. Each picture shows the position of the ship model at every second on the turning track, see Figure 5. The second, each picture is identified as a point location of the ship model, and all points are then connected to become the line of the ship turning, see Figure 6. This ship turning line is further analyzed to look for the performance of ship manoeuvring.

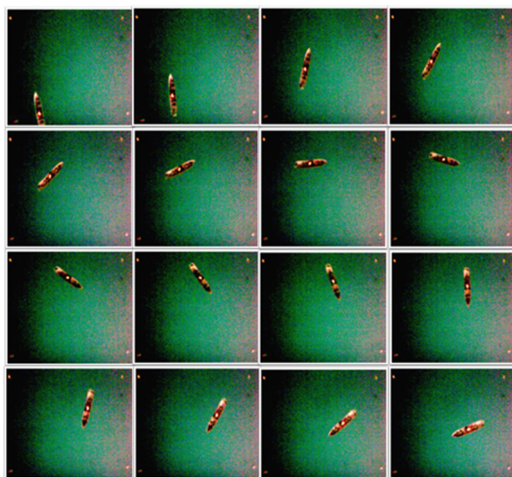

Figure 5: The position of the ship model for each time, from 1st second to 16th second.

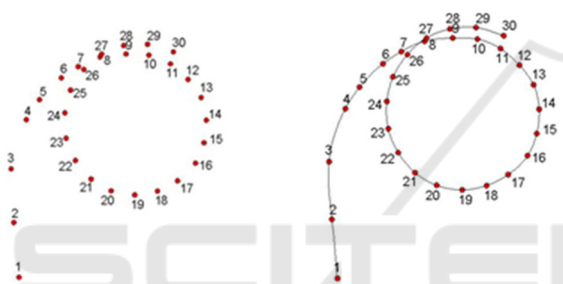

Figure 6: The point connected of the turning test, from 1st second to 30th second.

3 RESULTS AND DISCUSSION

The testing of free running models is to determine the manoeuvrability of the ship model in the turning circle test. The rudder angle used is based on the IMO standard which is a 35° towards the starboard and portside of the ship. Two types of the rudder which are the conventional and the single flap, are evaluated their contribution in the turning manoeuvre. Since the tests are carried out at night time, the lights have to be installed on the model ship as well as on the ball referenced in order to make it easier for the visual analysis. The test is conducted when the wind blow is very quiet since the wind factor contributes to the accuracy of the test results.

The results of the free running model test are expressed in plotting curve on the coordinate system of xy-axis. The sway motion of ship is a transverse motion obtained as the y-axis, and the surge motion is a longitudinal motion toward the length of the ship as the x-axis. For example, the results of turning test for the model ship with the rudder-type A is plotted,

as shown in Figure 7. The parameters of ship turning performance which are advanced, transfer, tactical diameter, and turning diameter are measured based on the curve turning circle.

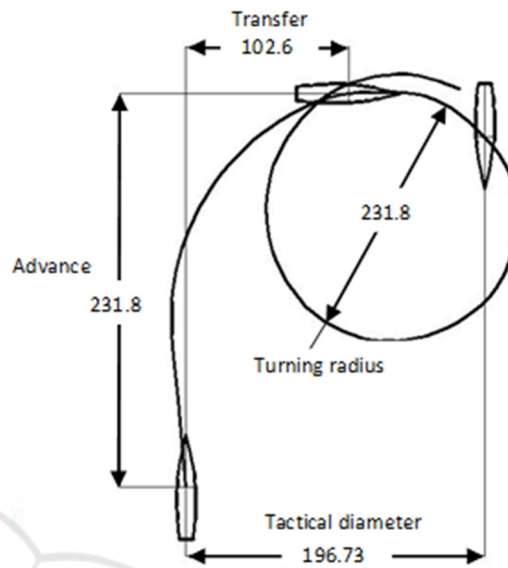

Figure 7: Results of the turning test for the ship model with the rudder type A (starboard).

Table 1 and 2 describe the results of the turning test of the model with the rudder-type A (the conventional rudder) and the rudder-type B (single flap rudder). Based on both tables, the type B of rudder produces smaller turning diameter while it is compared to the type A of the rudder which is decreases about 13.04% of Portside and 14.5% of Starboard.

Table 1: The results of the turning test of the model with the rudder-type A.

| Item of performance | Rudder angle | |
|------------------------|--------------|---------------|
| | 35° Portside | 35° Starboard |
| Advance (cm) | 244.99 | 231.81 |
| Transverse (cm) | 101.47 | 102.61 |
| Tactical Diameter (cm) | 202.94 | 196.73 |
| Turning Diameter (cm) | 138.92 | 149.25 |

The comparative performance of rudder type A and B is expressed in terms of the turning circle curve of the full-scale ship, as shown in Figure 8. This curve results also explain that the modification

of the conventional rudder with adding the flap on the rudder could provide an additional lift of the rudder so that the flap makes an effect in improving the performance of the ship manoeuvring at the sea.

Table 2: The results of the turning test of the model with the rudder-type B.

| Item of performance | Rudder angle | |
|------------------------|---------------------------|----------------------------|
| | 35° Portside and 10° flap | 35° Starboard and 10° flap |
| Advance (cm) | 213.05 | 198.21 |
| Transverse (cm) | 88.24 | 87.73 |
| Tactical Diameter (cm) | 176.48 | 168.22 |
| Turning Diameter (cm) | 120.81 | 127.62 |

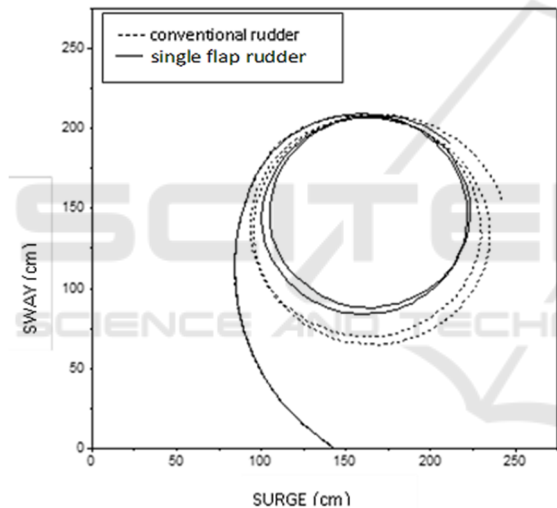

Figure 8: Comparison result of turning test for the model with rudder-type A and B (starboard).

4 CONCLUSIONS

The procedures of the open free running model test are proposed which is simply an alternative of the ship manoeuvring test in the open water pool. The two types of rudder such as the conventional rudder (type A) and the single flap rudder (type B) which are both have the same wetted surface area, are evaluated in giving influence to the performance of the turning manoeuvring. The test results show type B of the rudder (single flap) produces smaller turning diameters compared to type A of the rudder. The flap of the rudder can increase the manoeuvre

performance of the 6500 DWT tanker ship model is about 13.04% and 14.5% for Portside and Starboard turning, respectively.

ACKNOWLEDGEMENTS

The author wishes to thank Rizky Hariseputera as the student for helping in the experimental setup.

REFERENCES

A. Sulisetyono, 2014. The evaluation of a rigid sail of ship using wind tunnel test, *Applied Mechanics and Materials*, 493, pp 287-293.

A. Sulisetyono, 2014. Development of a Fish Tail Rudder to Improve a Ship's Maneuverability in Seaway, *IPTEK, Journal of Proceeding Series*, 1.

A. Sulisetyono and A. Nasirudin, 2010. Wind Sail Analysis Using Computational Fluid Dynamics Simulation, *The 7th International Conference on Marine Technology (MARTEC)*, Dhaka Bangladesh.

A. Sulisetyono and A. Nasirudin, 2014. Experimental of Untwisted Sail of Ship in Wind Tunnel Test, *The 9th International Conference in Marine Technology (MARTEC)*, Surabaya Indonesia.

K. J. Watson, and E. C. Tupper, 2001. *Basic Ship Theory – Volume 2 Ship Dynamics and Design*, Butterworth-Heinemann, Oxford.

Lewis, and Edwards, 1989. *Motions in Waves and Controllability, Principles of Naval Architecture Second Revision - Volume III*, (The Society of Naval Architecture and Marine Engineers (SNAME), Jersey City.

Testing and Extrapolation Methods Manoeuvrability Free Running Model Tests, 2008. *ITTC, Manoeuvring Committee of 25th ITTC*.