

Computational Fluid Dynamic Simulation of Clearance Effect and Velocity in Liquid Mixing System

Bayu Triwibowo¹, Astrilia Damayanti¹, Anwaruddin Hisyam², Dessy Ratna Puspita¹, Dwiana Asmara Putri¹

¹*Department of Chemical Engineering, Universitas Negeri Semarang, Semarang, Indonesia
Kampus UNNES Sekaran Gunungpati, Semarang 50229, Indonesia*

²*Faculty of Chemical and Natural Resources Engineering, Universiti Malaysia Pahang, Lebuhraya Tun Razak, 26300, Kuantan, Pahang Darul Makmur, Malaysia*

Keywords: Stirred Tank, CFD, MRF, LES, axial pressure.

Abstract: Stirred tank is one of the most important process-support tools in the industrial world, either in the food, pharmaceutical, oil or gas industries. The stirring process in a stirred tank involves miscible liquid stirring, gas dispersion or immiscible liquid into the liquid phase, suspension of solid particles, heat and mass transfer and chemical reactions. This research aims to study the characteristic of the stirring process by simulating the stir-equipped tank with water fluid that will be validated by experimentation that has been done. The stirring process is done by simulating computational fluid dynamics (CFD) using multiple reference frame (MRF) simulation method, modeling large eddy simulation (LES) flow turbulence and stirring speed variable. The stages in the simulation of the stirring process include pre-process, solving and post process. The simulation results have been validated by experiments conducted by Ivan Fort et al. The erosion at the bottom of the tank is predicted by observing the axial pressure distribution shown by the observation point.

1 INTRODUCTION

Stirred tanks are widely used for mixing of two miscible fluids in the chemical, food and process industries (Zadghaffari et al, 2008). In the various applications, stirred tanks are required to fulfill several needs like suspension of solid particles, dispersion of gases into liquids, heat and mass transfer, etc.

Agitation of solid-liquid system will caused erosion in apparatus wall stirred tank. Erosion on solid-liquid system have been studied by researcher such as *CFD simulation and experimental analysis of erosion in a slurry tank test rig* (Azimian and Bart, 2013) dan *Slurry Erosion in Complex Flows : Experiment and CFD* (Graham, Lester & Wu, 2009). Azimian et al (2013) have reported that hydro-

Computational modeling has always been presented as an option for the hydrodynamic analysis of such systems as it is far inexpensive and

erosion occurs in practice in two ways, one is the erosion by cavitations of liquid and on the other hand is the erosion by solid particles entrained in liquid flow known as slurry erosion.

Erosion rate is generally considered as the main function of influence particle rate, velocity and impact angle, so that the distribution of erosion rate depend on those factor. If the erosion is not equally distributed may cause tools damages. The uniform distribution will be achieved if the characteristic of erosion rate for geometrical agitated tank modification has known as a basic of engineering technology (Graham et al, 2009). The rate of erosion distribution can be determined from erosion model, which can be a very useful tool for prediction.

The study of detailed description of multiphase flow. CFD modelling, however, can only be applied after proper validation (Wadnerkar et al.,

2012). Therefore, CFD can be used to achieve characteristic of axial pressure distribution at stirred tank wall to predict the erosion rate. In an attempt to find a suitable computation technique for the hydrodynamics simulations, Fradette et al. (2007) assessed the accuracy of Shear-Induced Migration Model (SIMM) to capture the particle suspending phenomenon and particle migration in solid-liquid. Fort et al (2009) studied about the distribution of the local dynamic axial pressures along the flat bottom

of a pilot plant cylindrical mixing vessel equipped with four radial baffles and stirred with a four 45° pitched blade impeller pumping downwards. A set of pressure transducers is located along the whole radius of the flat bottom between two adjacent baffles. The radial distribution of the dynamic pressures indicated by the pressure transducers will be determined in dependence on the impeller off-bottom clearance and the impeller speed.

2 EXPERIMENTAL METHOD

This research simulated mixing of liquid system in stirred tank conducted from an experiment by Fort et al. (2009) with pitched blade turbine. Simulations carried out by ANSYS academic license which the method uses Large Eddy Simulation (LES) and Multiple Reference Frames (MRF) to describe turbulence flow in a stirred tank

The experiment uses a stirred tank fullgrid 3-D (360°) to get a flow pattern that approaches the actual conditions. The mixing simulation were conducted in a flat bottomed cylinder stirred vessel with inner diameter $T = 0.49$ m, agitated by a 4-blade 45° pitched blade turbine (PBT) of diameter $D = (2/5)T$. This vessel is equipped with four radial baffles ($b = 0.1 T$), as illustrated in Figure 1 and Table 1. The height of liquid was set at $H = T$ and

impeller off-bottom clearance were $T/4$ and $T/3$ with rotational speed 284 and 412 rpm. Materials used in the simulation of liquid system is water with room temperature. In this research to observe the axial pressure distribution at the bottom of the stirred tank, 10 observation points need to be made, as illustrated in Figure 2. The figure is adapted from Fort et al (2009) with configuration and point distance shown in Table 2.

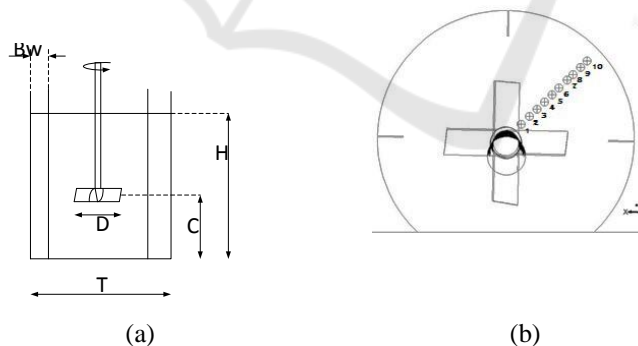

Figure 1: (a) Configuration Tank, (b) Bottom View of Observation Point.

Table 1: Configuration Tank.

Tank Diameter	Impeller Diameter	Baffle (B_w)	Liquid Height (H)	Lebar blade (W_b)	Tinggi hub
0.49 m	0.5 T	0.1 T	$H = T$	0.1 T	0.11 T

Table 2: Distance of Each Point in Bottom Vesel.

Point	1	2	3	4	5	6	7	8	9	10
Distance (cm)	4	6.2	8.2	10.2	12.2	14	16.2	17.7	19.7	21.5

3 RESULT AND DISCUSSION

Flow Pattern

Flow patterns distribution in a stirred tank are very important to know the circulation flow during the mixing process which will leads to an impact on mixing optimization. Observation of the flow pattern distribution is done by observing the flow direction that occurs during the mixing process produced by impeller. Simulated vector plots of the flow produced by the PBT using MFR and LES models are presented in Figures 3. Figure 2. shows the velocity vector due to flow turbulence that occurs during the mixing process because of the friction between the fluid and the tank wall. Variation of rotational speed affects the vector velocity produced. The high rotational speed and the longer mixing time would increase turbulence flow.

Based on Figure 2 also shows that the flow pattern generated from the simulation is in accordance with the flow pattern of the literature

(Wallas, 1990). However, for hydrodynamic fluid with various of Clearance has slightly different flow pattern (Mukhaimin et al., 2016). Clearance of T/4 can reach a maximum speed in the area of the tank that makes liquid easier to elevate from the bottom of the tank than T/3.

Axial Pressure Distribution

At the beginning, it is necessary to check the validity of the CFD code and the numerical method performed. In order to achieve the objective, we refer to the experimental work presented by Fort et al. [2]. With the same geometry (i.e. a baffled cylindrical vessel with a flat bottom), variations of the axial pressure along the vessel bottom are predicted and presented on Figure 3 and Figure 4. For purpose of validation, simulation results have been compared to experimental data for different clearance and rotational speed in the tank that shown below.

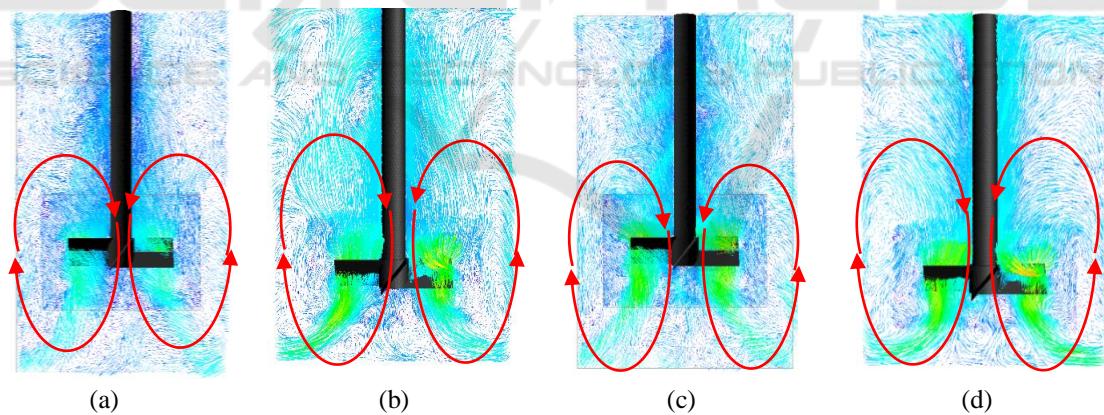

Figure 2: Flow Pattern (a) 284 rpm at Clearance T/3 (b) 284 rpm at Clearance T/4 (c) 412 rpm at Clearance T/3 (d) 412 rpm at Clearance T/4.

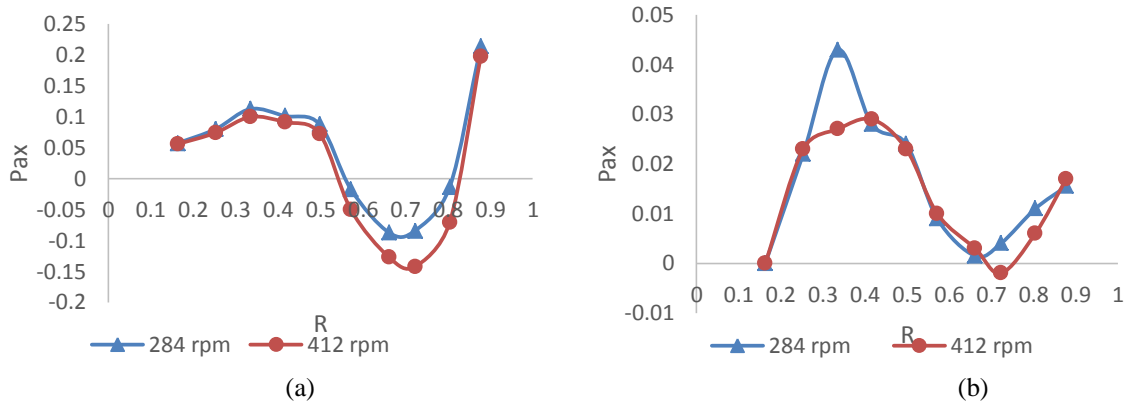

Figure 3: Data Axial Pressure Distribution at Clearance T/3 (a) Simulation Data (b) Experimental Data.

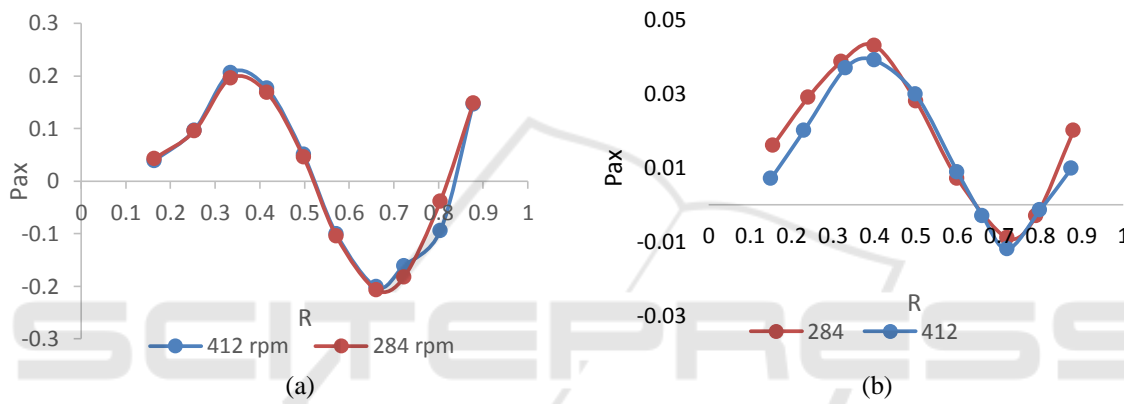

Figure 4: Data Axial Pressure Distribution at Clearance T/4 (a) Simulation Data (b) Experimental Data.

Figure 3. shows data of axial pressure distribution at clearance T/3, the simulation data showed that at R 0.57 to 0.8 axial pressure to Y negative axis direction in both impeller speed, where point at Y negative axis direction indicates an erosion. At impeller speed 412 rpm given axial pressure to Y negative axis direction bigger than impeller speed 284 rpm. Meanwhile, the experiment data shows that at impeller speed 284 rpm doesn't show any axial pressure to Y negative axis direction but have trend close to y negative axis direction between R 0.6 to 0.7, but impeller speed 412 rpm showed one point to Y negative axis direction at R 0.7. Based on the results, by increasing the impeller rotational, the speed of the turbulence flow and axial pressure distribution increases.

Figure 4. shows data of axial pressure distribution at clearance T/4 for simulation and experiment data. Simulation data shows that both impeller have 4 point at R 0.57 to 0.8 where axial pressure distribution to Y negative axis direction and experimental data shows 3 point at R 0.6 to 0.8 of

axial pressure distribution to y negative axis direction. Those point to Y negative axis direction shows that axial pressure distribution suppress to the vessel bottom and indicate erosion point. Triwibowo et al (2017) showed its all caused turbulence flow at stirred tank of static pressure in wall tank have stochastic direction.

Based on Figure 3 and Figure 4, axial pressure distribution data of simulation data and experimental data shows good agreement. Meanwhile, trend simulation data of axial pressure distribution at clearance T/4 result is much more similar to the experimental data rather than clearance T/3. The difference values between simulation data and experiment data result motivated us to improve the utilizations of CFD model. Some factors that were assumed in present calculation must be corrected in future study include time step size, number of iterations etc.

4 CONCLUSION

The models of simulation using MRF and LES used in the present CFD simulation demonstrated an alternative method for experimental method. The effect of clearance showed that clearance T/4 can reach a maximum speed which allow the liquid to elevate much more easier from the bottom of the tank, compare to T/3. Besides that, simulation data of axial pressure distribution at clearance T/4 closer to experiment data. Reasonable agreement between experimental and simulation results was obtained. The satisfactory comparisons indicate the potential usefulness of this CFD approach as a computational tool for designing stirred tank.

REFERENCES

- Azimian, M & Bart, H., 2013. "CFD Simulation and Experimental Analysis of Erosion in a Slurry Tank Test", *EPJ Web of Conferences*, Vol. 45, pp. 1-8.
- Fort, I., Hasal, P., Apiglianti, A., & F. Magelli. 2009. "Axial Force at the Vessel Bottom Induced by Axial Impellers". *Acta Polytechnica*. Vol. 48, No. 4, pp. 45-50.
- Fradette, L., Thome, G, Tanguy, P.A., & Takenaka, K., 2007. "Power and Mixing Time Study Involving a Maxblend Impeller with Viscous Newtonian and Non-Newtonian Fluids". *Journal of Chemical Engineering Research and Design*, Vol. 85, pp. 1514-1523.
- Graham, L.J.W., Lester, D., & Wu, J., 2009. "Slurry Erosion in Complex Flows: Experiment and CFD. *Seventh International Conference on CFD in the Minerals and Process Industries CSIRO*, Melbourne, Australia 9-11 December 2009.
- Triwibowo, B, Megawati, Puspita, D.R., & Putri, D. A., 2017. "Simulasi Distribusi *Shear Stress* pada Dasar Tangki Sistem Pengadukan Berbasis *Computational Fluid Dynamics (CFD)*". *Jurnal Kompetensi Teknik*, Vol 9, pp. 20-28.
- Wadnerkar, D., Utikar, R., Tade, M., and Pareek, V. 2012. "Simulation of solid-liquid flow in stirred tanks at high solid loading, in Solnordal, C.B. et al (ed), *Ninth International Conference on CFD in the Minerals and Process Industries*, Dec 10-12 2012, pp. 1-7. CSIRO, Melbourne: CSIRO.
- Zadghaffari, R., Moghaddas, J.S., Ahmadlouydarab, M., & Revstedt, J., 2009. "A mixing study in a double-Rushton stirred tank". *Computers & Chemical Engineering*, Vol. 33, Issue 7, pp. 1240-1246.