



# Machine Learning Approach for Live Migration Cost Prediction in VMware Environments

Mohamed Esam Elsaid<sup>1</sup> <sup>a</sup>, Hazem M. Abbas<sup>2</sup> <sup>b</sup> and Christoph Meinel<sup>1</sup> <sup>c</sup>

<sup>1</sup>*Internet Technologien und Systeme, Hasso-Plattner Institut, Potsdam Uni., Potsdam, Germany*

<sup>2</sup>*Dept. Computer and Systems Engineering, Ain Shams University, Cairo, Egypt*

**Keywords:** Cloud Computing, Virtual, Live Migration, VMWare, vMotion, Modeling, Overhead, Cost, Datacenter, Prediction, Machine Learning.

**Abstract:** Virtualization became a commonly used technology in datacenters during the last decade. Live migration is an essential feature in most of the clusters hypervisors. Live migration process has a cost that includes the migration time, downtime, IP network overhead, CPU overhead and power consumption. This migration cost cannot be ignored, however datacenter admins do live migration without expectations about the resultant cost. Several research papers have discussed this problem, however they could not provide a practical model that can be easily implemented for cost prediction in VMware environments. In this paper, we propose a machine learning approach for live migration cost prediction in VMware environments. The proposed approach is implemented as a VMware PowerCLI script that can be easily implemented and run in any vCenter Server Cluster to do data collection of previous migrations statistics, train the machine learning models and then predict live migration cost. Testing results show how the proposed framework can predict live migration time, network throughput and power consumption cost with accurate results and for different kinds of workloads. This helps datacenters admins to have better planning for their VMware environments live migrations.

## 1 INTRODUCTION

Live migration of virtual machines is a key feature in virtual environments, private and public cloud computing datacenters. Using live migration, virtual machines can be moved from a physical host to another while the applications are running online. This is due to the negligible service interruption during the migration process. Servers load balance, power saving, fault tolerance and dynamic virtual machines allocation are all dependent on live migration (Choudhary et al., 2017). During the live migration process, the VM CPU cache, memory pages and IO buffers contents are migrated. However the storage content is shared between the source and the target servers, so storage content is not migrated. Live migration is supported by VMware (vMotion), Xen (XenMotion), Microsoft Hyper-V and KVM.

Live Migration cost can be classified into performance of migration and performance loss of VM and

energy overhead (Strunk, 2012). Performance of migration includes the migration time and the downtime that is consumed during a live migration process. Performance loss of VM includes the overhead of the migration process on the servers CPU, memory and network throughput. And finally the energy overhead in Joule or the power consumption overhead in Watt due to live migration. As we will discuss in section II, the live migration cost is variable with VM memory size, network utilization, CPU utilization and the dirty pages rate which depends on the running workload. For the best of our knowledge, until now live migration is done by datacenter admins with no expectations about the migration cost. So the admins do the live migrations and then see the impact of it on the network, CPU, memory and power consumption. This leads sometimes to facing failures in live migration, bottlenecks in the datacenter infrastructure resources, and downgrade in the VMs availability due to longer down time especially for large memory VMs migrations.

In this paper, we propose a practical machine learning framework for live migration cost modelling and prediction in VMware environments. The pro-

<sup>a</sup>  <https://orcid.org/0000-0003-1577-5290>

<sup>b</sup>  <https://orcid.org/0000-0001-9128-3111>

<sup>c</sup>  <https://orcid.org/0000-0002-3212-6201>

posed framework starts with data collection about the history of live migrations that have run in the cluster during the past 12 hours, then use the collected statistics for models training. After training the models, the prediction phase can start to estimate the future live migration requests cost. This should help the datacenters admins to estimate the cost of single or multiple VMs live migration before proceeding with it. This means better live migration tasks planning and less resources bottlenecks.

The rest of this paper is structured as following. In section II, we discuss in details the live migration cost. In section III, the related research work is discussed. The proposed prediction technique is presented in section IV. The the modeling results are analyzed in section V. Then we conclude the paper in section VI.

## 2 LIVE MIGRATION COST

Live migration consists of mainly six phases; initialization, reservation, iterative pre-copy, stop-and-copy, commitment and activation (Elsaid and Meinel, 2014). The cost of live migration is actually a result of passing through these six phases. In this paper, we focus on modeling and predicting the below migration cost parameters as main overhead costs that can be measured in our test-bed and modeled with regression techniques:

- **Migration Time:** This is the time consumed in seconds from the migration request initiation until having the VM activated at the destination host. This is the time consumed by the above 6 phases of the pre-copy migration.
- **Network Overhead:** This is the increase in the IP network throughput in kBps due to the VM content migration from the source host to the target one.
- **Power Consumption:** live migration process consumes significant energy. This is due to the increase in CPU and network utilization. In this paper, we model and predict the peak power overhead in Watt.

The CPU and down time cost parameters will be considered in an extended work to this paper.

## 3 RELATED WORK

Live Migration cost is analyzed by different mathematical and empirical methods. Analysis and Prediction of live migration cost is presented using machine

learning, or mathematical approaches. In our paper (Elsaid and Meinel, 2014), we have provided empirical models for live migration time, network overhead and power consumption in relation with the VM active memory size for VMware vMotion. Cost prediction could not be used in (Elsaid and Meinel, 2014) due to the constants in the provided models. These constants depend on the cluster characteristics like CPU models and network bandwidth. This work is an extension of the previous work in (Elsaid and Meinel, 2014); where the contribution is providing a machine learning based approach for live migration cost estimation. Machine learning is used mainly to define the constants in the provided models in (Elsaid and Meinel, 2014) during the training phase, and then the empirical models are used to predict the VM migration cost.

In Reference (Hu et al., 2013), an analysis of live migration time and downtime is provided and then a comparison between Xen, KVM, Hyper-V and VMware vSphere hypervisors is presented in terms of storage migration and live migration time and downtime. A comparison between Xen and VMware live migration time and downtime is also presented in (Salfner et al., 2011) with more investigation on the parameters that control the live migration time and downtime durations. The authors (Bezerra et al., 2017) show the impact of a VM live migration on the running applications performance from client side. The performance degradation of the application from client side was measured in operations per second. The impact of live migration on Internet Web 2.0 applications performance is discussed in (Voorsluys et al., 2009). This is important for environments with SLA requirements. For this purpose, a test-bed is built in (Voorsluys et al., 2009) where the running Web 2.0 workload is Olio application, combined with Faban load generator that access the Apache 2.2.8 Web server with MySQL database.

The other category of papers focus on live migration cost prediction. Classification of Live migration cost is provided in (Strunk, 2012) with an explanation of the parameters that control migration time, downtime and energy consumption. Also, Mathematical models are proposed to estimate live migration time, downtime and energy consumption. Machine learning is used in (Berral et al., 2013) for VM placement elements predictive modeling like (CPU, memory, network and energy). The authors (Akoush et al., 2010) analyze the parameters that control the migration time and the downtime and show the impact of the workload on the migration performance. Markov chains are used in (Melhem et al., 2018) for hosts utilization prediction after live migration. The proposed Markov

Table 1: Summary of Related Work.

Paper	Research Scope	Migration Time	Down Time	CPU	Network	Power	Hypervisor
(Elsaid and Meinel, 2014)	Analysis	X	-	-	X	X	VMware
(Hu et al., 2013)	Analysis	X	X	-	-	-	VMware/ Xen/ Hyper-v/ KVM
(Salfner et al., 2011)	Analysis	X	X	-	-	-	Xen / VMware
(Voorsluys et al., 2009)	Analysis	X	X	-	-	-	Xen
(Strunk, 2012)	Prediction	X	X	-	-	X	Xen
(Zhao and Figueiredo, 2007)	Prediction	X	-	-	-	-	VMware but not vMotion
(Berral et al., 2013)	Prediction	-	-	X	X	X	Oracle Virtual Box
(Jo et al., 2017)	Prediction	X	X	X	X	-	VMware/ Xen/ Hyper-v/ KVM
(Akoush et al., 2010)	Prediction	X	X	-	-	-	Xen
(Salfner et al., 2012)	Prediction	X	X	-	-	-	VMware/ Xen/ KVM
(Melhem et al., 2018)	Prediction	X	-	-	-	-	-
(Huang et al., 2014)	Prediction	X	-	X	X	X	Xen
(Aldossary and Djemame, 2018)	Prediction	X	-	X	-	X	KVM

based prediction model is used for power saving algorithm that can achieve lower SLA violations, lower VM migrations as well as less power consumption (Melhem et al., 2018). Time series is used in (Huang et al., 2014) for time varying resources load prediction. The proposed model is used for power saving by minimizing the number of active physical machines with less live migration times and with satisfying the SLA requirements. The proposed technique is tested in a Xen cluster. A mathematical based prediction framework is also proposed in (Aldossary and Djemame, 2018). From Table I, the papers that focus on VMware cost prediction are (Zhao and Figueiredo, 2007), (Jo et al., 2017) and (Salfner et al., 2012). To the best of our knowledge, using machine learning for VMware live migration cost prediction is not covered in a practical way by any of these papers; which is the point that we cover in this paper by the proposed machine learning approach. We discuss the shortage in practicality of papers (Zhao and Figueiredo, 2007), (Jo et al., 2017) and (Salfner et al., 2012) in the following points:

- In paper (Zhao and Figueiredo, 2007), a VMware cluster is built for modeling, but vMotion is not used. The authors could do the suspend, copy and resume operations manually for migration time prediction. This limits the proposed modeling to be used practically in an enterprise environments that use vMotion by default as the live migration feature in vSphere; without any manual operations.
- The machine learning approach proposed in (Jo et al., 2017) can be used for most of the live migration algorithms in different hypervisors as stated

in (Jo et al., 2017). However, the proposed machine learning technique depends on massive empirical tests for 40,000 live migration that were run in order to have accurate prediction. This means that the approach used for live migration cost prediction will generate an intensive cost itself; which blocks the ability to practically implement the proposed approach in (Jo et al., 2017).

- In the proposed mathematical model in (Salfner et al., 2012), live migration time and downtime can be predicted but after the start of the live migration; not before. This means that the proposed algorithm does not help the cluster admin to know the live migration cost before proceeding with migration.

In the next section, we discuss our paper contribution in more details.

## 4 PROPOSED COST PREDICTION FRAMEWORK

In this paper, we solve the challenge of having a practical live migration cost prediction for VMware environments. This is achieved by proposing a machine learning based approach that is implemented as VMware PowerCLI script and can connect to any VMware vCenter server to train the model and then predict live migration cost. Here, we list our contribution in this paper in the following points:

- We propose a machine learning approach for VMware vMotion that predicts the live migration time, network overhead and power consumption given the active memory size of the VM.

- The proposed approach can be practically used. It is implemented as a VMware PowerCLI script; that can be bounded with any VMware vCenter server and show the cost prediction results.
- The proposed script includes data collection that is used for the models training phase. This makes the proposed models adaptable to each VMware cluster automatically.
- The training phase in the proposed machine learning algorithm is fed by the ongoing live migration operations that run in the datacenter; which increases that the prediction accuracy.

#### 4.1 Modelling of Live Migration Cost

This paper is an extension to the proposed models in (Elsaid and Meinel, 2014) and (Elsaid and Meinel, 2016). From these papers, the following empirical models could be proposed for live migration time, data rate and power consumption after applying the regression techniques:

- The relation between the network rate and the active memory size can be modelled as an exponential relation; as shown in equation (1).

$$R_s = \alpha e^{V_{Mem}} + \beta \quad (1)$$

$R_s$ : is the source host network throughput overhead in kbps,  $V_{mem}$  is the source host active memory size in kB at the time when the live migration should start.  $\alpha$  and  $\beta$  are the equation constants. From equation (1).

- Migration Time: A linear relationship is obtained between the migration time and the division of the memory size over the transmission rate; as represented in equation (2).

$$T_{mig} = a \cdot \left( \frac{V_{mem}}{R_s} \right) + b \quad (2)$$

$T_{mig}$  is the migration time duration in seconds.  $a$  and  $b$  are the equation constants.

- Peak power consumption overhead has linear relation with the transmission rate; as represented in equation (3).

$$P_{mig} = \frac{dE_{mig}}{dt} = c \frac{dV_{mig}}{dt} = c R_s \quad (3)$$

$P_{mig}$  is the peak power overhead in Watt, and  $c$  is constant. From equation (3).

In our previous papers, the above models could be used for cost analysis but not for cost prediction. This is because of the equations constants. These constants depend on the cluster hardware configuration

like CPU specs, so they change from a cluster environment to another. So in order to determine these constants and achieve higher accuracy in cost prediction, we propose a machine learning framework to predict the live migration cost.

#### 4.2 Machine Learning based Cost Prediction

In this paper, machine learning is used because the proposed models in equations (1 - 3) can not be used in live migration cost prediction. This is due to the constants included in the equations. These constants values depend on the cluster hardware characteristics; like CPU and network configurations. So, machine learning is needed to train the models in reference to equations (1 - 3) until the constants values are obtained for each cluster. Then, these equations can be used for cost prediction. In this section, we present the proposed machine learning based framework for live migration time, transfer rate and power consumption overhead prediction. As shown in the flow chart of Fig. 1, the proposed framework consists of two main phases, the training phase and the prediction phase. The training phase starts when the VMware PowerCLI script connects to the cluster vCenter Server Appliance (vCSA). Then data collection starts with listing all the events happened in the cluster during the last 12 hours. This 12 hours cycle can be changed based on the cluster admin preference. From the collected events, vMotion events are filtered out. These vMotion events details like the source host, target host and time stamp are captured. Then the script calculates the complete and start time differences in order to get the migration time of each vMotion request. The performance logs of vCSA are collected at the start and the completion times at the vMotion events in order to get the active memory size of the migrated VMs in kB, the network overhead in kbps and the peak power change in Watt.

From the above data of each vMotion event, we use the regression models in equations (1 - 3) to calculate the equations constants after doing several substitution and considering the minimum Root Mean Square Error (RMSE); equation (4).

$$RMSE = \sqrt{\frac{1}{N} \sum_{i=1}^N (d_i - f_i)^2} \quad (4)$$

Where  $N$  is the number of sample points collected during the last 12 hours.  $d_i$  is the measured performance value and  $f_i$  is the regression equation value.

If the change in all the constants value became greater than 10% of the last 12 hours cycle, the script waits for more 12 hours and run again to continue in

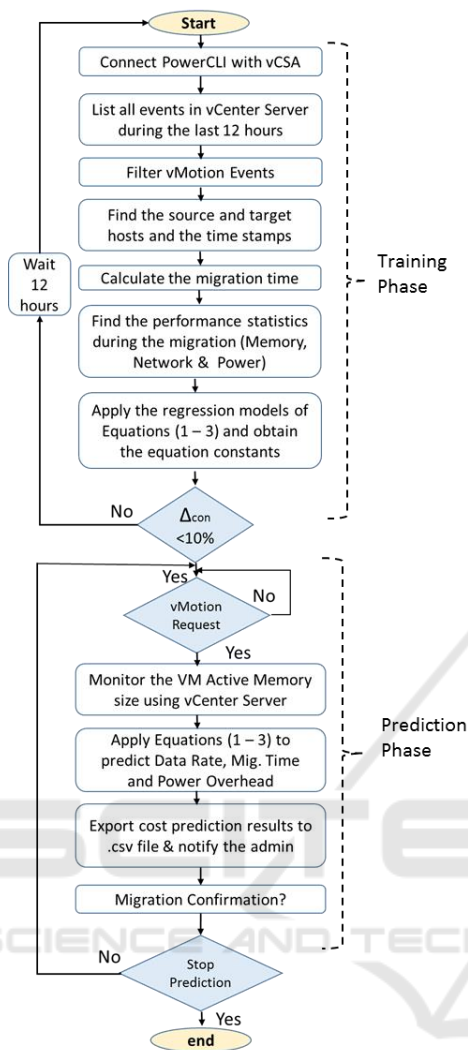

Figure 1: Proposed Prediction Framework.

the training phase. If these changes became less than 10% of the last 12 hours, so we consider the the training phase of this cluster is finished, and the script then moves to the prediction phase. The time consumed until reaching this 10% convergence depends on the changes that happen in the VMs active memory size; which depends on the running workload. This sequence of data collection and models training makes the algorithm can fit at any vCenter Server cluster and adapt its models based on the cluster configuration in order to provide cost prediction.

In the prediction phase when a vMotion request is sent by the cluster admin, the active memory size is captured by the script before proceeding with live migration. Once the active memory size is known, equation (1) is used to predict the source host network throughput. Then equation (2) is used to predict the migration time, and finally equation (3) is used to

predict the peak power consumption. The prediction data is exported to a .csv file that the cluster admin can read, and decide to proceed with this migration or not.

## 5 TESTING ENVIRONMENT

The testing environment is shown in Fig. 2; as shown it has a similar infrastructure to enterprise datacenters. It includes the following hardware setup; Three Hosts (Hewlett Packard DL980 G7) with 8 x Intel Xeon (Nehalem EX) X7560, 8GB RAM, 4 NICs, 2 HBA with 2 Fiber ports per card. The three hosts are connected to a shared storage EMC VNX5800; 1TB LUN via FC-SAN network. The Ethernet switch is Cisco with 1Gbps ports. From software prospective, VMware ESXi 6.5.0 Hypervisor is used with vCenter Server that manages both hosts and the VMs live migration. VMware PowerCLI 6.5.1 build 5377412 is connected to the vCenter Server to run the framework algorithm script.

In this set up we have created four Linux Ubuntu 12.04 VMs with 4 vCPU, and different RAM sizes (1GB, 2GB, 4GB and 8GB). The VMs have mainly 3 categories of workload:

- CPU and Memory intensive: This is considered as the worst case scenario for a running workload. The CPU intensive benchmark that we used is Linpack (Lin, ) and the memory stress is the Linux *Stress* Package (Mem, ).
- Network Intensive: The network stress benchmark that we have used is Apache Bench (AB). Apache Bench tool stresses the web servers with lots of requests through the network to test the servers response.
- Idle: VM is simply an idle Ubuntu OS VM; with no running applications.

With this testing setup, we have run 12 testing scenarios; as a matrix of 3 workload categories and 4 different VM sizes. For each configuration, we have run live migration at least 10 times.

## 6 RESULTS AND ANALYSIS

After testing the proposed approach in Fig. 1 on the test-bed of Fig. 2, we present in this section the prediction results for almost 144 readings. We start with the training phase to show how the models are trained until obtaining equations (1 - 3) constants with at least 90 percent accuracy.

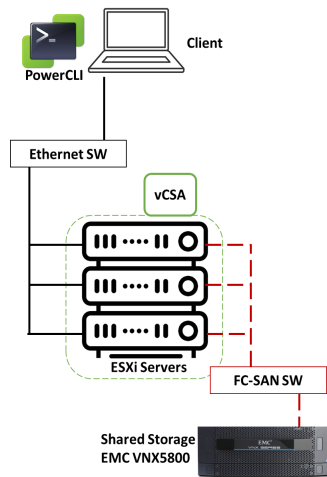

Figure 2: Testing Lab Layout.

### 6.1 Training Phase

In this phase, the script collects the last 12 hours live migration events. Then the performance statistics of these live migrations are gathered including their time stamps. The migration time is calculated by the script; given the start and end time of the live migration event. The other gathered statistics include the active memory size, the source host transmission rate and the peak power change. All these details are used to train the models of equations (1 - 3) and to obtain the constants of this cluster by solving several linear equations. For example in order to calculate  $a$  and  $b$  of equation (2), we use every two live migration events statistics to generate two equations in two unknowns. These unknowns are  $a$  and  $b$  in this example, because the migration time, the active memory size and the transmission rate are given. So, we gather every two live migration events statistics to solve for the constants of equation (2). The script keeps on solving for the values of  $a$  and  $b$  until finding the changes in the values of  $a$  and  $b$  are less than 10 percent compared to the calculated values of last equations solution. Fig. 3 shows the changes of  $a$  and  $b$  constants versus the number of live migration equations that were used until reaching the 90 percent saturation. As shown in Fig. 3; the difference in  $a$  is changing with the number of live migrations which represents solving more equations until the 90 percent saturation at difference equals 0.22 after 14 live migrations. At this point  $a=9.04$ . For  $b$  constant, the script has run 50 live migrations to reach the 90 percent saturation at difference equals 9.16. At this point  $b=21.04$ . This means that modeling with equation (2) could be used after 50 live migration runs for this cluster. For equation (1), we could also solve every two equations of live mi-

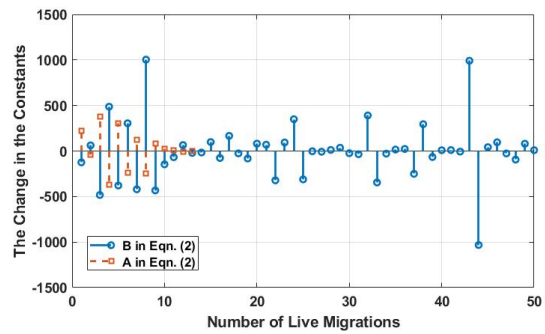

Figure 3: A and B Change until Saturation.

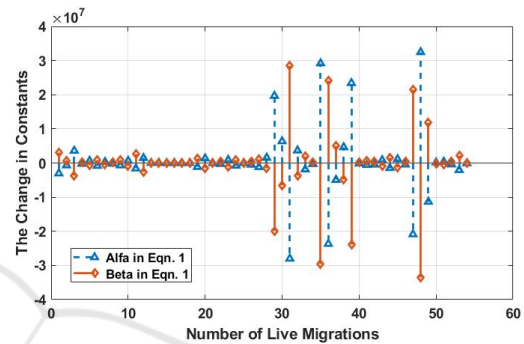

Figure 4: Alpha and Beta Change until Saturation.

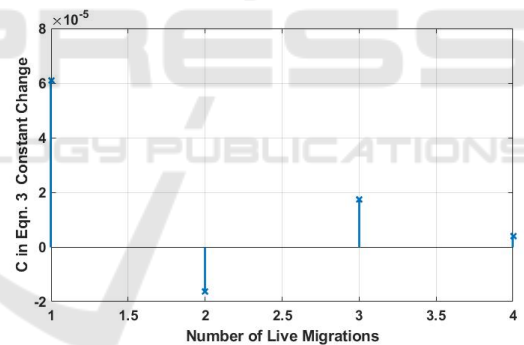

Figure 5: C Change until Saturation.

grations data as linearly to obtain the values of  $\alpha$  and  $\beta$ . This is because the values of the active memory size and the migration time are given, so we can substitute with them and then solve two equations in two unknowns;  $\alpha$  and  $\beta$ . Fig. 4 shows the differences happen in the values of  $\alpha$  and  $\beta$  after each live migration until reaching the 90 percent saturation. As shown; the constant  $\alpha$  could reach the saturation at difference equals 1850 after 54 live migrations. At this point  $\alpha$  equals  $2.02 \times 10^4$ . The value of  $\beta$  reaches the 90 percent saturation at difference equals 2225 also after 54 live migrations. At this point,  $\beta$  equals  $2.33 \times 10^4$ . This means that modeling with equation (1) can be used after 54 live migration runs. Finally, equation (3), which has just one unknown;  $c$  and so it can be resolved given just one live migration statistics. So

for each live migration run in the past 12 hours, we could read the transmission rate and the peak power overhead and then calculate the constant  $c$ . Fig. 5 shows the changes happen with each live migration calculation to the the constant  $c$ ; as shown it 90 percent saturates after just four live migrations runs at difference of  $c$  value equals  $0.6 * 10^{-5}$ . At this point  $c$  equals  $16 * 10^{-5}$ . From the above analysis, we find that it required 54 live migration runs to be able to train the models provided in equation (1 - 3). In general, the required number of live migrations runs to finish the training phase depends on the error gap between the training data and the regression model.

### 6.2 Prediction Phase

In this subsection, we build on the training phase that we have discussed above. Now, the regression models are trained for this cluster and ready to be used for future live migration cost prediction. The testing results in Fig. 6 - 8, show the regression models that are used and the actual measured data after migration. The measurement points in Fig. 6, Fig. 7 and Fig. 8 are VMs live migrations with different configurations including memory size of 1GB, 2GB, 4GB and 8GB VMs that utilize three different kinds of workloads. As discussed in section V, these workloads are CPU and memory intensive, network intensive and idle VMs. This results in 12 different VM configurations. Each configuration is tested 12 times; which represents the existing 144 measurement points in the following figure. The prediction starts with Fig. 6; so given the active memory size of the VM to be migrated, the source host transmission rate can be predicted. The VM active memory size can be measured before live migration. Fig. 6 shows the exponential relation as a valid regression model between the active memory size and the transmission rate. Table II shows the RMSE of Fig. 6 in reference to equation (4). After obtaining the transmission rate from Fig. 6, we calculate now the active memory size over the transmission rate; which is the horizontal axis of Fig. 7. So the migration time can be predicted; using the linear regression model of Fig. 7. The RMSE of the prediction in Fig. 7 is also listed in Table II. Fig. 7 also shows that the migration time can consume several minutes in case of large memory and memory intensive VMs. The last model is for the source host peak power change; which is shown in Fig. 8. So given the source host transmission rate, the peak power change can be obtained.

All these predicted live migration cost parameters are exported to a .csv file that can be accessed by the cluster admin to check the estimated cost if he/she

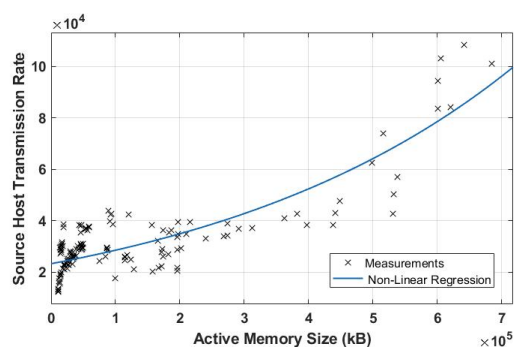

Figure 6: Rate vs Active Memory Size.

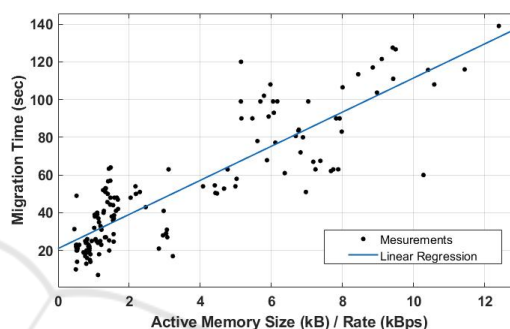

Figure 7: Migration Time vs Active Memory Size/Rate.

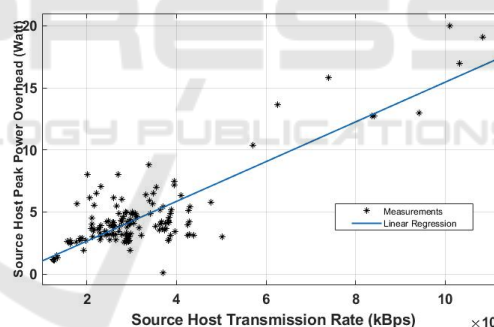

Figure 8: Peak Power Overhead vs Transmission Rate.

decides to do live migration to a certain VM. This help the admins to have better planning for live migrations. This proposed framework script can adapt itself by changing the models constants using the training phase; which make it flexible with any VMware cluster.

Table 2: RMSE of the Regression Models.

Model	Fig.	RMSE
Transmission Rate	Fig. 6	8187
Migration Time	Fig. 7	15.5
Peak Power	Fig. 8	1.7

## 7 CONCLUSION

Live migration cost can not be ignored and might lead to resources bottlenecks, service availability degradation and live migration failures. Several related papers have discussed this problem by applying mathematical and empirical studies, however to the best of our knowledge there is no related paper that could provide a practical approach that can be used and integrated with VMware clusters. In this paper, we proposed a practical machine learning based approach that helps the datacenter admins to predict the live migration cost in VMware environments. The proposed framework is implemented as VMware PowerCLI script and can connect to any vSphere vCenter Server. We considered simplicity in the proposed approach to minimize the CPU consumption overhead due to running the proposed approach and so make it agile enough to be implemented in enterprise datacenters. In this paper, we predict the live migration time, network throughput and power consumption overhead. Testing results show that the proposed regression based models can be used for cost prediction with acceptable error.

## REFERENCES

- <https://people.seas.harvard.edu/~apw/stress/>  
[www.netlib.org/linpack/](http://www.netlib.org/linpack/).
- Akoush, S., Sohan, R., Rice, A., Moore, A. W., and Hopper, A. (2010). Predicting the performance of virtual machine migration. In *Proceedings of the 2010 IEEE International Symposium on Modeling, Analysis and Simulation of Computer and Telecommunication Systems*, MASCOTS '10, pages 37–46, Washington, DC, USA. IEEE Computer Society.
- Allossary, M. and Djemame, K. (2018). Performance and energy-based cost prediction of virtual machines live migration in clouds. In *Proceedings of the 8th International Conference on Cloud Computing and Services Science, CLOSER 2018, Funchal, Madeira, Portugal, March 19-21, 2018.*, pages 384–391.
- Berral, J. L., Gavaldà, R., and Torres, J. (2013). Power-aware multi-data center management using machine learning. In *Proceedings of the 2013 42Nd International Conference on Parallel Processing, ICPP '13*, pages 858–867, Washington, DC, USA. IEEE Computer Society.
- Bezerra, P., Martins, G., Gomes, R., Cavalcante, F., and Costa, A. (2017). Evaluating live virtual machine migration overhead on client's application perspective. In *2017 International Conference on Information Networking (ICOIN)*, pages 503–508.
- Choudhary, A., Govil, M. C., Singh, G., Awasthi, L. K., Pilli, E. S., and Kapil, D. (2017). A critical survey of live virtual machine migration techniques. *J. Cloud Comput.*, 6(1):92:1–92:41.
- Elsaid, M. E. and Meinel, C. (2014). Live migration impact on virtual datacenter performance: Vmware vmotion based study. In *2014 International Conference on Future Internet of Things and Cloud*, pages 216–221.
- Elsaid, M. E. and Meinel, C. (2016). Multiple virtual machines live migration performance modelling – vmware vmotion based study. In *2016 IEEE International Conference on Cloud Engineering (IC2E)*, pages 212–213.
- Hu, W., Hicks, A., Zhang, L., Dow, E. M., Soni, V., Jiang, H., Bull, R., and Matthews, J. N. (2013). A quantitative study of virtual machine live migration. In *Proceedings of the 2013 ACM Cloud and Autonomic Computing Conference, CAC '13*, pages 11:1–11:10, New York, NY, USA. ACM.
- Huang, Q., Shuang, K., Xu, P., Liu, X., and Su, S. (2014). Prediction-based dynamic resource scheduling for virtualized cloud systems. *JNW*, 9:375–383.
- Jo, C., Cho, Y., and Egger, B. (2017). A machine learning approach to live migration modeling. In *Proceedings of the 2017 Symposium on Cloud Computing, SoCC '17*, pages 351–364, New York, NY, USA. ACM.
- Melhem, S. B., Agarwal, A., Goel, N., and Zaman, M. (2018). Markov prediction model for host load detection and VM placement in live migration. *IEEE Access*, 6:7190–7205.
- Salfner, F., Tröger, P., and Polze, A. (2011). Downtime Analysis of Virtual Machine Live Migration. In *The Fourth International Conference on Dependability*, pages 100–105. IARIA, IARIA.
- Salfner, F., Tröger, P., and Richly, M. (2012). Dependable Estimation of Downtime for Virtual Machine Live Migration. *International Journal On Advances in Systems and Measurements*, 5:70–88.
- Strunk, A. (2012). Costs of virtual machine live migration: A survey. In *Proceedings of the 2012 IEEE Eighth World Congress on Services, SERVICES '12*, pages 323–329, Washington, DC, USA. IEEE Computer Society.
- Voorluis, W., Broberg, J., Venugopal, S., and Buyya, R. (2009). Cost of virtual machine live migration in clouds: A performance evaluation. In *Proceedings of the 1st International Conference on Cloud Computing*, CloudCom '09, pages 254–265, Berlin, Heidelberg. Springer-Verlag.
- Zhao, M. and Figueiredo, R. J. (2007). Experimental study of virtual machine migration in support of reservation of cluster resources. In *Proceedings of the 2Nd International Workshop on Virtualization Technology in Distributed Computing, VTDC '07*, pages 5:1–5:8, New York, NY, USA. ACM.