

# Design of a Small-sized Simple Printed Circuit Board Engraving Machine

Kai Zheng<sup>1, a</sup>, Jiangping Nan<sup>2, b</sup>

<sup>1</sup>Department of Electrical Engineering, Xi'an Traffic engineering Institute, Xian city, Shaanxi Province, China

<sup>2</sup>Department of Electrical Engineering, Xi'an Traffic engineering Institute, Xian city, Shaanxi Province, China

**Keywords:** Table engraving machine, machine design, control system.

**Abstract:** What this design has developed is kind of simple PCB CNC engraving machine for personal and school laboratories (hereinafter referred to as: engraving machine). According to the requirement of system design, the design scheme of main motion and feed motion of engraving machine is fully demonstrated. The system consists of mechanical part and control part. The mechanical part adopts vertical structure and calculates the design parameters according to the working requirements of the system. The control part takes PC as the control core to design the control hardware module. The open-loop servo system with simple structure, stable operation, easy control and convenient maintenance is adopted.

## 1 INTRODUCTION

With the rapid development of computer technology, the engraving machine system which combines CNC technology with traditional engraving machine has been widely used. However, no matter foreign or domestic CNC engraving machine systems, a large part of them are dedicated apparatus, which are expensive and not easy to maintain, to a certain extent, hindering the development of engraving technology (Chen Jianning, J., 2016). For the sake of meeting the demands of the market product line, we have developed a small-sized and simple printed circuit board engraving machine based on the support of Mach3 software and computer platform.

## 2 OVERALL DESIGN SCHEME OF ECONOMICAL TABLE ENGRAVING MACHINE

### 2.1 The Design Objective of the Engraving Machine

At present, printed circuit board (PCB) is mainly processed by chemical etching method in practical processing. Processing with traditional chemical etching method not only increases labor intensity,

but also complicates the processing technology. The processing efficiency cannot be guaranteed and the environmental pollution and material loss are greater. Therefore, a new processing method and equipment are needed.

During the past half century, the PCB manufacturing industry has been developing continuously from small to large, from low to high level, especially the development of household appliances in the 1980s and the boost of information industry in the 1990s, which has greatly pushed forward the development of the entire PCB industry. The manufacture of PCB has been is becoming more and more miniaturized, refined and diversified. For the sake of meeting the development of the market and the high-end demand, the engraving machine should not only meet the manufacturing requirements of the engraving machine, but also simplify the mechanical structure on the premise of improving the economy. Computer parallel port communication technology and control software are used to design and manufacture an economical table engraving machine with simple mechanism, high precision, easy control and convenient maintenance.

### 2.2 Composition of Control System of Engraving Machine

The main control module of this system adopts the mainstream mode of PC + control software; The

feed system adopts the combination of stepping motor and driver to drive the motion of each axis (Fan Chaoyi, Fan Wei, J, 2018); The spindle motor adopts DC motor and the most widely used PWM pulse width modulation technology to realize the drive and speed regulation of spindle motor; In addition, it also includes power module and auxiliary module of engraving machine. The control system schematic diagram is shown as Figure 1.

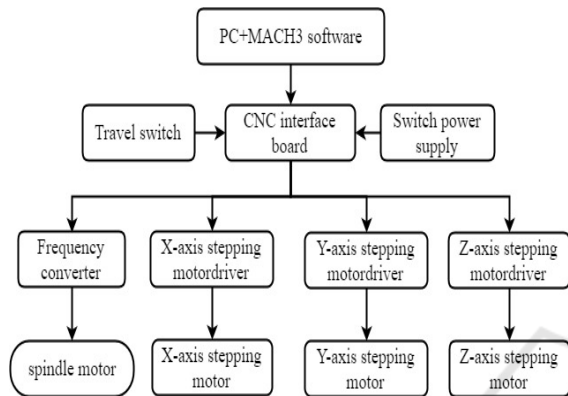

Figure 1. Control system schematic diagram.

### 2.3 Composition of Mechanical System of Engraving Machine

This item consists of post, base, spindle, worktable and X, Y, Z three-axis executive parts, each executive part includes (stepping motor, ball screw, sliding plate). The correlations between them are that there are post above the base, Z-axis executive part on the post, and spindle, pulley mechanism and electric motor on the Z-axis sliding plate. A cross sliding platform consisting of X-axis and Y-axis executive parts is installed above the bottom plate. The outer ends of X-axis, Y-axis and Z-axis ball screws are respectively connected with X-axis, Y-axis and Z-axis stepping motors through coupling. The engraving tool is installed on the spindle, a worktable is arranged below it, and the worktable is installed on the X-axis sliding plate. The mentioned spindle adopts a unpowered spindle, which can be connected with an electric motor through a pulley mechanism to provide power for the spindle's rotational motion. This vertical structure ensures the requirements of simple structure, low cost, easy processing and assembly of the engraving machine. The mechanical structure of the system is shown as Figure 2.

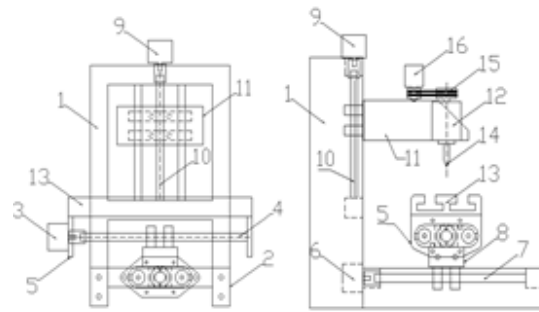

Figure 2. System mechanical structure.

1-post, 2-base, 3, 6, 9-stepping motor, 4, 7, 10-Screw rods of each axis, 5, 8, 11-sliding plates of each axis, 12-unpowered spindle, 13-work table, 14-tool, 15-Pulley mechanism, 16-Electric motor

## 3 OVERALL DESIGN SCHEME OF ECONOMICAL TABLE ENGRAVING MACHINE

### 3.1 Design Parameters of Engraving Machine

According to the requirement of the working scene of the engraving machine, the design indicators of the engraving machine is worked out. Specific indicators are shown as Table 1.

Table 1. Design indicator parameter table of engraving machine.

Item	Parameter	Unit
Spindle maximum speed	24000	r/min
Maximum feed speed	3000	mm/min
X-axis travel	200	mm
Y-axis travel	260	mm
Z-axis travel	70	mm
positioning accuracy	0.05	mm
Pulse equivalent	0.01	mm
Service life	15000	hrs

### 3.2 The Technical Scheme of Engraving Machine Design

For the sake of the design of a kind of small-sized and simple printed circuit board engraving machine (hereinafter referred to as: engraving machine),

adopting synthetic approach, according to the relevant knowledge provided by a large number of documents, refer to the data and learn the relevant specific knowledge, analyze and design the overall structure of the engraving machine and specific functional modules. The technical route of this article is shown as Figure 3.

(1) Refer to the literature, induce and summarize the shortages of existing PCB processing modes.

(2) Propose improvement plan for the existing PCB processing methods, such as chemical corrosion, environmental pollution, low efficiency, etc.

(3) According to the improvement scheme, find out the difficulties and key points in the scheme, and select the relevant technology to master.

(4) On the basis of mastering relevant technologies (such as PLC technology, CAD technology, communication interface technology, etc.), combine theory with practice, put forward solutions to improve the difficulties and key points.

(5) According to the scheme, carry out the hardware structure design of the engraving machine.

(6) According to the scheme, carry control system design of engraving machine.

(7) Build a prototype machine on the basis of item 5 and 6.

(8) The reliability and feasibility of the physical model are tested and continuously improved until the expected results are achieved.

(9) Summarize project experience and write papers.

### 3.3 The Scheme Design of the Motion Control System of the Engraving Machine

Compared with the main transmission system of common machine tools, the spindle system of a small and simple PCB engraving machine has light load and small volume, so the spindle system of an economical table engraving machine has simpler structure and easier operation. There are usually two kinds of spindle motion schemes: One is to use a special engraving head. When using this engraving head, it needs to be equipped with frequency conversion speed regulating device, which greatly increases the manufacturing cost. The other is to use DC motor to drive the spindle directly. The accuracy of this method is low, but the DC motor is cheap. For individuals and small and medium-sized users who do not require high accuracy and speed, the cost-effective scheme of DC motor driving the spindle is higher. The composition principle of the main motion scheme is shown as Figure 3.

### 3.4 Design of Feed Motion Scheme of Engraving Machine

According to the working requirement, the table engraving machine adopts open-loop CNC system. The design of the transmission part utilizes the working principle of the stepping motor to control (Pan Songguang, D., 2014) the screw drive. After the pulse signal sent by the CNC device is amplified by power, it drives the stepping motor to rotate a step angle and drives the screw nut pair to rotate to drive the axial displacement. The composition principle of feed motion scheme is shown as Figure 4.

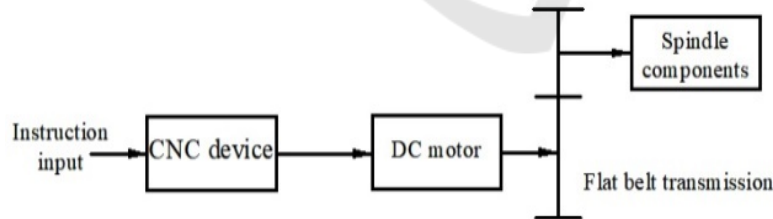

Figure 3. The composition principle of the main motion scheme.

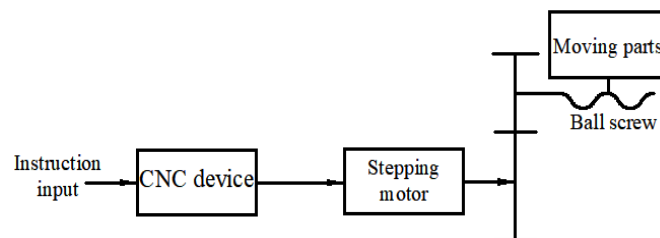

Figure 4. Composition principle of feed motion.

### 3.4.1 Selection of Motor

In small and medium servo systems controlled by open-loop, stepping motor and reducer transmission ratio can be used to calculate.

$$i = \frac{\alpha p}{360\delta_p} = \frac{1.5 \times 5}{360 \times 0.01} = 2 \quad (1)$$

The number of teeth of each transmission gear is respectively,  $Z_1=20$ ,  $Z_2=40$ , Modulum=2mm, Breadth of tooth  $b=20$ mm. Big gear is adjusted by staggered teeth of double cylindrical thin-section gear.

Calculation of total equivalent load moment of inertia on motor axis.

$$j_m = 0.617 \times 10^{-3} \text{ kg} \cdot \text{m}^2 \quad (2)$$

$$j_{z1} = \frac{\pi \times 7.8 \times 10^3 \times 0.04^4 \times 0.02}{32} \text{ kg} \cdot \text{m}^2 \quad (3)$$

$$j_{z2} = \frac{\pi \times 7.8 \times 10^3 \times 0.08^4 \times 0.02}{32} \text{ kg} \cdot \text{m}^2 \quad (4)$$

The total equivalent load moment of inertia can be obtained by converting the transmission inertia and the mass of the worktable to the motor axis.

$$j_d = j_{z1} + \frac{1}{i^2} j_{z2} + \left(\frac{p}{2\pi i}\right)^2 m \approx 2.12 \times 10^{-4} \text{ kg} \cdot \text{m}^2 \quad (5)$$

Therefore, the 75BF001 stepping motor is selected as the primary type.

### 3.4.2 Selection of Ball Screw

According to the dimension series of ball screw pairs (ISO/DIS3408-2.1991) and the standard table (Table 2) of GB/T 17587.2-1998, the 1204 ball screw is selected according to the actual design.

Table 2. Dimension series of ball screw pairs.

Nominal diameter series	mm	6, 8, 10, 12, 16, 20, 32, 50, 63, 100, 125, 200
Engineering lead series	mm	1, 2, 2.5, 3, 4, 5, 6, 8, 10, 12, 16, 20, 25
Engineering lead preferred series	mm	2.5, 5, 10, 20, 40

### 3.4.3 Coupling Original Selection

When the transmission ratio is  $i=1$ , the motor can be directly connected to the lead screw by coupling. If the worktable's pulse equivalent  $\delta = 0.01$  mm/pulse, According to the original selection screw specification M12\*4 in 2.4.2, the helical pitch is 4 mm.

Then based on transmission ratio formula

$$i = \frac{\theta_b \times L_0}{360 \times \delta_p}, \text{ we can obtain } i = \frac{0.9 \times 4}{360 \times 0.01} = 1$$

So the motor can be directly connected with the screw by coupling, and the clamping screw is selected to fix the micro rigid coupling.

## 4 DESIGN OF CONTROL SYSTEM OF ENGRAVING MACHINE

The design of control system consists of three main parts: control chip, spindle motor control scheme and stepping motor drive. The system realizes the communication between PC and engraving machine through parallel port of computer. The obtained processing object files are processed into G code by control software and the corresponding frequency and direction signals of processing characteristics are sent. The drive scheme of spindle motor adopts PWM pulse width modulation technology, which can control the speed of DC motor by changing the duty ratio of pulse sequence to change the output voltage (Zhang Xiao, D., 2013). Stepping motor drivers on three axes of engraving machine are all driven by stepping motor drivers with TB6560 as driving chip, which have the characteristics of high integration and high reliability, etc (Zhang Xiao, D., 2013). The control system software interface is shown as Figure5.

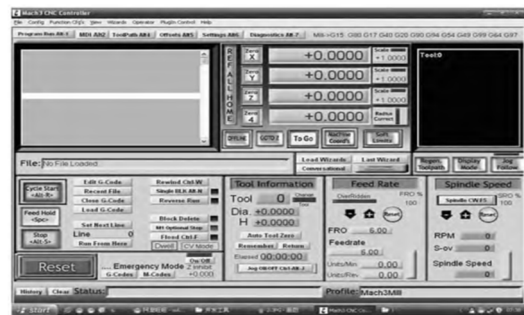

Figure 5. Control system software interface.

## 5 CONCLUSIONS

The engraving machine developed in this design is a kind of small-sized and simple printed circuit board engraving machine system. This system consists of physical layer, mechanical body, hardware layer, control circuit and software layer. The machine body adopts a gantry mobile layout with simple structure and high rigidity to ensure the reliability of machine tool; Control system software based on PC development realizes stepping motor driving carving feed. DC motor and PWM speed regulating circuit constitute the main motion system. It fully meets the manufacturing requirements of simple structure, stable operation, easy control and convenient maintenance.

## REFERENCES

- Chen Jianning, J., 2016. Popular Science (science education). In Popular Science (science education)'186+128, 5th edition of 2016. Scientific Popular (Science Education). Design of Economic Desktop Engraving Machine System.
- Fan Chaoyi, Fan Wei, J., 2018. In TEMPLATE' 310-314, Machine Tool and Hydraulic Pressure. Selection and calculation of stepping motor.
- Pan Songguang, D., 2014. Shandong University. Research on Machine Tool Product Design Based on UCD.
- Zhang Xiao, D., 2013. Nanjing Forestry Uni.

